

STILWELL STADIUM CANOPY

BID AND PERMIT SET | NOT ISSUED FOR CONSTRUCTION

OREGON TECH

3201 CAMPUS DR. KLAMATH FALLS, OR 97601



OREGON TECH
3201 CAMPUS DR.
KLAMATH FALLS, OR 97601

STILWELL STADIUM CANOPY



PROJECT NOTES	ABBREVIATIONS	PROJECT NARRATIVE	PROJECT TEAM	SHEET INDEX
<p>1. FIELD VERIFICATION: ALL EXISTING CONDITIONS MUST BE FIELD-VERIFIED. THE CONTRACTOR SHALL REPORT ANY DISCREPANCIES WITH THE DRAWINGS OR SPECIFICATIONS TO THE PROJECT TEAM.</p> <p>2. CONSTRUCTION RESPONSIBILITY: THE GENERAL CONTRACTOR IS RESPONSIBLE FOR ALL CONSTRUCTION METHODS, TECHNIQUES, SEQUENCING, SAFETY MEASURES, AND DEMOLITION ACTIVITIES.</p> <p>3. INSPECTION: BEFORE STARTING WORK, THE CONTRACTOR MUST INSPECT PRIOR WORK TO ENSURE IT IS PROPERLY ALIGNED AND LEVEL, ALLOWING SEAMLESS INTEGRATION WITH ADJACENT WORK.</p> <p>4. CODE COMPLIANCE: THE CONTRACTOR IS RESPONSIBLE FOR ENSURING ALL MATERIALS AND WORKMANSHIP COMPLY WITH APPLICABLE FEDERAL, STATE, AND LOCAL CODES.</p> <p>5. DOCUMENT VERIFICATION: THE CONTRACTOR MUST VERIFY THE ACCURACY OF ALL CONTRACT DOCUMENTS, FIELD CONDITIONS, AND DIMENSIONS BEFORE PROCEEDING. ANY QUESTIONS MUST BE CLARIFIED WITH THE PROJECT TEAM PRIOR TO THE COMMENCEMENT OF WORK.</p> <p>6. DIMENSIONS: DRAWINGS SHALL NOT BE SCALED. IF DIMENSIONS ARE MISSING OR UNCLEAR, THE CONTRACTOR MUST SEEK CLARIFICATION FROM THE PROJECT TEAM BEFORE PROCEEDING.</p> <p>7. PROTECTION & REPAIR: THE CONTRACTOR MUST PROTECT, PATCH, AND REPAIR ANY SURFACES DISTURBED DURING THE INSTALLATION OF MECHANICAL, ELECTRICAL, PLUMBING, OR OTHER WORK, ENSURING THEY MATCH EXISTING FINISHES.</p> <p>8. CUTTING & PATCHING: THE CONTRACTOR IS RESPONSIBLE FOR ALL CUTTING, PATCHING, AND DEMOLITION NECESSARY FOR MATERIAL AND EQUIPMENT INSTALLATION, INCLUDING RELATED REPAIRS.</p> <p>9. UNFORESEEN CONDITIONS: IF UNFORESEEN CONDITIONS ARE ENCOUNTERED, THE CONTRACTOR MUST NOTIFY THE PROJECT TEAM AND RESOLVE THE ISSUE BEFORE CONTINUING WORK.</p> <p>10. PERMITS: THE CONTRACTOR IS RESPONSIBLE FOR OBTAINING AND PAYING FOR ALL PROJECT-RELATED PERMITS, UNLESS OTHERWISE AGREED UPON.</p> <p>11. JOB SITE SAFETY: THE GENERAL CONTRACTOR IS SOLELY RESPONSIBLE FOR MAINTAINING JOB SITE SAFETY, INCLUDING THE PROTECTION OF PERSONNEL AND PROPERTY, IN COMPLIANCE WITH OSHA STANDARDS.</p> <p>12. DESIGN-BUILD COORDINATION: FOR DESIGN-BUILD ELEMENTS, THE CONTRACTOR IS RESPONSIBLE FOR DESIGN, PERMITS, AND COORDINATION WITH SUBCONTRACTORS. ALL DESIGN-BUILD ELEMENTS MUST BE COORDINATED WITH THE ARCHITECT/ENGINEER OF RECORD BEFORE FIELDWORK IS COMPLETED.</p> <p>13. BUILDING OPERATIONS: THE CONTRACTOR MUST AVOID DISRUPTING THE BUILDING'S NORMAL OPERATIONS AND FOLLOW RULES FOR SCHEDULING AND USING ELEVATORS, LOADING DOCKS, AND OTHER FACILITIES.</p>	<p>AB ANCHOR BOLT ACI AMERICAN CONCRETE INSTITUTE ACT ACOUSTICAL CEILING TILE ADJ ADJACENT AFF ABOVE FINISH FLOOR AISC AMERICAN INSTITUTE OF STEEL CONSTRUCTION APPX APPROXIMATE ARCH ARCHITECT ASCE AMERICAN SOCIETY OF CIVIL ENGINEERS ASTM AMERICAN SOCIETY FOR TESTING AND MATERIALS AWS AMERICAN WELDING SOCIETY BD BOARD BITUM BITUMINOUS BOT/B0 BOTTOM/BOTTOM OF BOD BASIS OF DESIGN CER CERAMIC CG CORNER GUARD CI CONTINUOUS INSULATION CJ CONTROL JOINT CJP COMPLETE JOINT PENETRATION CLR CLEAR CMU CONCRETE MASONRY UNIT CO CASED OPENING CONC CONCRETE CONN CONNECTION CONSTR CONSTRUCTION CONT CONTINUOUS CORR CORRIDOR CPT CARPET CT CERAMIC TILE DBA DEFORMED BAR ANCHOR DF DRINKING FOUNTAIN DIA, Ø DIAMETER DOOR DOOR DS DOWNSPOUT (E) EXISTING ELEC ELECTRICAL EQ EQUAL ETR EXISTING TO REMAIN EXT EXTERIOR FA FIRE ALARM FD FLOOR DRAIN FDN FOUNDATION FOF FACE OF FINISH FOS FACE OF STUDIOS FSD FIRE SEPARATION DISTANCE FTG FOOTING GA GAUGE GALV GALVANIZED GL GRID LINE GLB GLULAM BEAM GB GRAB BAR GND GROUND GSM GALVANIZED SHEET METAL GYP GYPSUM GYP BD GYPSUM WALL BOARD HB HOSE BIBB HC HOLLOW CORE HM HOLLOW METAL HORIZ HORIZONTAL HPC HIGH PERFORMANCE COATING HSS HOLLOW STRUCTURAL STEEL IBC INTERNATIONAL BUILDING CODE IN INCH INT INTERIOR K KIPS KSF KIPS PER SQUARE FOOT KSI KIPS PER SQUARE INCH LAM LAMINATE LB POUND LL LIVE LOAD LLH LONG LEG HORIZONTAL LLV LONG LEG VERTICAL LOC LOCATION LONG LONGITUDINAL LP LOW POINT LVF LOW VELOCITY FASTENER MAX MAXIMUM MBMA METAL BUILDING MANUFACTURERS ASSOCIATION ME MATCH EXISTING MECH MECHANICAL MFR MANUFACTURER MIN MINIMUM MISC MISCELLANEOUS MTD MOUNTED MULL MULLION (N) NEW NIC NOT IN CONTRACT NOM NOMINAL NTS NOT TO SCALE</p>	<p>PROJECT SCOPE: THIS PROJECT CONSISTS OF THE CONSTRUCTION OF A NEW CANOPY STRUCTURE OVER THE EXISTING BLEACHERS AT THE OREGON TECH SOFTBALL FIELD, ALONG WITH SITE IMPROVEMENTS TO ENHANCE THE OVERALL SPECTATOR EXPERIENCE. THE CANOPY DESIGN IS INSPIRED BY THE OREGON TECH STUDENT'S CONCEPT DESIGN.</p> <p>DESIGN BUILD SCOPE GENERAL CONTRACTOR AND SUBCONTRACTORS TO REVIEW CONSTRUCTION DOCUMENTS AND PROVIDE CODE REQUIRED MEP DESIGN IN COORDINATION WITH THE ARCHITECTURE PLANS. FURTHER MODIFICATION MAY BE REQUIRED.</p> <p>LIGHTNING PROTECTION: 1. INSTALL LIGHTNING PROTECTION AND GROUNDING DEVICES</p> <p>ALTERNATES BELOW ARE ADDITIVE ALTERNATES THAT ARE PROVIDED AS AN OPTION TO THE BASE BID AND SHALL BE PRICED SEPARATELY.</p> <p>ALTERNATE 1: PARKING 1. BASE BID: EXISTING CONDITION ALONG COLLEGE WAY TO REMAIN AS-IS 2. ALTERNATE: ADDITION OF ASPHALT PAVED PARKING STALLS, ECCO-BLOCK RETAINING WALL, STORM LINE RELOCATION, AND REPAIR TO IMPACTED LANDSCAPE AREAS</p> <p>ALTERNATE 2: CANOPY LIGHTING 1. BASE BID: NO LIGHTING UNDER CANOPY ROOF 2. ALTERNATE: PROVIDE LIGHT FIXTURES AND ALL ELECTRICAL SCOPE</p> <p>ALTERNATE 3: CANOPY ROOF DRAINAGE 1. BASE BID: NO CANOPY ROOF DRAINAGE SYSTEM 2. ALTERNATE: PROVIDE GUTTERS, DOWNSPOUTS, AND STORM PIPING</p> <p>ALTERNATE 4: FIELD APPLIED PAINT 1. BASE BID: STRUCTURAL STEEL TO BE SHOP PRIMED W/ FIELD TOUCH UP WHERE REQUIRED. COLOR GREY 2. ALTERNATE: FIELD PAINT STRUCTURAL STEEL FRAMING</p> <p>ALTERNATE 5: LIGHTNING PROTECTION 1. BASE BID: NO LIGHTNING PROTECTION ON CANOPY ROOF 2. ALTERNATE: PROVIDE LIGHTNING PROTECTION AS A DELEGATED DESIGN. PROTECTION SHOWN IN PLANS IS FOR ESTIMATING PURPOSES ONLY</p> <p>ALTERNATE 6: BIRD NETTING 1. BASE BID: NO BIRD NETTING UNDER CANOPY 2. ALTERNATE: PROVIDE BIRD NETTING AND SPIKES ATTACHED TO UNDERSIDE OF CANOPY</p>	<p>OWNER: CONTACT: <u>THOM DARRAH</u> OREGON TECH T 503.885.1661</p> <p>CIVIL ENGINEERING: ENGINEER OF RECORD: <u>ZACH STOKES, PE</u> CONTACT: <u>MALIA WATERS</u> ZCS, INC. T 541.884.7421</p> <p>ARCHITECTURE: ARCHITECT OF RECORD: <u>MATTHEW CRAWFORD, AIA</u> CONTACT: <u>LARRY SHIRTS</u> ZCS, INC. T 503.659.2205</p> <p>STRUCTURAL ENGINEERING: ENGINEER OF RECORD: <u>MATT SMITH, PE, SE</u> CONTACT: <u>KYLE MULLEN</u> ZCS, INC. T 503.659.2205</p> <p>ELECTRICAL ENGINEERING: CONTACT: <u>TYLER THOMPSON</u> ARCSINE ENGINEERING T 541.842.4188</p> <p>VICINITY MAP PROJECT LOCATION: 3201 CAMPUS DR. KLAMATH FALLS, OR 97601</p> <p>AERIAL PHOTO HATCH INDICATES AREA OF WORK</p>	<p>-GENERAL- G0.00 COVER SHEET</p> <p>-CIVIL- C0.01 CIVIL NOTES AND SPECIFICATIONS C0.30 TOPOGRAPHIC SURVEY C1.00 SITE DEMOLITION PLAN C2.00 OVERALL SITE PLAN C2.01 PARKING IMPROVEMENTS C2.02 BLEACHER CANOPY IMPROVEMENTS C3.00 CIVIL DETAILS C3.01 CIVIL DETAILS C4.00 AGENCY STANDARD DETAILS</p> <p>-ARCHITECTURAL- A0.10 ASSEMBLIES & SCHEDULES A1.00 FLOOR & DIMENSIONING PLANS A2.00 ROOF & REFLECTED CEILING PLANS A3.00 EXTERIOR ELEVATIONS A4.00 SECTIONS A5.00 BIRDS-EYE VIEW A8.00 EXTERIOR DETAILS AS.10 ARCHITECTURAL SPECIFICATIONS</p> <p>-ELECTRICAL- E1.00 ONE-LINE LOAD SUMMARY, PANELS & GENERAL NOTES</p> <p>-STRUCTURAL- S0.10 STRUCTURAL GENERAL NOTES S0.20 SPECIAL INSPECTIONS AND TESTING S0.30 SPECIAL INSPECTIONS AND TESTING S1.10 FOUNDATION AND ROOF FRAMING PLAN S2.10 FRAME ELEVATION S3.10 STRUCT. DETAILS S3.20 STRUCT. DETAILS</p>

SYMBOL LEGEND

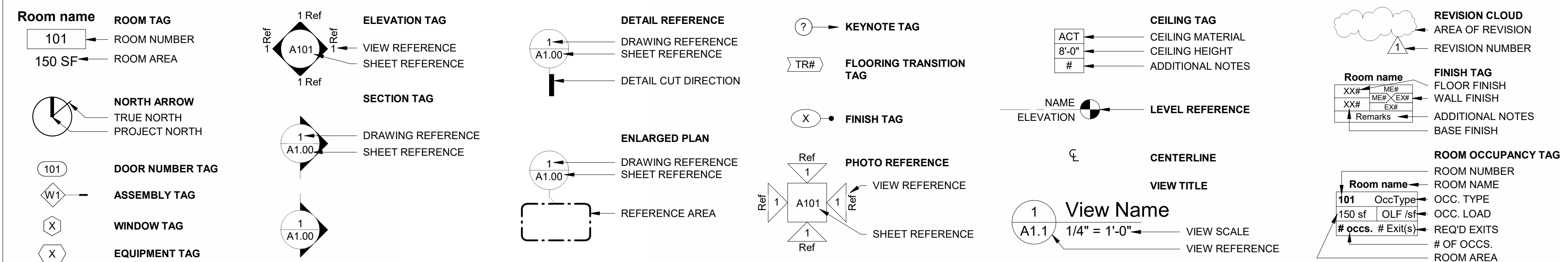

ONE INCH EQUALS FULL SCALE 3/9/2026 3:16:20 PM

REGISTERED ARCHITECT
Matthew J. Crawford
OREGON CITY, OR 97046
STATE OF OREGON

DATE:	Description

PROJECT NO. K-6428-25
DRAWN: JMH
CHECKED: MJC
DATE: 03-11-2026

COVER SHEET

GO.00

BID AND PERMIT SET | NOT ISSUED FOR CONSTRUCTION

ABBREVIATIONS

Table of abbreviations including AD (AREA DRAIN), APWA (AMERICAN PUBLIC WORKS ASSOCIATION), ASTM (AMERICAN STANDARD TEST METHOD), AWWA (AMERICAN WATER WORKS ASSOCIATION), BMP (BEST MANAGEMENT PRACTICE), BB (BUBBLE UP STRUCTURE), CO (CLEANOUT RISER), DEQ (DEPARTMENT OF ENVIRONMENTAL QUALITY), DI (DITCH INLET), (e) (EXISTING), EPA (ENVIRONMENTAL PROTECTION AGENCY), ESC (EROSION AND SEDIMENT CONTROL), FG (FINISHED GRADE), GC (GENERAL CONTRACTOR), HDPE (HIGH-DENSITY POLETHYLENE), IE (INVERT ELEVATION), LF (LINEAL FEET), MH (MANHOLE), MEP (MECHANICAL, ELECTRICAL, & PLUMBING), MUTCD (MANUAL ON UNIFORM TRAFFIC CONTROL DEVICES), MAX (MAXIMUM), MIN (MINIMUM), NAVD (NORTH AMERICAN VERTICAL DATUM), (N) (NEW), ODOT (OREGON DEPARTMENT OF TRANSPORTATION), OT (OREGON INSTITUTE OF TECHNOLOGY), OSSC (OREGON STRUCTURAL SPECIALTY CODE), OPSC (OREGON PLUMBING SPECIALTY CODE), OFOI (OWNER FURNISHED, OWNER INSTALLED), PVC (POLYVINYL CHLORIDE), ROW (RIGHT-OF-WAY), SD (STORM DRAIN), SS (SANITARY SEWER), TOC (TIME OF CONSTRUCTION), TYP (TYPICAL), UNO (UNLESS NOTED OTHERWISE)

GENERAL CIVIL CONSTRUCTION NOTES:

- 1. ALL WORK AND MATERIALS SHALL CONFORM TO THE 2024 OREGON STANDARD SPECIFICATIONS FOR CONSTRUCTION, CURRENT OREGON PLUMBING SPECIALTY CODE, AND ALL APPLICABLE STATE, CITY, AND COUNTY REGULATIONS AND STANDARDS. CONTACT ENGINEER FOR DIRECTIVE IN THE EVENT OF CONFLICTING STANDARDS.
2. THE GENERAL CONTRACTOR AND ALL THEIR AFFILIATES SHALL VERIFY ALL DIMENSIONS, ELEVATIONS, AND LOCATIONS PRIOR TO CONSTRUCTION. IMMEDIATELY NOTIFY ENGINEER OF ANY DISCREPANCIES.
3. ALL CONSTRUCTION STAKING, GRADE SURVEYING, AND HORIZONTAL LAYOUT SHALL BE THE RESPONSIBILITY OF THE CONTRACTOR AND SHALL BE PERFORMED BY A PROFESSIONAL LAND SURVEYOR LICENSED IN THE STATE OF OREGON; COORDINATE WITH ENGINEER PRIOR TO CONSTRUCTION.
4. ALL EXISTING UTILITIES IDENTIFIED IN THIS PLAN SET ARE NOT INTENDED TO BE EXACT OR COMPLETE. IT SHALL BE THE RESPONSIBILITY OF THE CONTRACTOR TO IDENTIFY ALL UTILITIES AND PROTECT AS REQUIRED DURING THE COURSE OF CONSTRUCTION. CALL THE "OREGON UTILITY NOTIFICATION CENTER" AT 1-800-332-2344 TO LOCATE EXISTING UTILITIES, 48 HOURS BEFORE DIGGING.
5. CONTRACTOR SHALL COORDINATE UTILITY SHUTOFF(S) WITH OWNER AND UTILITY PROVIDER 48 HOURS MINIMUM PRIOR TO CONSTRUCTION TO ENSURE MINIMAL SERVICE DISRUPTION DURING OPERATION HOURS.
6. CONTRACTOR SHALL NOTIFY ALL APPLICABLE REGULATORY AGENCIES AND UTILITY COMPANIES 48 HOURS PRIOR TO BEGINNING WORK.
7. ALL EXCAVATION, TRENCH BACK FILL, PARKING LOT/ROAD SUB-GRADE, FLAT WORK SUB-GRADE, COMPACTION REQUIREMENTS, ETC. SHALL BE AS NOTED IN THE SITE PREPARATION NOTES.
8. ALL BASE ROCK PLACED UNDER PAVEMENT AND IN UTILITY TRENCHES SHALL CONFORM TO THE 2024 OREGON STANDARD SPECIFICATIONS FOR CONSTRUCTION.
9. ALL ASPHALT CONCRETE AND PORTLAND CEMENT CONCRETE PAVEMENT AND ITS PLACEMENT SHALL CONFORM TO THE 2024 OREGON STANDARD SPECIFICATIONS FOR CONSTRUCTION.
10. CONTRACTOR SHALL OBTAIN ALL APPLICABLE PERMITS PRIOR TO COMMENCEMENT OF ANY CONSTRUCTION ACTIVITIES. COORDINATE WITH ENGINEER PRIOR TO CONSTRUCTION TO IDENTIFY PERMIT REQUIREMENTS.
11. ALL TEMPORARY PROTECTION AND DIRECTION OF TRAFFIC SHALL BE BY THE CONTRACTOR AND CONFORM WITH BOTH THE MANUAL ON UNIFORM TRAFFIC CONTROL DEVICES AND THE ODOT MANUAL ON SHORT TERM TRAFFIC CONTROL (AS APPLICABLE).
12. CONTRACTOR SHALL COORDINATE VEHICULAR AND PEDESTRIAN ACCESS REQUIREMENTS WITH OWNER PRIOR TO CONSTRUCTION.
13. PROVIDE SUBMITTALS TO ENGINEER FOR REVIEW AND APPROVAL PRIOR TO ORDERING MATERIALS. CONTRACTOR MAY ELECT TO SUBMIT SUBSTITUTION REQUESTS FOR EQUIVALENT PRODUCTS. ENGINEER WILL REVIEW AND APPROVE ON A CASE BY CASE BASIS.
14. CONTRACTOR SHALL PROVIDE ENGINEER WITH SHOP DRAWING SUBMITTALS ON ALL PERMANENTLY INSTALLED MANUFACTURED ITEMS.
15. CONTRACTOR SHALL FURNISH AND INSTALL ALL SPECIFIED MATERIALS UNLESS NOTED OTHERWISE.
16. SAND SEAL AND TACK ALL CUT ASPHALT EDGES WHEN PLACING NEW ASPHALT ADJACENT TO EXISTING ASPHALT.
17. TRANSITION BETWEEN NEW AND EXISTING ASPHALT/CONCRETE/CURB SHALL BE FLUSH AND FREE FROM ABRUPT CHANGES IN HEIGHT.
18. CONSTRUCT PAVING TO GRADES, ELEVATIONS, AND ALIGNMENTS SHOWN ON PLAN.
19. PREPARATION OF ALL LANDSCAPED AREAS SHALL BE AS NOTED IN THE LANDSCAPE NOTES.
20. CONTRACTOR SHALL RESTORE BACK TO ORIGINAL CONDITION PRIOR TO CONTRACT COMPLETION. ALL DISTURBED SURFACES IMPACTED DURING CONSTRUCTION. THIS INCLUDES, BUT IS NOT LIMITED TO, CONSTRUCTION ACCESS, SIDEWALKS, CURBS, ASPHALT, LAWN AND LANDSCAPE AREAS, ETC. DISTURBED AREAS TO BE GRADED SMOOTH AND ADEQUATELY SLOPED TO DRAIN. AREA SHALL BE CLEAN AND FINISH GRADED BEFORE FINAL DEMOBILIZATION. COORDINATE WITH ENGINEER AND OWNER AT THE TIME OF PROJECT CONSTRUCTION COMPLETION.
21. SEE PLAN SET AND PROJECT SPECIFICATIONS FOR ADDITIONAL INFORMATION.

EROSION CONTROL NOTE:

THIS EROSION AND SEDIMENT CONTROL PLAN MUST BE IMPLEMENTED PRIOR TO COMMENCEMENT OF CONSTRUCTION ACTIVITIES. THE INFORMATION CONTAINED WITHIN THIS PLAN SET SHALL BE CONSIDERED A MINIMUM AND SHALL BE MODIFIED AS REQUIRED BY THE CONTRACTOR AND CITY OF KLAMATH FALLS INSPECTOR, TO CONTAIN ALL SEDIMENT ON SITE. SPECIAL ATTENTION SHALL BE TAKEN AT ALL EXISTING STORM DRAIN CATCH BASINS AND STORM DRAIN CHANNELS AS TO ELIMINATE ANY SEDIMENT TRANSFER INTO THE PUBLIC STORM DRAIN SYSTEM.

ALL CONSTRUCTION SHALL BE MAINTAINED WITHIN THE DEVELOPMENT LIMITS SHOWN. REFER TO PROJECT CONSTRUCTION DOCUMENTS FOR ADDITIONAL INFORMATION.

SITE PREPARATION NOTES:

CLEARING AND GRUBBING

- 1. REFER TO STRUCTURAL (FOUNDATION) PLANS FOR SPECIFIC SOIL EXCAVATION AND BACKFILL REQUIREMENTS WITHIN CANOPY FOOTPRINT.
2. ALL AREAS BELOW ROADWAYS, PARKING AREAS, AND WALKWAYS SHALL BE CLEARED AND GRUBBED OF ALL PAVEMENT, FOREIGN MATTER, DEBRIS, ORGANIC AND DISTURBED MATERIAL, (U.N.O.). STRIPPING DEPTHS WILL VARY DEPENDING ON LOCATION AND PAVEMENT SECTION REQUIREMENTS. ALL EXPOSED MATERIAL SHALL BE MOISTURE CONDITIONED TO WITHIN 2% OF OPTIMUM PRIOR TO PLACEMENT OF FILL MATERIAL DESCRIBED BELOW.
3. ALL CLEARED AND GRUBBED MATERIAL NOT UTILIZED FOR THE PROJECT SHALL BE REMOVED FROM THE CONSTRUCTION SITE. CONTRACTOR SHALL COORDINATE APPROVED DISPOSAL LOCATION, IF OVER 50 CUBIC YARDS OF MATERIAL ARE TO BE HAULED TO ANY SITE WITHIN CITY LIMITS A SITE CONSTRUCTION PERMIT WILL BE REQUIRED FOR THE DISPOSAL SITE. COORDINATE WITH CITY INSPECTOR AT TIME OF CONSTRUCTION.
4. ALL AREAS WITH ABANDONED UTILITY LINES, STORM DRAINS, UNDERGROUND TANKS, ETC. WHICH PROVIDE VOID SPACE BENEATH THE SURFACE SHALL BE LOCATED AND REMOVED PRIOR TO GRADING ACTIVITIES.
5. ALL HOLES, DEPRESSIONS, AND UNDISTURBED NATIVE MATERIAL SHALL BE CLEARED OF ALL LOOSE AND ORGANIC MATERIAL PRIOR TO BACKFILLING WITH APPROVED STRUCTURAL FILL.
6. AFTER CLEARING THE ABOVE MENTIONED AREAS, ALL EXPOSED SUB-GRADE SHALL BE PROOF ROLLED WITH A LOADED DUMP TRUCK OR HEAVY NON-VIBRATORY ROLLER. SOILS SHALL BE REMOVED AND RECOMPACTED OR REPLACED WITH APPROVED IMPORTED STRUCTURAL FILL IF THEY DO NOT DEMONSTRATE A FIRM, UNYIELDING CONDITION. ENGINEER OF RECORD SHALL APPROVE SUB-GRADE SURFACE PRIOR TO STRUCTURAL FILL IMPORT EXPLAINED BELOW.
7. THE SITE SHALL BE CLEARED AND GRUBBED OF ALL ORGANIC AND/OR EXPANSIVE MATERIAL PRIOR TO STRUCTURAL FILL IMPORT.
8. STRUCTURAL FILL PLACEMENT AND COMPACTION
APPROVED STRUCTURAL FILL SHALL BE IMPORTED AND PLACED BENEATH AREAS RECEIVING ASPHALT.
9. ALL VEHICULAR TRAFFIC AREAS RECEIVING ASPHALT SHALL BE UNDERLAIN WITH "ACF" "WSF-200" WOVEN GEOTEXTILE FABRIC APPLIED DIRECTLY OVER THE SUB-GRADE DESCRIBED ABOVE.
10. STRUCTURAL FILL MATERIALS SHALL BE APPROVED BY THE ENGINEER OF RECORD PRIOR TO IMPORTING. ALL FILL SHALL BE FREE OF ORGANIC AND EXPANSIVE CLAY MATERIAL. ALL BASE ROCK SHALL CONFORM TO THE SPECIFICATIONS IDENTIFIED IN THE PLAN SET.
11. STRUCTURAL FILL PLACEMENT LIFTS TO BE DETERMINED BY THE ENGINEER OF RECORD BASED ON MATERIAL PROPERTIES AND TYPE OF COMPACTION EQUIPMENT USED. BASE ROCK PLACEMENT LIFTS SHALL NOT EXCEED 8". EACH LIFT SHALL BE NEARLY EQUAL IN THICKNESS AND COMPACTION TO A MINIMUM OF 98% OF ASTM D698. FILLS SHALL BE PLACED AT OR SLIGHTLY ABOVE THEIR OPTIMUM MOISTURE CONTENT.
12. IN ADDITION TO THE NOTES ABOVE, ALL SITE PREPARATION AND SUBSURFACE WORK SHALL CONFORM TO THE PROJECT GEOTECHNICAL INVESTIGATION REPORT AS PREPARED BY "MARQUESS & ASSOCIATES INC.", DATED 05/04/2018.

UTILITY INSTALLATION NOTES:

- 1. ALL UTILITIES SHALL HAVE A MINIMUM COVER AS IDENTIFIED IN THE PLAN SET OR AS OTHERWISE SPECIFIED BY THE RESPECTIVE UTILITY COMPANY.
2. ALL SERVICES SHALL BE ADEQUATELY MARKED AS TO IDENTIFY THE SIZE, TYPE, AND DEPTH OF THE SERVICE. CONTRACTOR TO PROVIDE LOCATE WIRE/TAPE SPECIFIED IN PLANS AND AS REQUIRED BY APPLICABLE AGENCIES.
3. ALL SERVICE CONDUIT AND SLEEVES SHALL BE PLUGGED AS REQUIRED TO ENSURE THAT NO FOREIGN MATERIALS ENTER THE LINE.
4. GAS, POWER, TELEPHONE, CABLE, AND FIBER OPTIC LINES SHALL BE INSTALLED BASED ON THE PLANS AND SPECIFICATIONS PROVIDED BY THE APPLICABLE UTILITY COMPANIES. APPROXIMATE UTILITY LOCATIONS HAVE BEEN PROVIDED ON THIS PLAN SET AS A REFERENCE. CONTRACTOR SHALL COORDINATE TRENCH EXCAVATIONS, CONDUIT INSTALLATIONS, BEDDING, BACKFILLING, AND INSPECTION REQUIREMENTS WITH THE APPROPRIATE UTILITY REPRESENTATIVES.
5. CONTRACTOR SHALL PROVIDE THE ENGINEER WITH AN AS-BUILT DRAWING OF ALL UTILITY SERVICE INSTALLATIONS INCLUDING THE SERVICE SIZE, TYPE, DEPTH OF MAIN, TYPE OF CONNECTION AT MAIN, INSTALLATION DATE, LOCATION, AND SKETCH (AS APPLICABLE).
6. REFER TO MECHANICAL/ELECTRICAL/PLUMBING PLANS FOR ALL PIPING REQUIREMENTS WITHIN FIVE (5) OF STRUCTURES.
7. EXISTING UNDERGROUND UTILITIES ILLUSTRATED IN THESE PLANS ARE APPROXIMATED BASED ON MAPS OBTAINED FROM THE OREGON TECH RECORD DRAWINGS, OR HAVE BEEN LOCATED BY A UTILITY LOCATE COMPANY. LAYOUT INDICATED IS NOT TO BE RELIED ON AS BEING EXACT OR COMPLETE. ALL LINES WITHIN PROJECTED WORK ZONE SHALL BE FIELD VERIFIED AS REQUIRED PRIOR TO CONSTRUCTION.
8. CONSTRUCT UTILITY STRUCTURES AND PIPING TO GRADES, ELEVATIONS, AND ALIGNMENTS SHOWN ON PLAN.
9. STORM COLLECTION SYSTEM IS DESIGNED FOR WATER TIGHT COMPONENTS.
10. ALL STORM PIPE SHALL BE 'PVC' ASTM D 3034 - SDR 35, 'PERF' ASTM D 3034 WITH 3-WAY DIRECTIONAL PERFORATIONS, OR 'HDPE' "N-12 WT IB" CONFORMING TO ASTM F 2306 AND 2648. PVC AND PERFORATED PVC PIPES SHALL BE FITTED WITH SOLVENT-CEMENTED JOINTS, HDPE PIPES SHALL BE FITTED WITH ELASTOMERIC GASKETS CONFORMING TO ASTM F 477.
11. ALL LATERAL CONNECTIONS TO STORM PIPES SHALL BE MADE USING PREFABRICATED 'WYE' OR 'ADS' 'INSERTA-WYE' FITTINGS.
12. ALL STORM COLLECTION SYSTEM CONNECTIONS AND COMPONENTS SHALL CONFORM TO PIPE MANUFACTURER REQUIREMENTS. CONTRACTOR TO COORDINATE FINAL STORM SYSTEM LAYOUT WITH ENGINEER AND STORM SYSTEM SUPPLIER PRIOR AT TIME OF CONSTRUCTION.
13. ALL CATCH BASINS AND AREA DRAIN INLETS SHALL BE AS IDENTIFIED ON PLAN SET. ALL STORM SYSTEM INLETS SHALL BE PROVIDED WITH A MINIMUM 24" SETTLEMENT SUMP BELOW THE LOWEST PIPE INVERT (UNLESS NOTED OTHERWISE) AND SHALL BE EQUIPPED WITH A POLLUTION CONTROL HOOD AND TRAP SYSTEM.
14. ALL UNDERGROUND PIPING, CONDUIT AND OTHER UTILITIES SHALL BE INSTALLED PER ZCS DETAILS CONTAINED IN THIS PLAN SET AND AS NOTED ON PLANS (OR AS OTHERWISE SPECIFIED BY PIPE MANUFACTURER). NOTIFY ENGINEER IN EVENT OF DISCREPANCIES.

CONCRETE CONSTRUCTION NOTES:

THE FOLLOWING NOTES APPLY TO ALL PROJECT CONCRETE. CONTACT THE ENGINEER OF RECORD FOR CLARIFICATION AS REQUIRED.

GENERAL NOTES

- 1. ALL CONCRETE SHALL HAVE A MINIMUM COMPRESSIVE STRENGTH AS LISTED BELOW, WHEN TESTED IN ACCORDANCE WITH ASTM C39/C39M AT 28 DAYS, UNLESS NOTED OTHERWISE IN THIS PLAN SET. PROVIDE STANDARD CONCRETE TESTING PUCKS FROM CONCRETE SUPPLIER.
- FLATWORK AND CURBS: f'c = 3,500-psi
2. ALL CONCRETE SHALL HAVE 6% (±1%) AIR ENTRAINMENT.
3. ALL CONCRETE SHALL HAVE 4" (±1") SLUMP, UNLESS NOTED OTHERWISE.
4. PERFORM WORK IN ACCORDANCE WITH ACI 301 AND ACI 318. FOLLOW RECOMMENDATIONS OF ACI 305R WHEN CONCRETING DURING HOT WEATHER AND ACI 306R WHEN CONCRETING DURING COLD WEATHER. PLACE CONCRETE IN ACCORDANCE WITH ACI 304R. ENSURE REINFORCEMENT, INSERTS, EMBEDDED PARTS, FORMED JOINTS ARE NOT DISTURBED DURING CONCRETE PLACEMENT. PLACE CONCRETE CONTINUOUSLY OVER THE FULL WIDTH OF THE PANEL AND BETWEEN PREDETERMINED CONSTRUCTION JOINTS.
5. ALL CONCRETE SHALL BE PLACED OVER 4" MINIMUM LAYER (UNLESS NOTED OTHERWISE) OF APPROVED 3/4" MINUS ODOT SPEC CRUSHED ROCK COMPACTED TO 95% ASTM D698/ASHTO T-99 OVER APPROVED COMPACTED (ASTM D698) STRUCTURAL FILL AS REQUIRED FOR GRADE OVER FIRM, UNDISTURBED, NON-ORGANIC NATIVE MATERIAL. SEE SITE PREPARATION NOTES ON THIS SHEET FOR ADDITIONAL REQUIREMENTS AND INFORMATION.
6. PLACE AND SECURE FORMS TO CORRECT LOCATION, DIMENSION, PROFILE, AND GRADIENT. ASSEMBLE FORMWORK TO PERMIT EASY STRIPPING AND DISMANTLING WITHOUT DAMAGING CONCRETE.
7. MAXIMUM VARIATION OF SURFACE FLATNESS SHALL NOT EXCEED 1/4 INCH IN 10 FT AND MAXIMUM VARIATION FROM TRUE POSITION SHALL NOT EXCEED 1/4 INCH.
8. IMMEDIATELY AFTER PLACEMENT, PROTECT PAVEMENT FROM PREMATURE DRYING, EXCESSIVE HOT OR COLD TEMPERATURES, AND MECHANICAL INJURY. DO NOT PERMIT PEDESTRIAN TRAFFIC OVER PAVEMENT FOR 7 DAYS MINIMUM AFTER FINISHING.
9. CONSTRUCTION AND ISOLATION JOINTS
9. SIDEWALKS:
- PROVIDE CONTRACTION JOINTS AT 'X'-FT' O.C.
- PROVIDE 3/8" ISOLATION JOINTS (HOLD JOINT FILLER DOWN 1/2" TYPICAL) AT 3X 'X'-FT' O.C.
- REFER TO DIMENSIONING PLAN FOR 'X' VALUES, VARIES BY LOCATION.
18. PLACE JOINT FILLER VERTICAL IN POSITION, IN STRAIGHT LINES. SECURE TO FORMWORK DURING CONCRETE PLACEMENT. HOLD TOP OF PRE-MOLDED JOINT FILLER DOWN 1/2" AND SEAL UPPER 3/8" WITH GRAY SONOLASTIC SL-2 FLEXIBLE JOINT COMPOUND (OR APPROVED EQUAL).
19. ALL JOINTS SHALL BE GREEN SAWN A MIN OF 1/8" WIDE x 1 1/4" DEEP AS SOON AS LABOR AND EQUIPMENT CAN ACCESS POUR. IN NO CIRCUMSTANCES SHALL THIS OCCUR MORE THAN 24 HOURS AFTER POUR IS COMPLETE.
20. NON-CONTINUOUS JOINTS SHALL BE CORE DRILLED WITH A 4" DIAMOND BIT DRILL AND BACKFILLED WITH CONCRETE OF THE SAME MIX DESIGN OF THE CONCRETE PAVEMENT. CORE DRILLING TO TAKE PLACE IN GREEN CONCRETE AT THE TIME OF INITIAL SAWING. BACKFILL AFTER 24 HOURS CURE TIME (MIN).

FINISHING

- 21. FINISH CONCRETE AS FOLLOWS:
A. SIDEWALK PAVING: LIGHT BROOM, TEXTURE PERPENDICULAR TO DIRECTION OF TRAVEL WITH TROWELED AND RADIUS EDGE 1/2 INCH RADIUS.
B. PLACE CURING COMPOUND ON EXPOSED CONCRETE SURFACES IMMEDIATELY AFTER FINISHING. APPLY IN ACCORDANCE WITH MANUFACTURER INSTRUCTIONS.

PAVEMENT MARKING AND TRAFFIC SIGNAGE NOTES:

- 1. ALL STANDARD ON-SITE PAINTED STRIPING SHALL BE FAST DRYING "TRAFFIC LINE PAINT" CONFORMING TO THE 2024 STATE OF OREGON APWA / ODOT STANDARD SPECIFICATIONS FOR CONSTRUCTION. ALL STRIPING SHALL BE APPLIED TWICE.
2. ALL 'HIGH SKID' ACCESSIBLE STRIPING, CROSSWALKS, AND LEGENDS SHALL BE FUSED THERMOPLASTIC FILM WITH INTERMIXED REFLECTIVE ELEMENTS AND FACTORY INSTALLED CRUSHED GLASS OR AGGREGATE ON THE SURFACE, CONFORMING TO THE 2024 STATE OF OREGON APWA / ODOT STANDARD SPECIFICATIONS FOR CONSTRUCTION.
3. ALL STRIPING, SIGNS, LETTERS, AND ARROWS SHALL CONFORM TO THE CURRENT EDITION OF THE MANUAL ON UNIFORM TRAFFIC CONTROL DEVICES FOR STREETS AND HIGHWAYS (MUTCD).
4. ALL ACCESSIBLE PARKING STRIPING AND SIGNAGE SHALL COMPLY WITH CURRENT ADA STANDARDS FOR ACCESSIBLE DESIGN.

SITE DEMOLITION AND PROTECTION NOTES:

- 1. CONTRACTOR SHALL FIELD VERIFY LIMITS OF ASPHALT/CONCRETE/ETC. DEMOLITION AND ADJUST AS REQUIRED.
2. PROVIDE SMOOTH VERTICAL SAWCUT AT ALL EXTERIOR LIMITS OF ASPHALT/CONCRETE/ETC. REMOVAL.
3. UPON MOBILIZATION, CONTRACTOR SHALL POT HOLE EXISTING BURIED UTILITIES AND STRUCTURES (AS INDICATED) TO VERIFY HORIZONTAL AND VERTICAL ALIGNMENT, SIZE, AND MATERIAL.
4. CONTRACTOR SHALL REPORT TO ENGINEER FOR DIRECTION IN EVENT OF DISCREPANCIES BETWEEN PLANS AND FIELD CONDITIONS.
5. CONTRACTOR SHALL STORE SALVAGED MATERIALS ON SITE (OR AT AN APPROVED OFF SITE LOCATION) FOR REUSE.
6. UNLESS NOTED OTHERWISE, ALL EXISTING STRUCTURES, HARDCAPE, AND UTILITIES/APPURTENANCES SHALL BE PROTECTED THROUGHOUT ALL PHASES OF CONSTRUCTION.
7. CONTRACTOR SHALL RECYCLE DEMOLISHED MATERIALS AT AN APPROVED OFF-SITE LOCATION.

Table with 4 columns: CONSTRUCTION ELEMENT, INSPECTOR, FREQUENCY, NOTES. Rows include Pavement Subgrade, Sidewalk Subgrade, Foundation Subgrade, Pavement Aggregate Base, Sidewalk Aggregate Base, Foundation Aggregate Base, Asphalt Pavement, Concrete Pavement, Sidewalk Concrete, and Trench Backfill.



OREGON TECH
3201 CAMPUS DR.
KLAMATH FALLS, OR 97601

STILWELL
STADIUM
CANOPY



Table with 2 columns: DESCRIPTION, DATE. Multiple empty rows for recording changes.

PROJECT NO: K-6428-25
DESIGNED: MEG, CMW
REVIEWED: MKW
DATE: 03-11-2026

CIVIL NOTES AND
SPECIFICATIONS

C0.01

ONE INCH EQUALS FULL SCALE

BID & PERMIT SET NOT ISSUED FOR CONSTRUCTION

DIVISION 01 - GENERAL REQUIREMENTS

**SECTION 015713
TEMPORARY EROSION AND SEDIMENT CONTROL**

PART 1 - GENERAL

1.1 SECTION INCLUDES

- A. Prevention of erosion due to construction activities.
- B. Prevention of sedimentation of waterways, open drainage ways, and storm and sanitary sewers due to construction activities.
- C. Restoration of areas eroded due to insufficient preventive measures.
- D. Compensation of Owner for fines levied by authorities having jurisdiction due to non-compliance by Contractor.

1.2 RELATED REQUIREMENTS

- A. Section 033000 - Cast-in-Place Concrete: Concrete for temporary and permanent erosion control structures indicated on drawings.
- B. Section 311000 - Site Clearing: Limits on clearing; disposition of vegetative clearing debris.
- C. Section 312200 - Grading: Temporary and permanent grade changes for erosion control.
- D. Section 321500 - Aggregate Surfacing: Temporary and permanent roadways.

1.3 PERFORMANCE REQUIREMENTS

- A. Comply with requirements of EPA (NPDES) for erosion and sedimentation control, as specified by the NPDES, for all phases, and in compliance with requirements of Construction General Permit (CGP), whether the project is required by law to comply or not.
- B. Best Management Practices Standard: FHWA FLP-94-005.
- C. Develop and follow an Erosion and Sedimentation Prevention Plan and submit periodic inspection reports.
- D. Do not begin clearing, grading, or other work involving disturbance of ground surface cover until applicable permits have been obtained; furnish all documentation required to obtain applicable permits.
 - 1. Owner will obtain permits and pay for securities required by authority having jurisdiction.
 - 2. Owner will withhold payment to Contractor equivalent to all fines resulting from non-compliance with applicable regulations.
- E. Timing: Put preventive measures in place as soon as possible after disturbance of surface cover and before precipitation occurs.
- F. Storm Water Runoff: Control increased storm water runoff due to disturbance of surface cover due to construction activities for this project.
 - 1. Prevent runoff into storm and sanitary sewer systems, including open drainage channels, in excess of actual capacity or amount allowed by authorities having jurisdiction, whichever is less.
 - 2. Anticipate runoff volume due to the most extreme short term and 24-hour rainfall events that might occur in 2 years.
- G. Erosion On Site: Minimize wind, water, and vehicular erosion of soil on project site due to construction activities for this project.
 - 1. Control movement of sediment and soil from temporary stockpiles of soil.
 - 2. Prevent development of ruts due to equipment and vehicular traffic.
 - 3. If erosion occurs due to non-compliance with these requirements, restore eroded areas at no cost to Owner.
- H. Erosion Off Site: Prevent erosion of soil and deposition of sediment on other properties caused by water leaving the project site due to construction activities for this project.
 - 1. Prevent windblown soil from leaving the project site.
 - 2. Prevent tracking of mud onto public roads outside site.
 - 3. Prevent mud and sediment from flowing onto sidewalks and pavements.
 - 4. If erosion occurs due to non-compliance with these requirements, restore eroded areas at no cost to Owner.
- I. Sedimentation of Waterways On Site: Prevent sedimentation of waterways on the project site, including rivers, streams, lakes, ponds, open drainage ways, and storm sewers.
 - 1. If sedimentation occurs, install or correct preventive measures immediately at no cost to Owner; remove deposited sediments; comply with requirements of authorities having jurisdiction.
 - 2. If sediment basins are used as temporary preventive measures, pump dry and remove deposited sediment after each storm.
- J. Sedimentation of Waterways Off Site: Prevent sedimentation of waterways off the project site, including rivers, streams, lakes, ponds, open drainage ways, and storm sewers.
 - 1. If sedimentation occurs, install or correct preventive measures immediately at no cost to Owner; remove deposited sediments; comply with requirements of authorities having jurisdiction.
- K. Open Water: Prevent standing water that could become stagnant.
- L. Maintenance: Maintain temporary preventive measures until permanent measures have been established.

1.4 SUBMITTALS

- A. See Section 013000 - Administrative Requirements, for submittal procedures.
- B. Certificate: Mill certificate for silt fence fabric attesting that fabric and factory seams comply with specified requirements, signed by legally authorized official of manufacturer; indicate actual minimum average roll values; identify fabric by roll identification numbers.
- C. Inspection Reports: Submit report of each inspection; identify each preventive measure, indicate condition, and specify maintenance or repair required and accomplished.
- D. Maintenance Instructions: Provide instructions covering inspection and maintenance for temporary measures that must remain after Substantial Completion.

PART 2 - PRODUCTS

2.1 MATERIALS

- A. Grass Seed For Temporary Cover: Select a species appropriate to climate, planting season, and intended purpose. If same area will later be planted with permanent vegetation, do not use species known to be excessively competitive or prone to volunteer in subsequent seasons.

- B. Silt Fence Fabric: Polypropylene geotextile resistant to common soil chemicals, mildew, and insects; non-biodegradable; in longest lengths possible; fabric including seams with the following minimum average roll lengths:
 - 1. Average Opening Size: 30 U.S. Std. Sieve, maximum, when tested in accordance with ASTM D4751.
 - 2. Permittivity: 0.05 sec⁻¹, minimum, when tested in accordance with ASTM D4491/D4491M.
 - 3. Ultraviolet Resistance: Retaining at least 70 percent of tensile strength, when tested in accordance with ASTM D4355/D4355M after 500 hours exposure.
 - 4. Tensile Strength: 100 pounds-force, minimum, in cross-machine direction; 124 pounds-force, minimum, in machine direction; when tested in accordance with ASTM D4632/D4632M.
 - 5. Elongation: 15 to 30 percent, when tested in accordance with ASTM D4632/D4632M.
 - 6. Tear Strength: 55 pounds-force, minimum, when tested in accordance with ASTM D4533/D4533M.
 - 7. Color: Manufacturer's standard, with embedment and fastener lines preprinted.
- C. Silt Fence Posts: One of the following, minimum 5 feet long:

PART 3 - EXECUTION

3.1 EXAMINATION

- A. Examine site and identify existing features that contribute to erosion resistance; maintain such existing features to greatest extent possible.

3.2 PREPARATION

- A. Schedule work so that soil surfaces are left exposed for the minimum amount of time.

3.3 SCOPE OF PREVENTIVE MEASURES

- A. In all cases, if permanent erosion resistant measures have been installed temporary preventive measures are not required.
- B. Construction Entrances: Traffic-bearing aggregate surface.
 - 1. Width: As required; 20 feet, minimum.
 - 2. Length: 25 feet, minimum.
 - 3. Provide at each construction entrance from public right-of-way.
 - 4. Where necessary to prevent tracking of mud onto right-of-way, provide wheel washing area out of direct traffic lane, with drain into sediment trap or basin.
- C. Linear Sediment Barriers: Made of silt fences.
 - 1. Provide linear sediment barriers:
 - a. Along downhill perimeter edge of disturbed areas, including soil stockpiles.
 - 2. Space sediment barriers with the following maximum slope length upslope from barrier:
 - a. Slope of Less Than 2 Percent: 100 feet.
 - b. Slope Between 2 and 5 Percent: 75 feet.
 - c. Slope Between 5 and 10 Percent: 50 feet.
 - d. Slope Between 10 and 20 Percent: 25 feet.
 - e. Slope Over 20 Percent: 15 feet.
- D. Storm Drain Curb Inlet Sediment Trap: Protect each curb inlet using one of the following measures:
 - 1. Filter fabric wrapped around hollow concrete blocks blocking entire inlet face area; use one piece of fabric wrapped at least 1-1/2 times around concrete blocks and secured to prevent dislodging; orient cores of blocks so runoff passes into inlet.
 - 2. Straw bale row blocking entire inlet face area; anchor into pavement.
- E. Storm Drain Drop Inlet Sediment Traps: As detailed on drawings.
- F. Temporary Splash Pads: Stone aggregate over filter fabric; size to suit application; provide at downspout outlets and storm water outlets.
- G. Soil Stockpiles: Protect using one of the following measures:
 - 1. Cover with polyethylene film, secured by placing soil on outer edges.
 - 2. Cover with mulch at least 4 inches thickness of pine needles, sawdust, bark, wood chips, or shredded leaves, or 6 inches of straw or hay.
- H. Mulching: Use only for areas that may be subjected to erosion for less than 6 months.
- I. Temporary Seeding: Use where temporary vegetated cover is required.

3.4 INSTALLATION

- A. Traffic-Bearing Aggregate Surface:
 - 1. Excavate minimum of 6 inches.
 - 2. Place geotextile fabric full width and length, with minimum 24 inch overlap at joints.
 - 3. Place and compact at least 8 inches of 2 inch diameter drain rock.
- B. Silt Fences:
 - 1. Store and handle fabric in accordance with ASTM D4873/D4873M.
 - 2. Where slope gradient is less than 3:1 or barriers will be in place less than 6 months, use nominal 16 inch high barriers with minimum 36 inch long posts spaced at 6 feet maximum, with fabric embedded at least 4 inches in ground.
 - 3. Where slope gradient is steeper than 3:1 or barriers will be in place over 6 months, use nominal 28 inch high barriers, minimum 48 inch long posts spaced at 6 feet maximum, with fabric embedded at least 6 inches in ground.
 - 4. Where slope gradient is steeper than 3:1 and vertical height of slope between barriers is more than 20 feet, use nominal 32 inch high barriers with woven wire reinforcement and steel posts spaced at 4 feet maximum, with fabric embedded at least 6 inches in ground.
 - 5. Install with top of fabric at nominal height and embedment as specified.
 - 6. Do not splice fabric width; minimize splices in fabric length; splice at post only, overlapping at least 18 inches, with extra post.

- 7. Wherever runoff will flow around end of barrier or over the top, provide temporary splash pad or other outlet protection; at such outlets in the run of the barrier, make barrier not more than 12 inches high with post spacing not more than 4 feet.
- C. Temporary Seeding:
 - 1. When hydraulic seeder is used, seedbed preparation is not required.
 - 2. When surface soil has been sealed by rainfall or consists of smooth undisturbed cut slopes, and conventional or manual seeding is to be used, prepare seedbed by scarifying sufficiently to allow seed to lodge and germinate.
 - 3. If temporary mulching was used on planting area but not removed, apply nitrogen fertilizer at 1 pound per 1000 sq ft.
 - 4. On soils of very low fertility, apply 10-10-10 fertilizer at rate of 12 to 16 pounds per 1000 sq ft.
 - 5. Incorporate fertilizer into soil before seeding.
 - 6. Apply seed uniformly; if using drill or cultipacker seeders place seed 1/2 to 1 inch deep.
 - 7. Irrigate as required to thoroughly wet soil to depth that will ensure germination, without causing runoff or erosion.
 - 8. Repeat irrigation as required until grass is established.

3.5 MAINTENANCE

- A. Inspect preventive measures weekly, within 24 hours after the end of any storm that produces 0.5 inches or more rainfall at the project site, and daily during prolonged rainfall.
- B. Repair deficiencies immediately.
- C. Silt Fences:
 - 1. Promptly replace fabric that deteriorates unless need for fence has passed.
 - 2. Remove silt deposits that exceed one-third of the height of the fence.
 - 3. Repair fences that are undercut by runoff or otherwise damaged, whether by runoff or other causes.
- D. Clean out temporary sediment control structures weekly and relocate soil on site.
- E. Place sediment in appropriate locations on site; do not remove from site.

3.6 CLEAN UP

- A. Remove temporary measures after permanent measures have been installed, unless permitted to remain by Engineer.
- B. Clean out temporary sediment control structures that are to remain as permanent measures.
- C. Where removal of temporary measures would leave exposed soil, shape surface to an acceptable grade and finish to match adjacent ground surfaces.

END OF SECTION 015713

ONE INCH EQUALS FULL SCALE



OREGON TECH
3201 CAMPUS DR.
KLAMATH FALLS, OR 97601

**STILWELL
STADIUM
CANOPY**

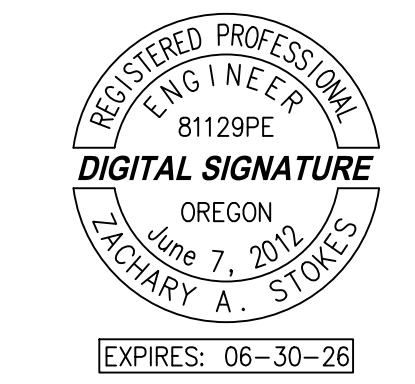

DESCRIPTION	DATE

PROJECT NO:	K-6428-25
DESIGNED:	MEG, CMW
REVIEWED:	MKW
DATE:	03-11-2026

**CIVIL GENERAL
REQUIREMENTS
SPECIFICATIONS**

C0.02

BID & PERMIT SET NOT ISSUED FOR CONSTRUCTION

DIVISION 31 - EARTHWORK
SECTION 311000
SITE CLEARING

PART 1 - GENERAL

1.1 Section Includes

- A. Clearing and grubbing.
- B. Repair and restoration.
- C. Debris removal.

1.2 Related Requirements

- A. Section 312323 - Fill: Material for filling holes, pits, and excavations generated as result of removal operations.

1.3 PROJECT CONDITIONS

- A. Minimize production of dust due to clearing operations; do not use water if that will result in ice, flooding, sedimentation of public waterways or storm sewers, or other pollution.

PART 2 - PRODUCTS - NOT USED

PART 3 - EXECUTION

3.1 Examination

- A. Comply with additional requirements specified in Section 017000 - Execution and Closeout Requirements.
- B. Identify potential runoff areas.
- C. Do not disrupt public utilities without permit from authority having jurisdiction.
- D. Protect existing structures and other elements that are to remain.
- E. Install sedimentation barrier according to Section 015713 - Temporary Erosion and Sediment Control.
- F. Develop dust remediation controls and methods. Do not use water if that results in ice, flooding, sedimentation of public waterways or storm sewers, or other pollution.

3.2 Preparation

- A. Coordinate work with utility companies; notify before starting work and comply with local requirements; obtain required permits.
- B. Protect existing utilities to remain from damage.
- C. Do not disrupt public utilities without permit from authority having jurisdiction.
- D. Protect existing structures and other elements that are to remain.
- E. Install sedimentation barrier according to Section 015713 - Temporary Erosion and Sediment Control.
- F. Develop dust remediation controls and methods. Do not use water if that results in ice, flooding, sedimentation of public waterways or storm sewers, or other pollution.

3.3 Clearing and Grubbing

- A. Clearing: Cut trees, stumps, shrubs, downed timber, and other vegetation for removal within identified area as indicated on drawings according to 29 CFR 1910.266. Follow recommendations of ANSI Z133 and best local practices for species involved.
- B. Clear site after relocating vegetation in accordance with ANSI A300 Part 6.
- C. Do not remove or damage vegetation beyond limits indicated on drawings.

3.4 Removed Vegetation Processing

- A. Do not burn, bury, landfill, or leave on-site, except as indicated on drawings.
- B. Trees: Sell if marketable.
- C. Chip, grind, crush, or shred vegetation for mulching, composting, or other purposes; give preference to on-site uses.

3.5 Repair and Restoration

- A. Remaining Existing Facilities, Utilities, and Site Features: If damaged due to this work, repair or replace to original condition.
- B. Vegetation: Replace damaged or destroyed vegetation identified to remain as indicated on drawings at no cost to Owner.
 - 1. Outside removal limits.

3.6 Debris Removal

- A. Remove debris, junk, and trash from site.
- B. Leave site in clean condition, ready for subsequent work.
- C. Clean up spillage and windblown debris from public and private lands.

3.7 Cleaning

- A. See Section 017000 - Execution and Closeout Requirements for additional requirements.
- B. Remove unused stockpiled subsoil. Grade stockpile area to prevent standing water.
- C. Leave site clean and ready to receive work.

END OF SECTION 311000

SECTION 312200
GRADING

PART 1 - GENERAL

1.1 Section Includes

- A. Rough grading the site for site structures, building pads, and retaining walls.
- B. Fine grading.

1.2 Related Requirements

- A. Section 311000 - Site Clearing.
- B. Section 312316 - Excavation.
- C. Section 312316.26 - Rock Removal.
- D. Section 312323 - Fill.

1.3 Submittals

- A. Project Record Documents: Accurately record actual locations of utilities remaining by horizontal dimensions, elevations or inverts, and slope gradients.

1.4 Quality Assurance

- A. Perform in accordance with State of Oregon, Highway Department standards.

1.5 PROJECT CONDITIONS

- A. Protect above- and below-grade utilities that remain.
- B. Protect plants, lawns, and other features to remain as a portion of final landscaping.
- C. Protect bench marks, survey control points, existing structures, fences, sidewalks, paving, and curbs from grading equipment and vehicular traffic.

PART 2 - PRODUCTS

2.1 Materials

- A. Gravel: Excavated on-site.
 - 1. Graded according to ASTM D2487 Group Symbol GW, GP, or SP.
- B. As specified in Section 312323 - Fill.

PART 3 - EXECUTION

3.1 Examination

- A. Verify survey bench mark and intended elevations for grading areas are as indicated.
- B. Verify the absence of standing or ponding water.

3.2 Preparation

- A. Identify required lines, levels, contours, and datum.
- B. Stake and flag locations of known utilities.
- C. Locate, identify, and protect above- and below-grade utilities to remain.
- D. Notify utility company to remove and relocate utilities.
- E. Provide temporary means and methods to remove standing or ponding water from areas prior to grading.

3.3 Rough Grading

- A. Excavate and fill subgrade material to elevations indicated on plans.
- B. Horizontally bench existing slopes greater than 1:4.
- C. Replace displaced subgrade in accordance with Section 312323.
- D. Remove and replace unsuitable materials as specified fill.

3.4 Fine Grading

- A. Scrape and spread subgrade material uniformly smooth and without disruptions as indicated on drawings.
- B. Slopes: Transition smoothly to adjacent areas.
- C. See Section 312323 for final compaction.

3.5 Cleaning

- A. See Section 017000 - Execution and Closeout Requirements for additional requirements.
- B. Remove unused stockpiled subsoil. Grade stockpile area to prevent standing water.
- C. Leave site clean and raked, ready to receive work.

END OF SECTION 312200

SECTION 312316
EXCAVATION

PART 1 - GENERAL

1.1 Section Includes

- A. Support and protection.
- B. Excavation.

1.2 Related Requirements

- A. Section 311000 - Site Clearing.
- B. Section 312200 - Grading.
- C. Section 312316.13 - Trenching. Excavating for utility trenches outside the building to utility main connections.
- D. Section 312316.26 - Rock Removal.
- E. Section 312323 - Fill.
- F. Section 312316.13 - Trenching: Excavating for utility trenches outside the building to utility main connections.

1.3 PROJECT CONDITIONS

- A. Verify that survey bench mark and intended elevations for the Work are as indicated.
- B. Protect plants, lawns, rock outcroppings, and other features to remain.
- C. Protect bench marks, survey control points, existing structures, fences, sidewalks, paving, and curbs from excavating equipment and vehicular traffic.

PART 2 - PRODUCTS (NOT USED)

PART 3 - EXECUTION

3.1 Examination

- A. Verify survey bench mark elevations are as indicated on drawings.
- B. Survey existing adjacent structures and exterior improvements to establish exact elevations at fixed points for bench marking.
- C. Assess adjacent structures and exterior improvements to establish existing conditions. Notify Engineer of existing cracks, sags, or other damages prior to starting work.

3.2 Preparation

- A. See Section 311000 for site clearing and topsoil removal.
- B. Identify required lines, levels, contours, and datum locations.
- C. Protect survey bench marks, control points, and monuments from excavating equipment and vehicular traffic.
- D. Protect existing structures, fences, sidewalks, paving, and curbs from excavating equipment and vehicular traffic.
- E. Protect plants, lawns, rock outcroppings, and other features to remain.
- F. Locate and identify known utilities to remain and protect from damage.

3.3 Support and Protection

- A. Excavation Safety: Comply with OSHA's Excavation Standard, 29 CFR 1926, Subpart P.
- B. Permanently leave in place excavation support and protection systems used as formwork or within 10 feet of existing foundations unless otherwise noted on drawings.
 - 1. Remove top 3 feet below grade.
- C. Remove support and protection systems not required to remain in place subject to approval of Engineer.
 - 1. Prevent harmful disturbance to underlying soils and damage to buildings, structures, pavements, facilities, and utilities.

3.4 Excavation

- A. General Excavation:
 - 1. Excavate to indicated contours, elevations, and grades.
- B. Excavation for Exterior Improvements:
 - 1. Excavate to subgrade; do not disturb subsoils.
 - 2. Compact subgrade as indicated on drawings.
- C. Excavation to accommodate foundations, underground tanks, and underground utilities.
 - 1. Excavate to specified elevations.
- D. See Section 312316.13 for trenching.
- E. Notify Engineer of unexpected subsurface conditions and discontinue affected work in area until notified to resume work.
- F. Slope banks of excavations deeper than 4 feet to angle of repose or less until shored.
- G. Do not interfere with 45-degree bearing splay of foundations.
- H. Cut utility trenches wide enough to allow inspection of installed utilities.
- I. Hand trim excavations. Remove loose matter.
- J. Correct areas that are over-excavated and load-bearing surfaces that are disturbed; see Section 312323.
- K. Remove excavated material that is unsuitable for re-use from site.
- L. Stockpile excavated material to be re-used in area designated on site 312200.
- M. Remove excess excavated material from site.

3.5 Field Quality Control

- A. See Section 014000 - Quality Requirements for additional requirements.
- B. Provide access for visual inspection of loadbearing excavated surfaces by Engineer before proceeding with work.
- C. Resurvey existing adjacent structure and exterior improvement bench marks. Notify Engineer of changes in elevations, positions, or slopes.
- D. Notify Engineer of additional cracks, sags, or other damages to adjacent structures or exterior improvements occurring during work.

3.6 Protection

- A. Divert surface water away from excavations.
- B. Keep excavations free of standing water.
- C. Maintain stability of banks and loose soils; prevent from falling into excavations.
- D. Maintain excavations in satisfactory, undisturbed condition.
- E. Protect bottom of excavations from freezing.

END OF SECTION 312316

SECTION 312316.13
TRENCHING

PART 1 - GENERAL

1.1 Section Includes

- A. Trench excavation.
- B. Utility bedding and cover.
- C. Backfill and compaction.

1.2 Related Requirements

- A. Section 311000 - Site Clearing.
- B. Section 312200 - Grading.
- C. Section 312316 - Excavation.
- D. Section 312316.26 - Rock Removal.
- E. Section 312323 - Fill.

1.3 Reference Standards

- A. AASHTO M 147 - Standard Specification for Materials for Aggregate and Soil-Aggregate Subbase, Base, and Surface Courses; 2017 (Reapproved 2021).
- B. AASHTO T 180 - Standard Method of Test for Moisture-Density Relations of Soils Using a 4.54-kg (10-lb) Rammer and a 457-mm (18-in.) Drop; 2025.
- C. ASTM C136/C136M - Standard Test Method for Sieve Analysis of Fine and Coarse Aggregates; 2025.
- D. ASTM D1556/D1556M - Standard Test Method for Density and Unit Weight of Soil in Place by Sand-Cone Method; 2015, with Editorial Revision (2016).
- E. ASTM D2167 - Standard Test Method for Density and Unit Weight of Soil in Place by the Rubber Balloon Method; 2015.
- F. ASTM D2487 - Standard Practice for Classification of Soils for Engineering Purposes (Unified Soil Classification System); 2017 (Reapproved 2025).
- G. ASTM D4318 - Standard Test Methods for Liquid Limit, Plastic Limit, and Plasticity Index of Soils; 2017, with Editorial Revision (2018).
- H. ASTM D698 - Standard Test Methods for Laboratory Compaction Characteristics of Soil Using Standard Effort (12,400 ft-lbf/ft³ (600 kN-m/m³)); 2012 (Reapproved 2021).
- I. ASTM D1557 - Standard Test Methods for Laboratory Compaction Characteristics of Soil Using Modified Effort (56,000 ft-lbf/ft³ (2,700 kN-m/m³)); 2012 (Reapproved 2021).

1.4 DEFINITIONS

- A. Finish Grade Elevations: Indicated on drawings.

1.5 Submittals

- A. See Section 013000 - Administrative Requirements for submittal procedures.
- B. Source Quality Control Submittals: Submit name of imported materials source.
 - 1. Results of gradation tests on proposed and actual materials used.
- C. Field Quality Control Submittals:
 - 1. Results of compaction density tests.
- D. Compaction Density Test Reports.

1.6 Delivery, Storage, and Handling

- A. See Section 017419 - Construction Waste Management and Disposal for packaging waste requirements.
- B. Deliver fill to project site in advance of need.
- C. When fill materials need on-site storage, locate stockpiles where acceptable to Owner and Agency Having Jurisdiction.
 - 1. Separate differing materials with dividers or stockpile separately to prevent intermixing.
 - 2. Prevent contamination.
 - 3. Protect stockpiles from erosion and deterioration of materials.
- D. Verify that survey bench marks and intended elevations for the Work are as indicated.
- E. Protect plants, lawns, and other features to remain.
- F. Protect bench marks, survey control points, existing structures, fences, sidewalks, paving, and curbs from excavating equipment and vehicular traffic.
 - 1. Separate differing materials with dividers or stockpile separately to prevent intermixing.
 - 2. Prevent contamination.
 - 3. Protect stockpiles from erosion and deterioration of materials.

PART 2 - PRODUCTS

2.1 Fill Materials

- A. General Fill: Composed of sand and gravel, free of shale, clay, friable materials, and debris.
- B. As specified in Section 312323 - Fill.

2.2 Source Quality Control

- A. See Section 014000 - Quality Requirements for additional requirements.
- B. Test fill materials in accordance with specified standard before delivery to site.
- C. Nonconforming Materials: Change and retest.
- D. Provide materials of each type from same source or as directed by Engineer.

PART 3 - EXECUTION

3.1 Examination

- A. Verify survey benchmarks and intended elevations for work are as indicated on drawings.
- B. Perform assessment of adjacent structures and exterior improvements to establish existing conditions. Notify Engineer of existing cracks, sags, or other damages prior to starting work.

3.2 Preparation

- A. Identify required lines, levels, contours, and datum locations.
- B. See Section 311000 for site clearing and topsoil removal.
- C. Locate and identify existing utilities to remain as indicated on drawings and protect from damage.

3.3 Trench Excavation

- A. Grade top perimeter of excavation to prevent surface water collection.
- B. Notify Engineer of unexpected subsurface conditions and discontinue affected work in area until notified to resume.
- C. General: Cut trenches neat and clean.
 - 1. Slope banks of excavations deeper than 5 feet to angle of repose or less until shored.
 - 2. Cut trenches wide enough to allow inspection of installed utilities.
 - 3. Hand trim excavations and remove loose matter.
 - 4. Remove large stones and other hard matter that could damage piping or impede consistent backfilling or compaction.
 - 5. Remove lumped subsoil, boulders, and rock up to 1/3 cu yd measured by volume.
 - 6. See Section 312316.26 for rock removal.
- D. Utility Preparation: Rake trench bottom to uniform grade.
 - 1. Remove unsuitable subgrade and backfill.
 - 2. Compact subgrade to density equal to or greater than subsequent fill material requirements.
- E. Maintain trenches and prevent loose soil or rocks from entering.
- F. Remove excavated material that is unsuitable for re-use from site.
- G. Remove excess excavated material from site.
- H. Provide temporary means and methods, as required, to remove all water from trenching until directed by the Engineer. Remove and replace soils deemed unsuitable by classification and which are excessively moist due to lack of dewatering or surface water control.

3.4 Utility Bedding and Cover

- A. Crushed Stone: Compact to 95 percent of maximum dry density.
 - 1. Bedding: Fill to subgrade elevation; rake smooth.
 - 2. Cover: Completely cover utility.

3.5 PREPARATION FOR UTILITY PLACEMENT

- A. Cut out soft areas of subgrade not capable of compaction in place. Backfill with Fill Type Granular.

- B. Compact subgrade to density equal to or greater than requirements for subsequent fill material.

- C. Until ready to backfill, maintain excavations and prevent loose soil from falling into excavation.

3.6 Backfill and Compaction

- A. Backfill to contours and elevations indicated on drawings using unfrozen materials.
- B. Fill to subgrade elevations unless otherwise indicated on drawings.
- C. Employ placement method that does not disturb or damage other work.
- D. Systematically fill to allow maximum time for natural settlement. Do not fill over porous, wet, frozen, or spongy subgrade surfaces.
- E. Maintain optimum moisture content of fill materials to attain required compaction density.
- F. Granular Fill: Place and compact materials in equal continuous layers in accordance with the Project Geotechnical Investigation and Site-Specific Seismic Hazard Study.
- G. Soil Fill: Place and compact materials in equal continuous layers in accordance with the Project Geotechnical Investigation and Site-Specific Seismic Hazard Study.
- H. Compaction densities shall be in accordance with the Project Geotechnical Investigation and Site-Specific Seismic Hazard Study.
- I. Granular Fill: Place and compact material in equal continuous layers not exceeding 8 inches compacted depth.
- J. Slope grade away from building minimum 2 inches in 10 feet, unless noted otherwise. Make gradual grade changes. Blend slope into level areas.
- K. Correct areas that are over-excavated.
 - 1. Thrust-Bearing Surfaces: Fill with concrete.
 - 2. Other Areas: Backfill, flush to required elevation, compacted to minimum 95 percent of maximum dry density.

L. Compaction Density Unless Otherwise Specified or Indicated:

- 1. Under paving, slabs-on-grade, and similar construction: 95 percent of maximum dry density.
 - 2. At Other Locations: 90 percent of maximum dry density.
- M. Reshape and re-compact fills subjected to vehicular traffic.
- N. Underground Warning Tape:
 - 1. Install 12 inches below finished grade, directly above buried pipe.

3.7 BEDDING AND FILL AT SPECIFIC LOCATIONS

- A. Utility Piping and Conduits:
- B. At Pipe Culverts:
- C. Over Subdrainage Piping at Foundation Perimeter and Under Slabs:
- D. At French Drains:

3.8 Tolerances

- A. Maximum Variation from Top Surface of General Backfilling: Plus or minus 1 inch from required elevations.

3.9 Field Quality Control

- A. See Section 014000 - Quality Requirements for general requirements for field inspection and testing.
- B. Perform compaction density testing on compacted fill in accordance with ASTM D1556, ASTM D2167, or ASTM D6938.
- C. Perform compaction density testing on compacted fill in accordance with ASTM D2922 or ASTM D3017.
- D. Evaluate results in relation to compaction curve determined by testing uncompacted material in accordance with ASTM D1557 modified proctor, AASHTO T 180, or ASTM D698 standard proctor.
- E. Nonconforming Work: For failed tests, remove work, replace, and retest.
- F. Frequency of Tests: In conformance with current Oregon APWA/ODOT Standard Specifications for Construction.

3.10 Cleaning

- A. See Section 017000 - Execution and Closeout Requirements for additional requirements.
- B. Stockpile excavated material re-used in area designated on-site; see Section 312200.
- C. Remove excavated material that is not required or unsuitable for re-use from site.

3.11 Protection

- A. Divert surface water away from excavations.
- B. Keep excavations free of standing water.
- C. Maintain stability of banks and loose soils; prevent from falling into excavations.
- D. Maintain excavations in neat and square, undisturbed condition.
- E. Protect bottom of excavations from freezing.

END OF SECTION 312316.13

SECTION 312316.26
ROCK REMOVAL

PART 1 - GENERAL

1.1 SECTION INCLUDES

- A. Removal of identified and discovered rock during excavation.

1.2 RELATED REQUIREMENTS

- A. Section 312323 - Fill: Fill materials.
- B. Project specific Geotechnical Design Report.

1.3 PRICE AND PAYMENT PROCEDURES

- A. Site Rock Removal: By the cubic yard measured before disintegration. Includes preparation of rock for removal, mechanical disintegration of rock, removal from position, loading and removing from site. For over excavation, payment will not be made for over excavated work nor for replacement materials.

- B. Trench Rock Removal: By the cubic yard measured before disintegration. Includes preparation of rock for removal, mechanical disintegration of rock, removal from position, loading and removing from site. For over excavation, payment will not be made for over excavated work nor for replacement materials.

1.4 DEFINITIONS

- A. Site Rock: Solid mineral material with a volume in excess of 1/3 cubic yard or solid material that cannot be removed with a 3/4 cubic yard capacity power shovel without drilling.
- B. Trench Rock: Solid mineral material with a volume in excess of 1/6 cubic yard or solid material that cannot be removed with a 3/4 cubic yard capacity power shovel without drilling.

PART 2 - PRODUCTS (NOT USED)

PART 3 - EXECUTION

3.1 EXAMINATION

- A. Verify site conditions and note subsurface irregularities affecting work of this section.

3.2 PREPARATION

- A. Identify required lines, levels, contours, and datum.

3.3 ROCK REMOVAL

- A. Excavate and remove rock by mechanical methods only; use of explosives is prohibited.
- B. Mechanical Methods: Drill holes and utilize expansive tools to fracture rock.
- C. Form level bearing at bottom of excavations.
- D. Remove shaled layers to provide sound and unshattered base for footings.
- E. In utility trenches, excavate to 6 inches below invert elevation of pipe and 24 inches wider than pipe diameter.
- F. Remove excavated materials from site.
- G. Correct unauthorized rock removal in accordance with backfilling and compacting requirements of Section 312323.

3.4 FIELD QUALITY CONTROL

- A. Independent agency field inspection will be provided under provisions of Section 014000 - Quality Requirements.

END OF SECTION 312316.26

SECTION 312323
FILL

PART 1 - GENERAL

1.1 SECTION INCLUDES

- A. Filling, backfilling, and compacting for building volume below grade, footings, slabs-on-grade, paving, site structures, utilities within the building, and retaining walls.
- B. Backfilling and compacting for utilities outside the building to utility main connections.
- C. Filling holes, pits, and excavations generated as a result of removal (demolition) operations.

1.2 RELATED REQUIREMENTS

- A. Reference: Project specific Geotechnical Design Report.
- B. Section 015713 - Temporary Erosion and Sediment Control: Slope protection and erosion control.
- C. Section 033000 - Cast-in-Place Concrete.
- D. Section 311000 - Site Clearing.
- E. Section 312200 - Grading: Site grading.
- F. Section 312316 - Excavation: Removal and handling of soil to be re-used.
- G. Section 312316.13 - Trenching: Excavating for utility trenches outside the building to utility main connections.
- H. Section 312316.26 - Rock Removal: Removal of rock during excavating.
- I. Section 334100 - Subdrainage: Filter aggregate and filter fabric for

- C. Materials Sources: Submit name of imported materials source.
- D. Fill Composition Test Reports: Results of laboratory tests on proposed and actual materials used, including manufactured fill.
- E. Compaction Density Test Reports.

1.6 DELIVERY, STORAGE, AND HANDLING

- A. When necessary, store materials on site in advance of need.
- B. Verify that survey bench marks and intended elevations for the Work are as indicated.

PART 2 - PRODUCTS

2.1 FILL MATERIALS

- A. General Fill: Base Aggregate: Complying with State of Oregon Highway Department standard. Structural fill materials shall be approved by the engineer of record prior to importing. All fill shall be free of organic and expansive clay material.

2.2 ACCESSORIES

- A. Geotextile Fabric: Non-biodegradable
 - 1. Non-woven: MIRAFL 140N or approved equal with laps per manufacturers specification.
 - 2. Woven: ACF WSF 200 or approved equal with laps per manufacturers specification.
 - 3. Filter: PROPEX GEOTEX 801 or approved equal.
 - 4. Waterproof Membrane: 10 mil. thick by StegoWrap or approved equal installed per manufacturers specification.

2.3 SOURCE QUALITY CONTROL

- A. See Section 014000 - Quality Requirements, for general requirements for testing and analysis of soil material.
- B. Where fill materials are specified by reference to a specific standard, test and analyze samples for compliance before delivery to site.
- C. If tests indicate materials do not meet specified requirements, change material and retest.
- D. Provide materials of each type from same source throughout the Work.

PART 3 - EXECUTION

3.1 EXAMINATION

- A. Identify required lines, levels, contours, and datum locations.
- B. See Section 312200 for additional requirements.
- C. Verify subdrainage, dampproofing, or waterproofing installation has been inspected.
- D. Verify structural ability of unsupported walls to support imposed loads by the fill.
- E. Verify areas to be filled are not compromised with surface or ground water.

3.2 PREPARATION

- A. Scarify and proof roll subgrade surface to a depth of 6 inches to identify soft spots.
- B. Cut out soft areas of subgrade not capable of compaction in place. Backfill with structural fill.
- C. Compact subgrade to density equal to or greater than requirements for subsequent fill material.
- D. Until ready to fill, maintain excavations and prevent loose soil from falling into excavation.

3.3 FILLING

- A. Fill to contours and elevations indicated using unfrozen materials.
- B. Fill up to subgrade elevations unless otherwise indicated.
- C. Employ a placement method that does not disturb or damage other work.
- D. Systematically fill to allow maximum time for natural settlement. Do not fill over porous, wet, frozen or spongy subgrade surfaces.
- E. Maintain optimum moisture content of fill materials to attain required compaction density.
- F. Granular Fill: Place and compact materials in equal continuous layers not exceeding 8 inches compacted depth.
- G. Slope grade away from building minimum 2 inches in 10 feet, unless noted otherwise. Make gradual grade changes. Blend slope into level areas.
- H. Correct areas that are over-excavated.
 - 1. Load-bearing foundation surfaces: Use general fill, flush to required elevation, compacted to 100 percent of maximum dry density.
 - 2. Other areas: Use general fill, flush to required elevation, compacted to minimum 95 percent of maximum dry density.
- I. Compaction Density Unless Otherwise Specified or Indicated:
- J. Reshape and re-compact fills subjected to vehicular traffic.
- K. Maintain temporary means and methods, as required, to remove all water while fill is being placed as required, or until directed by the Engineer. Remove and replace soils deemed unsuitable by classification and which are excessively moist due to lack of dewatering or surface water control.

3.4 FIELD QUALITY CONTROL

- A. See Section 014000 - Quality Requirements, for general requirements for field inspection and testing.
- B. Perform compaction density testing on compacted fill in accordance with ASTM D2922 or ASTM D3017.
- C. Evaluate results in relation to compaction curve determined by testing uncompacted material in accordance with AASHTO T 180, ASTM D1557 ("modified Proctor"), ASTM D698 ("standard Proctor"), AASHTO T 180, ASTM D1557 ("modified Proctor"), ASTM D698 ("standard Proctor"), AASHTO T 180, ASTM D1557 ("modified Proctor"), or ASTM D698 ("standard Proctor").
- D. If tests indicate work does not meet specified requirements, remove work, replace and retest.
- E. Frequency of Tests: In conformance with current Oregon APWA/ODOT Standard Specifications for Construction.
- F. Proof roll compacted fill at surfaces that will be under slabs-on-grade and paving.

3.5 CLEANING

- A. See Section 017419 - Construction Waste Management and Disposal, for additional requirements.
- B. Leave unused materials in a neat, compact stockpile.
- C. Remove unused stockpiled materials, leave area in a clean and neat condition. Grade stockpile area to prevent standing surface water.

END OF SECTION 312323

ONE INCH EQUALS FULL SCALE



OREGON TECH
3201 CAMPUS DR.
KLAMATH FALLS, OR 97601

**STILWELL
STADIUM
CANOPY**



Δ	DESCRIPTION	DATE

PROJECT NO:	K-6428-25
DESIGNED:	MEG, CMW
REVIEWED:	MKW
DATE:	03-11-2026

CIVIL EARTHWORK
SPECIFICATIONS

C0.04

BID & PERMIT SET NOT ISSUED FOR CONSTRUCTION

DIVISION 32 - EXTERIOR IMPROVEMENTS

SECTION 321120
SUBBASE AND AGGREGATE BASE COURSES

PART 1 - GENERAL

1.1 SECTION INCLUDES

- A. Geosynthetic reinforcement.
B. Aggregate base course.

1.2 RELATED REQUIREMENTS

- A. Section 312200 - Grading.
B. Section 312316.13 - Trenching.
C. Section 312323 - Fill.
D. Section 32 12 16 - Hot Mix Asphalt Paving
E. Section 321313 - Concrete Paving.

1.3 REFERENCE STANDARDS

- A. AASHTO M 147 - Standard Specification for Materials for Aggregate and Soil-Aggregate Subbase, Base, and Surface Courses; 2017 (Reapproved 2021).
B. AASHTO T 180 - Standard Method of Test for Moisture-Density Relations of Soils Using a 4.54-kg (10-lb) Rammer and a 457-mm (18-in.) Drop; 2025.
C. ASTM C136/C136M - Standard Test Method for Sieve Analysis of Fine and Coarse Aggregates; 2025.
D. ASTM D698 - Standard Test Methods for Laboratory Compaction Characteristics of Soil Using Standard Effort (12,400 ft-lbf/173 (600 kN-m3)); 2012 (Reapproved 2021).
E. ASTM D1556/D1556M - Standard Test Method for Density and Unit Weight of Soil in Place by Sand-Cone Method; 2015, with Editorial Revision (2016).
F. ASTM D1557 - Standard Test Methods for Laboratory Compaction Characteristics of Soil Using Modified Effort (56,000 ft-lbf/773 (2,700 kN-m3)); 2012 (Reapproved 2021).
G. ASTM D2167 - Standard Test Method for Density and Unit Weight of Soil in Place by the Rubber Balloon Method; 2015.
H. ASTM D2487 - Standard Practice for Classification of Soils for Engineering Purposes (Unified Soil Classification System); 2017 (Reapproved 2025).
I. ASTM D3665 - Standard Practice for Random Sampling of Construction Materials; 2024.
J. ASTM D4318 - Standard Test Methods for Liquid Limit, Plastic Limit, and Plasticity Index of Soils; 2017, with Editorial Revision (2018).
K. ASTM D6938 - Standard Test Methods for In-Place Density and Water Content of Soil and Soil-Aggregate by Nuclear Methods (Shallow Depth); 2023.

1.4 SUBMITTALS

- A. See Section 013000 - Administrative Requirements for submittal procedures.
B. Product Data: Geogrid indicating tensile strength.
C. Test Reports:
1. Aggregate Composition: Results of laboratory tests on proposed and actual materials used.
2. Compaction Density: Results of laboratory tests on compacted course.
D. Manufacturer's Instructions: Indicate geosynthetic installation procedure.
E. Source Quality Control Submittals: Submit name of imported materials source.

1.5 Delivery, Storage, and Handling

- A. When necessary, store materials on site in advance of need.
B. Deliver geosynthetic to project site wrapped in protective covering, maintain prior to use.
C. Aggregate Storage: Prevent material intermixing, contamination, and deterioration.

PART 2 - PRODUCTS

2.1 MATERIALS

- A. Geosynthetic:
1. Geotextile: Nonbiodegradable, woven.
a. ACF West Inc; WSF-200: https://www.acfwest.com/
2. Geocell Grid: High density polyethylene, perforated.
a. Cell Depth: 3 inches (76 mm).
b. Cell Area: 45 sq in (290 sq cm), nominal.
B. Aggregate Base Course:
1. Type General Fill : Comply with State of Oregon Highway Department standard.

2.2 SOURCE QUALITY CONTROL

- A. See Section 014000 - Quality Requirements for additional requirements.
B. If tests indicate materials do not meet specified requirements, change material and retest.
C. Provide materials of each type from same source throughout the Work.

PART 3 - EXECUTION

3.1 EXAMINATION

- A. Verify that survey bench marks and intended elevations for the work are as indicated.
B. Verify substrate has been inspected, and gradients and elevations are correct and dry.

3.2 PREPARATION

- A. Correct irregularities in substrate gradient and elevation by scarifying, reshaping, and recompactng.
B. Do not place aggregate on soft, muddy, or frozen surfaces.

3.3 PLACEMENT

A. Under Portland Cement Concrete Paving:

- 1. Install geosynthetic reinforcement on substrate in accordance with manufacturers instructions.
2. Aggregate Base Compacted Thickness: According to design drawings.
3. Compact to 95 percent of maximum dry density.
B. Under Hot Mix Asphalt Paving:
1. Install geosynthetic reinforcement on substrate in accordance with manufacturers instructions.
2. Aggregate Base Compacted Thickness: According to design drawings.
3. Compact to 95 percent of maximum dry density.
C. Place course in maximum 8 inch layers and roller compact to specified density.
D. Level and contour surfaces to elevations and gradients indicated.
E. Use mechanical tamping equipment in areas inaccessible to compaction equipment.

3.4 TOLERANCES

- A. Variation From Design Elevation: Within 1/2 inch.
B. Flatness: Maximum variation of 1/4 inch measured with 10 foot straight edge.

3.5 FIELD QUALITY CONTROL

- A. See Section 014000 - Quality Requirements for additional requirements.
B. Aggregate Base Compaction Density Testing: In accordance with ASTM D1556/D1556M, ASTM D2167, or ASTM D6938.
C. Evaluate results in relation to compaction curve determined by testing uncompacted material in accordance with AASHTO T 180, ASTM D698 ("standard Proctor"), or ASTM D1557 ("modified Proctor").
D. Frequency of Tests: In accordance with ASTM D3665.
E. Remove, replace, and retest work that does not meet specified requirements.
F. Proof roll compacted aggregate at surfaces going underneath rigid paving.

3.6 CLEANING

- A. See Section 017000 - Execution and Closeout Requirements for additional requirements.
B. Remove unused materials and grade areas to prevent standing surface water.

END OF SECTION 321120

SECTION 321216
HOT MIX ASPHALT PAVING

PART 1 - GENERAL

1.1 SECTION INCLUDES

- A. Single course asphalt concrete paving.

1.2 RELATED REQUIREMENTS

- A. Section 312200 - Grading: Preparation of site for paving and base.
B. Section 312323 - Fill: Compacted subgrade for paving.
C. Section 321120 - Subbase and Aggregate Base Courses.
D. Section 321313 - Concrete Paving: Concrete sidewalks.
E. Section 321713 - Parking Bumpers: Concrete bumpers.
F. Section 321723 - Pavement Markings.

1.3 QUALITY ASSURANCE

- A. Perform Work in accordance with State of Oregon Highways standard.
B. Mixing Plant: Complying with State of _____ Highways standard State of Oregon Highways standard.
C. Obtain materials from same source throughout.

1.4 REGULATORY REQUIREMENTS

1.5 FIELD CONDITIONS

- A. Do not place asphalt when ambient air or base surface temperature is less than 40 degrees F, or surface is wet or frozen.

PART 2 - PRODUCTS

2.1 MATERIALS

- A. Asphalt Cement shall conform with Oregon Standard Specifications for Construction - Section 00744.11.
B. Aggregate Materials shall conform with Oregon Standard Specifications for Construction - Section 00744.10.
C. Mix Type and Broadband Limits shall conform with Oregon Standard Specifications for Construction - Section 00744.12.
D. Job Mix Formula (JMF) Requirements: Job mix formula requirements shall conform with Oregon Standard Specifications for Construction - Section 00744.13.
E. Tolerances and Limits: Tolerance and limits shall conform with Oregon Standard Specifications for Construction - Section 00744.14.
F. HMAC Acceptance: HMAC acceptance shall conform with Oregon Standard Specifications for Construction - Section 00744.16.
G. Asphalt Cement: PG 64-28.
H. Aggregate for Base Course: In accordance with State of Oregon Highways standards.

2.2 EQUIPMENT

- A. Compactors: Compactors shall conform with Oregon Standard Specifications for Construction - Section 00744.24.

2.3 LABOR

- A. Quality Control Personnel: Provide quality control personnel in accordance with Oregon Standard Specifications for Construction - Section 00744.30.

2.4 ASPHALT PAVING MIXES AND MIX DESIGN

- A. Base Course: State of Oregon Highways standards, Level 2, 1/2" dense graded
B. Wearing Course: State of Oregon Highways standards, Level 2, 1/2" dense graded
C. Submit proposed mix design for review prior to beginning of work.

2.5 SOURCE QUALITY CONTROL

- A. Test mix design and samples in accordance with ODOT/APWA Standard Specifications for Construction..

PART 3 - EXECUTION

3.1 EXAMINATION

- A. Verify that compacted subgrade is dry and ready to support paving and imposed loads.
B. Verify gradients and elevations of base are correct.

3.2 AGGREGATE BASE COURSE

- A. Place and compact aggregate base course.
B. See Section 321120.

3.3 PREPARATION - TACK COAT

- A. Apply tack coat in accordance with manufacturer's instructions.
B. Apply tack coat on asphalt or concrete surfaces over subgrade surface at uniform rate of 1/3 gal/sq yd.
C. Apply tack coat to contact surfaces of curbs, gutters and other vertical edges.
D. Coat surfaces of manhole frames with oil to prevent bond with asphalt pavement. Do not tack coat these surfaces.

3.4 PLACING ASPHALT PAVEMENT - SINGLE COURSE

- A. Install Work in accordance with State of Oregon Highways standards.
B. Place asphalt to ____ inch compacted thickness 3 inch compacted thickness.
C. Compact pavement by rolling to specified density. Do not displace or extrude pavement from position. Hand compact in areas inaccessible to rolling equipment.
D. Perform rolling with consecutive passes to achieve even and smooth finish without roller marks.

3.5 TOLERANCES

- A. Flatness: Maximum variation of 1/4 inch measured with 10 foot straight edge.
B. Compacted Thickness: Within 1/4 inch of specified or indicated thickness.
C. Variation from True Elevation: Within 1/4 inch.

3.6 FIELD QUALITY CONTROL

- A. See Section 014000 - Quality Requirements, for general requirements for quality control.
B. Provide field inspection and testing. Take samples and perform tests in accordance with ODOT/APWA Standards.

3.7 PROTECTION

- A. Immediately after placement, protect pavement from mechanical injury for 5 days or until surface temperature is less than 140 degrees F.

END OF SECTION 321216

SECTION 321313
CONCRETE PAVING

PART 1 - GENERAL

1.1 Section Includes

- A. Paving assemblies.
B. Form materials.
C. Reinforcement.
D. Concrete materials.

1.2 Related Requirements

- A. Section 031000 - Concrete Forming and Accessories.
B. Section 033000 - Cast-in-Place Concrete.
C. Section 312200 - Grading: Preparation of site for paving and base and preparation of subsoil at pavement perimeter for paving.
D. Section 312323 - Fill: Compacted subbase for planting.
E. Section 321123 - Aggregate Base Courses: Aggregate base course.
F. Section 321713 - Parking Bumpers: Precast concrete parking bumpers.

1.3 Reference Standards

- A. ACI PRC-211.1 - Selecting Proportions for Normal-Density and High Density-Concrete - Guide; 2022.
B. ACI PRC-304 - Guide for Measuring, Mixing, Transporting, and Placing Concrete; 2000 (Reapproved 2009).
C. ACI SPEC-301 - Specifications for Concrete Construction; 2020.
D. ASTM A615/A615M - Standard Specification for Deformed and Plain Carbon-Steel Bars for Concrete Reinforcement; 2025.
E. ASTM A1064/A1064M - Standard Specification for Carbon-Steel Wire and Welded Wire Reinforcement, Plain and Deformed, for Concrete; 2024.
F. ASTM C33/C33M - Standard Specification for Concrete Aggregates; 2024a.
G. ASTM C39/C39M - Standard Test Method for Compressive Strength of Cylindrical Concrete Specimens; 2024.
H. ASTM C94/C94M - Standard Specification for Ready-Mixed Concrete; 2025.
I. ASTM C150/C150M - Standard Specification for Portland Cement; 2024.
J. ASTM C173/C173M - Standard Test Method for Air Content of Freshly Mixed Concrete by the Volumetric Method; 2024a.
K. ASTM C260/C260M - Standard Specification for Air-Entraining Admixtures for Concrete; 2024.

- L. ASTM C309 - Standard Specification for Liquid Membrane-Forming Compounds for Curing Concrete; 2025.
M. ASTM C494/C494M - Standard Specification for Chemical Admixtures for Concrete; 2024.
N. ASTM C618 - Standard Specification for Coal Ash and Raw or Calcined Natural Pozzolan for Use in Concrete; 2025a.
O. ASTM C685/C685M - Standard Specification for Concrete Made by Volumetric Batching and Continuous Mixing; 2025.
P. ASTM D1751 - Standard Specification for Preformed Expansion Joint Filler for Concrete Paving and Structural Construction (Nonextruding and Resilient Asphalt Types); 2023.
Q. ASTM D1752 - Standard Specification for Preformed Sponge Rubber, Cork, and Recycled PVC Expansion Joint Fillers for Concrete Paving and Structural Construction; 2018 (Reapproved 2023).

1.4 Submittals

- A. See Section 013000 - Administrative Requirements, for submittal procedures.
B. Product Data: Provide data on joint filler, admixtures, and curing compound.

1.5 QUALITY ASSURANCE

- A. Perform work in accordance with ACI 301.
B. Follow recommendations of ACI 305R when concreting during hot weather.
C. Follow recommendations of ACI 306R when concreting during cold weather.

1.6 ENVIRONMENTAL REQUIREMENTS

- A. Do not place concrete when base surface temperature is less than 40 degrees F, or surface is wet or frozen.

PART 2 - PRODUCTS

2.1 Paving Assemblies

- A. Comply with applicable requirements of ACI SPEC-301.
B. Concrete Sidewalks: 3,500 psi 28 day concrete, 4 inches thick, buff color Portland cement, trowel finish.

2.2 Form Materials

- A. Form Materials: As specified in Section 031000, comply with ACI SPEC-301.
B. Joint Filler: Preformed; non-extruding bituminous type (ASTM D1751) or sponge rubber or cork (ASTM D1752).
1. Thickness: 3/8 inch.
2. Products:

2.3 Reinforcement

2.4 Concrete Materials

- A. Obtain cementitious materials from same source throughout.
B. Concrete Materials: As specified in Section 033000.

2.5 Accessories

- A. Curing Compound: ASTM C309, Type 1, Class A.

2.6 Concrete Mix Design

- A. Concrete Strength: Establish required average strength for each type of concrete on the basis of field experience or trial mixtures, as specified in ACI SPEC-301.
1. For trial mixtures method, employ independent testing agency acceptable to Engineer for preparing and reporting proposed mix designs.
B. Admixtures: Add acceptable admixtures as recommended in ACI PRC-211.1 and at rates recommended by manufacturer.
C. Concrete Properties:
1. Compressive strength, when tested in accordance with ASTM C39/C39M at 28 days; 3,500 psi.
2. Total Air Content: 6 percent, determined in accordance with ASTM C173/C173M.
3. Maximum Slump: 4 inches.
4. Maximum Aggregate Size: 3/4 inch.

2.7 Mixing

- A. Transit Mixers: Comply with ASTM C94/C94M.

PART 3 - EXECUTION

3.1 Examination

- A. Verify compacted granular base is acceptable and ready to support paving and imposed loads.
B. Verify gradients and elevations of base are correct.

3.2 Subbase

- A. See Section 321120 for construction of base course for work of this Section.

3.3 Preparation

- A. Moisten base to minimize absorption of water from fresh concrete.
B. Notify Engineer minimum 24 hours prior to commencement of concreting operations.

3.4 Forming

- A. Place and secure forms to correct location, dimension, profile, and gradient.
B. Assemble formwork to permit easy stripping and dismantling without damaging concrete.
C. Place joint filler vertical in position, in straight lines. Secure to formwork during concrete placement. Hold top of pre-molded joint filler down 1/2" and seal upper 3/8" with approved joint seal material.

3.5 Placing Concrete

- A. Place concrete in accordance with ACI PRC-304.
B. Ensure reinforcement, inserts, embedded parts, formed joints are not disturbed during concrete placement.

- C. Place concrete continuously over the full width of the panel and between predetermined construction joints.
D. Place concrete to pattern indicated.

3.6 Joints

- A. Align joints with adjacent surfaces.
B. Place 3/8 inch wide expansion joints at 20 foot intervals and to separate paving from vertical surfaces and other components and in pattern indicated.
1. Form joints with joint filler extending from bottom of pavement to within 1/2 inch of finished surface.
2. Secure to resist movement by wet concrete.
C. Provide scored joints.
D. Install joints as specified on the plan set.

3.7 Finishing

- A. Area Paving: Light broom, texture perpendicular to pavement direction.
B. Place curing compound on exposed concrete surfaces immediately after finishing. Apply in accordance with manufacturer's instructions.

3.8 Tolerances

- A. Maximum Variation of Surface Flatness: 1/4 inch in 10 ft.
B. Maximum Variation From True Position: 1/4 inch.

3.9 Field Quality Control

- A. An independent testing agency will perform field quality control tests, as specified in Section 014000 - Quality Requirements.
1. Provide free access to concrete operations at project site and cooperate with appointed firm.
2. Submit proposed mix design of each class of concrete to inspection and testing firm for review prior to commencement of concrete operations.
3. Tests of concrete and concrete materials may be performed at any time to ensure compliance with specified requirements.
B. Compressive Strength Tests: ASTM C39/C39M; for each test, mold and cure three concrete test cylinders. Obtain test samples for every 100 cu yd or less of each class of concrete placed.
1. Take one additional test cylinder during cold weather concreting, cured on job site under same conditions as concrete it represents.
2. Perform one slump test for each set of test cylinders taken.
C. Maintain records of placed concrete items. Record date, location of pour, quantity, air temperature, and test samples taken.

3.10 Protection

- A. Immediately after placement, protect pavement from premature drying, excessive hot or cold temperatures, and mechanical injury.
B. Do not permit pedestrian traffic over pavement for 7 days minimum after finishing.

END OF SECTION 321313

SECTION 321710
PARKING BUMPERS AND MANUFACTURED TRAFFIC-CALMING DEVICES

PART 1 - GENERAL

1.1 SECTION INCLUDES

- A. Parking bumpers.

1.2 Related Requirements

- A. Section 321216 - Hot Mix Asphalt Paving.
B. Section 321313 - Concrete Paving.
C. Section 321723 - Pavement Markings.

1.3 Reference Standards

- A. ASTM A615/A615M - Standard Specification for Deformed and Plain Carbon-Steel Bars for Concrete Reinforcement; 2025.
B. ASTM C33/C33M - Standard Specification for Concrete Aggregates; 2024a.
C. ASTM C150/C150M - Standard Specification for Portland Cement; 2024.

1.4 Submittals

- A. See Section 013000 - Administrative Requirements for submittal procedures.
B. Product Data: Provide unit configuration and dimensions.

PART 2 - PRODUCTS

2.1 Parking Bumpers

- A. Nominal Size: 4-6 inches high, 6-8 inches wide, 5-7 feet long.
B. Profile: Manufacturer's standard.
C. Anchoring Holes: Two, spaced equally.

- D. Precast Concrete:
1. Cement: Portland Type I - Normal in accordance with ASTM C150/C150M.
2. Aggregate: Lightweight in accordance with ASTM C33/C33M.
3. Reinforcement: Deformed, unfinished steel bars in accordance with ASTM A615/A615M.
4. Color: Natural.

2.2 Accessories

- A. Anchors: Anchor spike.

PART 3 EXECUTION

3.1 Examination

- A. Verification of Conditions: Verify that asphalt pavement is ready to receive work, and pavement markings are dry.
1. See Section 321216.
2. See Section 321723.

3.2 Preparation

- A. Surface Preparation: Clean pavement surface and surrounding area.

3.3 Installation

- A. Install units without damage to shape or finish. Replace or repair damaged units.
B. Install units in alignment with adjacent work, as indicated on drawings.
C. Asphalt Pavement:
1. Position unit in place.
2. Drill through anchoring holes and full depth of asphalt pavement.
3. Hammer anchor spike flush with top of unit.
4. Fill anchor hole annular space with grout or sealant.

3.4 Field Quality Control

- A. See Section 014000 - Quality Requirements for additional requirements.
B. Inspect for placement, as indicated on drawings.
C. Nonconforming Work: Remove and reinstall.

END OF SECTION 321710

SECTION 321723
PAVEMENT MARKINGS

PART 1 - GENERAL

1.1 SECTION INCLUDES

- A. Painted pavement markings including parking bays, crosswalks, arrows, handicapped symbols, and curb markings.

1.2 RELATED REQUIREMENTS

- A. Section 321216 - Hot Mix Asphalt Paving.
B. Section 321713 - Parking Bumpers.

1.3 REFERENCE STANDARDS

- A. AASHTO M 249 - Standard Specification for White and Yellow Reflective Thermoplastic Striping Material (Solid Form); 2012 (Reapproved 2020).
B. AASHTO MP 24 - Standard Specification for Waterborne White and Yellow Traffic Paints; 2015 (Reapproved 2020).
C. ASTM D4505 - Standard Specification for Preformed Retroreflective Pavement Marking Tape for Extended Service Life; 2012 (Reapproved 2017).
D. FHWA MUTCD - Manual on Uniform Traffic Control Devices; 2023.

1.4 SUBMITTALS

- A. See Section 013000 - Administrative Requirements for submittal procedures.
B. Product Data: Manufacturer's data sheets on each product to be used.
C. Certificates: Submit for each batch stating compliance with specified requirements.
1. Painted pavement markings.

- D. Manufacturer's Instructions:
1. Preparation instructions and recommendations.
2. Storage and handling requirements and recommendations.
3. Installation methods.
E. Installer's qualification statement.

- F. Maintenance Materials: Furnish the following for Owner's use in maintenance of project.
1. See Section 016000 - Product Requirements for additional provisions.
2. Extra Paint: 2 containers, 1 gallon size, of each type and color.

1.5 QUALITY ASSURANCE

- A. Manufacturer Qualifications: Company specializing in manufacturing products specified in this section, with not less than three years of documented experience.
B. Installer Qualifications: Company specializing in performing work of the type specified and with at least three years of documented experience and approved by manufacturer.

1.6 DELIVERY, STORAGE, AND HANDLING

- A. Deliver paint in containers of at least 5 gallons accompanied by batch certificate.
B. Store products in manufacturer's unopened packaging until ready for installation.
C. Store and dispose of solvent-based materials, and materials used with solvent-based materials, in accordance with requirements of local authorities having jurisdiction.

1.7 FIELD CONDITIONS

- A. Do not install products under environmental conditions outside manufacturer's absolute limits.

PART 2 PRODUCTS

2.1 Painted Pavement Markings

- A. Painted Pavement Markings: As indicated on drawings.
1. Marking Paint: In accordance with AASHTO MP 24.
a. Parking Lots: White.
b. Symbols and Text: White.
c. Wheelchair Symbols: Provide blue and white.
2. Obliterating Paint: Type I, in accordance with AASHTO MP 24.
a. Bituminous Pavement: Black.
b. Concrete Pavement: Gray.

PART 3 EXECUTION

3.1 EXAMINATION

- A. Identify existing markings for removal.



- B. Verification of Conditions: Verify that pavement is dry and ready for installation.
- C. Notify Engineer of unsatisfactory conditions before proceeding.

3.2 PREPARATION

- A. Establish survey control points for locating and dimensioning of markings.
- B. Clean surfaces prior to installation.
 1. Remove dust, dirt, and other debris.
 2. Remove rubber deposits, existing paint markings, and other coatings.
- C. Apply paint stencils by type and color at necessary intervals.

3.3 INSTALLATION

- A. General:
 1. Position pavement markings as indicated on drawings.
 2. Field location adjustments require approval of Engineer.
- B. Painted Pavement Markings:
 1. Apply in accordance with manufacturer's instructions.
 2. Obliterating Paint: Apply as necessary to cover existing markings completely.
 3. Marking Paint: Apply uniformly, with sharp edges.
 - a. Applications: Two coats.
 - b. Wet Film Thickness: 0.015 inch, minimum.
 - c. Stencils: Lay flat against pavement, align with striping, remove after application.
 - d. Length Tolerance: Plus or minus 2 inches.
 - e. Width Tolerance: Plus or minus 1/8 inch.

3.4 TOLERANCES

- A. Maximum Variation From True Position: 3 inches (76 mm).
- B. Maximum Offset From True Alignment: 3 inches (76 mm).

3.5 FIELD QUALITY CONTROL

- A. See Section 014000 - Quality Requirements for additional requirements.
- B. If inspections indicate work does not meet specified requirements, rework and reinspect at no cost to Owner.
- C. Allow the pavement marking to set at least the minimum time recommended by manufacturer.

3.6 PROTECTION

- A. Prevent approaching traffic from crossing newly applied pavement markings.
- B. Replace damaged or removed markings at no additional cost to Owner.
- C. Preserve survey control points until pavement marking acceptance.

END OF SECTION 321723

SECTION 323223 SEGMENTAL RETAINING WALLS

PART 1 - GENERAL

1.1 SECTION INCLUDES

- A. Segmental retaining walls made of modular concrete units without soil reinforcement.
- B. Retaining wall units.
- C. Cap units.
- D. Drainage filter.
- E. Aggregate for leveling pad.
- F. Drainage fill.
- G. Reinforced backfill.
- H. Drainage pipe.

1.2 RELATED REQUIREMENTS

- A. Section 311000 - Site Clearing: Removal of unwanted trees, bushes, and debris.
- B. Section 312200 - Grading: Rough and fine grading.
- C. Section 312316 - Excavation.
- D. Section 312323 - Fill.
- E. Section 334100 - Subdrainage.

1.3 REFERENCE STANDARDS

- A. AASHTO M 288 - Standard Specification for Geosynthetics for Highway Applications; 2024.
- B. ASTM C920 - Standard Specification for Elastomeric Joint Sealants; 2018 (Reapproved 2024).
- C. ASTM C1372 - Standard Specification for Dry-Cast Segmental Retaining Wall Units; 2024.
- D. ASTM D422 - Standard Test Method for Particle-Size Analysis of Soils; 1963 (Reapproved 2007).
- E. ASTM D698 - Standard Test Methods for Laboratory Compaction Characteristics of Soil Using Standard Effort (12,400 ft-lb/ft³ (600 kN-m/m³)); 2012 (Reapproved 2021).
- F. ASTM D3034 - Standard Specification for Type PSM Poly(Vinyl Chloride) (PVC) Sewer Pipe and Fittings; 2024, with Editorial Revision (2025).
- G. ASTM D4491/D4491M - Standard Test Methods for Water Permeability of Geotextiles by Permittivity; 2022.
- H. ASTM D4632/D4632M - Standard Test Method for Grab Breaking Load and Elongation of Geotextiles; 2015a (Reapproved 2023).
- I. ASTM D4751 - Standard Test Methods for Determining Apparent Opening Size of a Geotextile; 2021a.

1.4 SUBMITTALS

- A. See Section 013000 - Administrative Requirements, for submittal procedures.

B. Segmental Retaining Wall Units:

1. Manufacturer's product data.
2. Project Record Documents.
3. Test data on unit strength and shear resistance between units.
4. Manufacturer's certification that units meet requirements of specification.
5. Storage and handling requirements and recommendations.
6. Installation methods.

C. Shop Drawings: Engineering drawings for installation, including elevations, large-scale details of elevations, typical sections, details, and connections, soil reinforcement, and drainage provisions.

1. Include marked up contract drawings showing exact dimensions for blocks, required coping, and other minor revisions.
2. Design Data: Submit detailed design calculations showing compliance with specified design criteria and material evaluations performed in accordance with specified design standard, signed and sealed by Design Engineer.

1.5 QUALITY ASSURANCE

- A. Pre-Construction Meeting: A meeting between the civil engineer, contractor, material supplier, subcontractors, and the owner shall be held to review the retaining wall design and construction requirements. A notification shall be sent to all parties at least seven (7) days in advance of the time of the meeting.
- B. Product Testing: Performed by qualified independent testing agency or by manufacturer and witnessed by qualified independent testing agency.

1.6 DELIVERY, STORAGE, AND HANDLING

- A. Confirm that the specified materials have been delivered. Provide a product certification with each shipment.
- B. Store products above ground on wood pallets or blocking, in manufacturer's unopened packaging, until ready for installation.
- C. Prevent excessive soil and mud from coming in contact with face of concrete units.
- D. Protect material from damage. Do not use damaged material. Remove damaged material from the site.
- E. Store and dispose of solvent-based materials, and materials used with solvent-based materials, in accordance with requirements of local authorities having jurisdiction.

PART 2 PRODUCTS

2.1 RETAINING WALLS

2.2 MATERIALS

- A. Retaining Wall Units: Machine-formed concrete blocks of shapes and sizes suitable for the retaining wall configuration required and complying with ASTM C1372 and the following:
 1. Face Color: Match existing units..
 2. Texture: Split face, on exposed surfaces.
 3. Face Shape: Straight (flat) with chamfered edges.
 4. Curved Walls: Provide unit shapes that accommodate the required curves without cutting and with gaps between faces of adjacent units of not more than 1/8 inch and a minimum radius of 3 1/2 feet.
 5. Acute Corners: Provide special shapes to form corners without cutting; exposed faces finished to match.
 6. Height: 6 inches, minimum. Match existing units.
 7. Length (Face Width): 16 inches, minimum. Match existing units.
 8. Width (Depth from Face): 12 inches, minimum, not including textured finish.
 9. Batter Ratio: Between 1 horizontal in 16 vertical and 1 horizontal to 6 vertical.
 10. Batter Dimensional Control: Provide integral positive control to maintain consistent batter dimension.
 11. Shear Resistance Mechanism: Manufacturer's standard.
 12. Moisture Absorption: 8 percent, maximum.
- B. Cap Units: Portland cement concrete machine-formed solid blocks, matching segmental retaining wall units, complying with ASTM C1372, with abutting edges saw cut or formed to provide tight fitting, flush end-to-end joints.
 1. Height: 4 inches, minimum.
 2. Width: Same as wall units.
 3. Depth: To fully cover wall units.
 4. Masonry Adhesive: To secure cap units as top course of wall.
 - a. Expected Life Span: 30 years.
 - b. Provide adhesive complying with ASTM C920, Type S, Grade NS, Class 25, and as approved by unit manufacturer.

C. Drainage Filter: Geosynthetic textile.

1. Tensile Strength (Grab) - Non-Woven: 115 pounds, when tested in accordance with ASTM D4632/D4632M.
2. Apparent Opening Size: 40 U.S. Sieve size, when tested in accordance with ASTM D4751.
3. Permittivity: 0.5 per second, minimum, when tested in accordance with ASTM D4491/D4491M.
4. Durability: Comply with minimum requirements of AASHTO M 288 Class 1; minimum mass of 8 ounces per square yard.

D. Aggregate for Leveling Pad: Compacted sand, gravel, or crushed rock complying with one of the following:

1. As specified in Section 312323.
- E. Drainage Fill: Clean, freely draining aggregate placed within, between, or immediately behind segmental retaining wall units; do not use pea gravel; use one of the following:
 1. Aggregate as approved by Engineer.

- F. Backfill: Compacted soil placed behind drainage fill ; do not use heavy clay or organic soils; comply with one of the following:
 1. Use site-excavated or other soil approved by Engineer.

- G. Drainage Pipe: 4 inch Perforated schedule 40 PVC, complying with ASTM D3034; or corrugated HDPE complying with ASTM F405; with geotextile filter wrap.

PART 3 EXECUTION

3.1 INSTALLERS

- A. The constructor and site supervisor shall have successfully completed several projects including the installation of at least three gravity wall systems (or similar). The contractor shall carry adequate insurance and bond.

3.2 EXAMINATION

- A. Verify location of existing structures and utilities prior to excavation.
- B. Protect adjacent structures from the effects of excavation.
- C. Verify that layout dimensions are correct and substrate is in proper condition for installation.
- D. Notify Engineer of unsatisfactory conditions.
- E. Do not proceed with installation until unsatisfactory conditions have been corrected.

3.3 PREPARATION

- A. Sitework:
 1. Remove unwanted trees, bushes, and debris as specified in Section 311000.
- B. Excavation:
 1. Excavate to lines and grades indicated on drawings.
 2. Do not disturb embankment or foundation beyond lines. Minimize over-excavation; fill over-excavated areas with compacted reinforced backfill or leveling pad material at Contractor's expense.
 3. After excavation, and prior to placement of leveling materials, Engineer will examine bearing soil surface to verify strength meets or exceeds design requirements and assumptions.
 4. Replace unsuitable bearing soil as directed by Engineer.
 5. Provide means of controlling surface water away from excavation during construction.
- C. Leveling Pad:
 1. Depth: 4 inches, minimum.
 2. Width: 6 inches minimum extension beyond front and back faces of units.
 3. In lieu of pad made solely of aggregate or concrete, pad may be 3 inches, minimum, of thick compacted sand or crushed rock, covered with 2 inches to 3 inches of unreinforced concrete.
 4. Location: Top of pad at 1 inch below grade for each 8 inches that wall extends above grade.
 5. Compact aggregate to lines and grades on drawings, in lifts 6 inches thick, maximum.
 6. Compact aggregate to a minimum of 95 percent standard Proctor density, when determined in accordance with ASTM D698 .
 7. Use only hand-operated compaction equipment within 36 inches of back of wall.
- D. Verify level grade before proceeding.
- E. Install drainage collection pipe with a continuous fall in the direction of flow. Cap open ends as necessary to prevent soil and debris from entering.

3.4 INSTALLATION

- A. Install in accordance with drawings, manufacturer instructions, and applicable codes and regulations.
- B. Segmental Retaining Wall Units:
 1. Place first course of units on leveling pad; check alignment and level. Check for full contact with base and for stability.
 2. Place units side by side for full length of wall, aligning back face of straight walls using string line or offset from base line and back face of curved walls using flexible pipe or other method recommended by manufacturer.
 3. Do not leave gaps between units.
 4. Lay out corners and curves in accordance with manufacturer's instructions. Do not leave gaps to produce wall batter or curvature.
 5. Cut blocks with saw; do not split units.
 6. Sweep excess material from tops of units before laying succeeding courses.
 7. Place a maximum of 2 succeeding courses above level backfill. Check for proper alignment and batter.
 8. Where top of wall changes elevation, step units to match grade or turn top course into embankment.
 9. Where bottom of wall changes elevation, step base leveling pad and extend lowest course a minimum of two units into slope.
 10. Install shear connectors per manufacturer recommendations.
- C. Drainage Fill: Place drainage fill in, between, and behind units.
 1. Compact to lines and grades on drawings, in lifts 6 inches thick, maximum; decrease lift thickness where necessary to achieve required density.
 2. Extend drainage fill 12 inches beyond back face of units.
 3. Base of drainage fill elevation shall not exceed two courses or 16 inches from base of wall units.
- D. Backfill: Place, spread, and compact backfill from behind drainage fill to undisturbed soil while minimizing the development of slack in the soil reinforcement.
 1. Use only lightweight hand-operated compaction equipment within 3 feet from back wall face, or one half of wall height, whichever is greater.
 2. Place backfill in lifts of maximum 6 inches to 8 inches loose thickness where hand compaction is used and 8 inches to 10 inches where heavy compaction equipment is used.
 3. Compact backfill to 95 percent maximum density and upper 2 feet of backfill to 98 percent maximum density, standard Proctor, as determined in accordance with ASTM D698.

- 4. Moisture content of backfill prior to and during compaction to be within plus or minus 2 percentage points dry of optimum and uniform throughout each layer.
 - 5. Do not operate tracked construction equipment directly upon soil reinforcement. Maintain a minimum fill thickness of 6 inches for operation of tracked vehicles over soil reinforcement. Minimize turning of tracked vehicles while over soil reinforcement.
 - 6. Operate wheeled equipment at speeds less than 10 miles per hour over soil reinforcement.
 - 7. Prevent contamination of the filter fabric, unit fill, blanket drains, chimney drains, and/or drainage composite from poor drainage materials such as fine grained silt and clay.
 - 8. At end of each day, slope top of backfill away from wall to direct runoff away from wall face. Prevent runoff from adjacent areas from entering wall site.
 - 9. At completion, if other work adjacent to wall is not to be done immediately (paving, landscaping, etc), grade top of backfill and provide temporary drainage to prevent water runoff toward the wall.
- E. Cap Units:** Install and top two courses of units with masonry adhesive.
1. Verify in-place top of wall elevation prior to installation of cap units and adjust accordingly.
 2. Clear cap units and top course of segmental retaining wall units of debris and standing water before applying adhesive.
 3. Apply masonry adhesive to top surface of top unit and place cap into position over projecting pins. Protect wall face from masonry adhesive.

- F. Site Drainage:**
1. At end of each day:
 - a. Grade backfill a minimum of 2 percent away from wall to prevent runoff from adjacent areas from entering wall site and to prevent ponding at the wall.
 - b. Construct a berm at the crest of the wall to prevent surface water from overtopping.
 2. At completion, if other work adjacent to wall is not to be done immediately (paving, landscaping, etc), grade top of backfill and provide temporary drainage to prevent water runoff toward the wall.
 3. Surface water control and groundwater seepage shall be the responsibility of the project Engineer.

3.5 TOLERANCES

- A. Top of Wall:
 1. Plan Location: Maximum of plus/minus 1 inch from plan location.
 2. Elevation: Maximum of plus/minus 1-1/2 inch from elevations shown on drawings.
- B. Face of Wall Flatness: Measured as deviation from a straight edge.
 1. In the Vertical Dimension: Plus/minus 1/8 inches per one foot section.
 2. In the Horizontal Dimension of Straight Walls: Plus/minus 1-1/2 inch per 10 foot section.
- C. Overall Wall Batter: Within plus/minus 1/8 inch per one foot shall be allowed, measured from the vertical.
- D. Gap Between Adjacent Units: 1/8 inch, maximum.

3.6 CLEANING

- A. Clean wall face to remove debris and stains.
- B. Leave adjacent paved areas broom clean.

3.7 PROTECTION

- A. Prevent damage to wall and earthwork by subsequent construction and uncontrolled runoff until substantial completion; repair damage due to failure to protect wall or earthwork.
- B. Do not operate heavy paving or grading equipment within 36 inches from the back of the wall face.
- C. Do not operate equipment with wheel loads in excess of 150 pounds per square foot live load within 10 feet from the wall face.
- D. Do not place temporary soil or fill stockpiles adjacent to wall.
- E. Replace damaged units prior to Date of Substantial Completion.

END OF SECTION 323223

ONE INCH EQUALS FULL SCALE



OREGON TECH
3201 CAMPUS DR.
KLAMATH FALLS, OR 97601

STILWELL STADIUM CANOPY

Oregon TECH
Oregon Institute of Technology



DESCRIPTION	DATE

PROJECT NO: K-6428-25
DESIGNED: MEG, CMW
REVIEWED: MKW
DATE: 03-11-2026

CIVIL EXTERIOR IMPROVEMENTS SPECIFICATIONS

C0.06

BID & PERMIT SET NOT ISSUED FOR CONSTRUCTION

DIVISION 33 - UTILITIES

**SECTION 334100
SUBDRAINAGE**

PART 1 - GENERAL

1.1 SECTION INCLUDES

- A. Retaining Wall Drainage Systems.
- B. Filter aggregate and fabric and bedding.

1.2 RELATED REQUIREMENTS

- A. Section 312316 - Excavation: Excavating for subdrainage system piping and surrounding filter aggregate.
- B. Section 312316.13 - Trenching: Excavating and backfilling for site subdrainage systems.
- C. Section 312323 - Fill: Backfilling over filter aggregate, up to subgrade elevation.

1.3 REFERENCE STANDARDS

- A. ASTM D2729 - Standard Specification for Poly(Vinyl Chloride) (PVC) Sewer Pipe and Fittings; 2021.

1.4 SUBMITTALS

- A. See Section 013000 - Administrative Requirements, for submittal procedures.
- B. Manufacturer's Certificate: Certify that products meet or exceed specified requirements.
- C. Project Record Documents: Record location of pipe runs, connections, cleanouts and principal invert elevations.

PART 2 - PRODUCTS

2.1 PIPE MATERIALS

- A. Polyvinyl Chloride Pipe: ASTM D 2729; plain end, 4 inch inside diameter (see plan); with required fittings.
- B. Corrugated Plastic Tubing: Flexible type; 4 inch diameter, with required fittings.
- C. Use perforated pipe at subdrainage system; unperforated through sleeved walls.

2.2 AGGREGATE AND BEDDING

- A. Filter Aggregate and Bedding Material: Granular fill as specified in Section 312323.

2.3 ACCESSORIES

- A. Pipe Couplings: Solid plastic.
- B. Filter Fabric: Water pervious type, black polyolefin. Provide PROPOX GEOTEX 801 manufactured by Propex Geosolutions .Refer to Section 312323. Geotextile Fabric - Filter

PART 3 - EXECUTION

3.1 EXAMINATION

- A. Verify that trench cut is ready to receive work and excavations, dimensions, and elevations are as indicated on layout drawings.

3.2 PREPARATION

- A. Hand trim excavations to required elevations. Correct over-excavation with approved 3/4" minus ODOT spec.
- B. Remove large stones or other hard matter that could damage drainage piping or impede consistent backfilling or compaction.

3.3 INSTALLATION

- A. Install and join pipe and pipe fittings in accordance with pipe manufacturer's instructions.
- B. Place drainage pipe on compacted impervious fill.
- C. Lay pipe to slope gradients noted on drawings; with maximum variation from true slope of 1/8 inch in 10 feet.
- D. Place pipe with perforations facing down. Mechanically join pipe ends.
- E. Install filter aggregate at sides, over joint covers and top of pipe. Provide top cover compacted thickness of 12 inches.
- F. Place filter fabric around and over levelled top surface of Drainage Fill aggregate cover prior to subsequent backfilling operations.
- G. Refer to Section 312323 for compaction requirements. Do not displace or damage pipe when compacting.
- H. Connect to storm sewer system with unperforated pipe, through installed sleevesat locations indicated on plan.

3.4 FIELD QUALITY CONTROL

- A. Section 014000 - Quality Requirements: Field inspection and testing.
- B. Request inspection prior to and immediately after placing aggregate cover over pipe.

3.5 PROTECTION

- A. Protect pipe and aggregate cover from damage or displacement until backfilling operation begins.

END OF SECTION 334100

**SECTION 334211
SITE STORM UTILITY DRAINAGE PIPING**

PART 1 - GENERAL

1.1 SECTION INCLUDES

- A. Stormwater drainage piping.
- B. Stormwater pipe accessories.

1.2 RELATED REQUIREMENTS

- A. Section 033000 - Cast-in-Place Concrete: Concrete for cleanout base pad construction.
- B. Section 312316 - Excavation: Excavating of trenches.
- C. Section 312316.13 - Trenching: Excavating, bedding, and backfilling.
- D. Section 312323 - Fill: Bedding and backfilling.

1.3 REFERENCE STANDARDS

- A. AASHTO M 252 - Standard Specification for Corrugated Polyethylene Pipe, 75- to 250-mm (3- to 10-in.) Diameter; 2025.
- B. AASHTO M 294 - Standard Specification for Corrugated Polyethylene Pipe, 300- to 1500-mm (12- to 60-in.) Diameter; 2025.
- C. ASTM A48/A48M - Standard Specification for Gray Iron Castings; 2022.
- D. ASTM D1785 - Standard Specification for Poly(Vinyl Chloride) (PVC) Plastic Pipe, Schedules 40, 80, and 120; 2021a.
- E. ASTM D2321 - Standard Practice for Underground Installation of Thermoplastic Pipe for Sewers and Other Gravity-Flow Applications; 2025.
- F. ASTM D2680 - Standard Specification for Acrylonitrile-Butadiene-Styrene (ABS) and Poly(Vinyl Chloride) (PVC) Composite Sewer Piping, 2020 (Reapproved 2025).
- G. ASTM D2729 - Standard Specification for Poly(Vinyl Chloride) (PVC) Sewer Pipe and Fittings; 2021.
- H. ASTM D3034 - Standard Specification for Type PSM Poly(Vinyl Chloride) (PVC) Sewer Pipe and Fittings; 2024, with Editorial Revision (2025).
- I. ASTM D3350 - Standard Specification for Polyethylene Plastics Pipe and Fittings Materials; 2024.
- J. ASTM F 405 - Standard Specification for Corrugated Polyethylene Drainage Pipe and Fittings in Nominal sizes 3 inches to 6 inches in diameter.
- K. ASTM F 477 - Standard Specification for Elastomeric Seals (gaskets) for Joining Pipe.
- L. ASTM F 667 - Standard Specification for Large Diameter Corrugated Polyethylene Drainage Pipe and Fittings in Nominal sizes 8 inches to 24 inches in diameter.

1.4 DEFINITIONS

- A. Bedding: Fill placed under, beside and directly over pipe, prior to subsequent backfill operations.

1.5 SUBMITTALS

- A. See Section 013000 - Administrative Requirements, for submittal procedures.
- B. Product Data: Provide data indicating pipe, pipe accessories.
- C. Manufacturer's Installation Instructions: Indicate special procedures required to install Products specified.
- D. Project Record Documents:
 - 1. Record location of pipe runs, connections, and invert elevations.
 - 2. Identify and describe unexpected variations to subsol conditions or discovery of uncharted utilities.

1.6 REGULATORY REQUIREMENTS

- A. Conform to applicable code for materials and installation of the Work of this section.

1.7 PROJECT CONDITIONS

- A. Coordinate the Work with termination of storm sewer connection outside building, trenching, connection to foundation drainage system.

PART 2 - PRODUCTS

2.1 STORMWATER PIPE MATERIALS

- A. Corrugated HDPE Pipe and Fittings: ASTM F 2306.
- B. Corrugated HDPE Pipe and Fittings: ASTM F 2648.
- C. Plastic Pipe: ASTM D3034, Type PSM, Poly Vinyl Chloride (PVC) material; inside nominal diameter of per plan inches, bell and spigot style solvent sealed joint end.
- D. Polyethylene Pipe: Corrugated HDPE pipe and fittings, Hancor Sur-Lok or ADS N-12 (all pipe joints to be water tight).

2.2 PIPE ACCESSORIES

- A. Elastomeric Seals (Gaskets): ASTM F 477.
- B. Trace Wire: Magnetic detectable conductor, brightly colored green plastic covering, imprinted with "Storm Sewer Service " in large letters.
- C. Downspout Boots: Smooth interior without boxed corners or choke points; include integral lug slots and on-body cleanout and cover with neoprene gaskets.
 - 1. Configuration: Angular.
 - 2. Material: Cast iron; ASTM A48/A48M; casting thickness 3/8 inch (9.5 mm), minimum.
 - 3. Finish: Manufacturer's standard factory applied primer finish.
 - 4. Color: To be selected by Architect from manufacturer's standard range.
 - 5. Accessories: Manufacturer's standard stainless steel fasteners, stainless steel building wall anchors, and rubber coupling.
 - 6. Manufacturers:
 - a. Downspoutboots.com, a division of J. R. Hoe & Sons; ____; www.downspoutboots.com/#se.

2.3 BEDDING AND COVER MATERIALS

- A. Bedding: As specified in Section 312316.13.
- B. Cover: As specified in Section 312316.13.

PART 3 - EXECUTION

3.1 TRENCHING

- A. See Section 312316.13 - Trenching for additional requirements.
- B. Backfill around sides and to top of pipe with cover fill, tamp in place and compact, then complete backfilling.

3.2 INSTALLATION

- A. Verify that trench cut is ready to receive work and excavations, dimensions, and elevations are as indicated on layout drawings.
- B. Install pipe, fittings, and accessories in accordance with manufacturer's instructions. Seal watertight.
 - 1. Plastic Pipe: Also comply with ASTM D2321.
- C. Lay pipe to slope gradients noted on layout drawings; with maximum variation from true slope of 1/8 inch in 10 feet.

- D. Connect to building storm drainage system, foundation drainage system, and utility/municipal system.

- E. Install continuous trace wire 6 inches above top of pipe; coordinate with Section 312316.13.

3.3 FIELD QUALITY CONTROL

- A. Perform field inspection in accordance with Section 014000 - Quality Requirements.
- B. If tests indicate Work does not meet specified requirements, remove Work, replace and retest at no cost to Owner.
- C. Pressure Test: Test in accordance with Oregon Plumbing Specialty Code.
- D. Deflection Test: Test in accordance with Oregon Plumbing Specialty Code.

3.4 PROTECTION

- A. Protect pipe and bedding cover from damage or displacement until backfilling operation is in progress.

END OF SECTION 334211



900 Klamath Avenue
Klamath Falls, OR 97601
541.884.7421

OREGON TECH
3201 CAMPUS DR.
KLAMATH FALLS, OR 97601

**STILWELL
STADIUM
CANOPY**



Oregon Institute of Technology



DESCRIPTION	DATE

PROJECT NO: K-6428-25
DESIGNED: MEG, CMW
REVIEWED: MKW
DATE: 03-11-2026

CIVIL UTILITIES
SPECIFICATIONS



C0.07

ONE INCH EQUALS FULL SCALE

BID & PERMIT SET NOT ISSUED FOR CONSTRUCTION

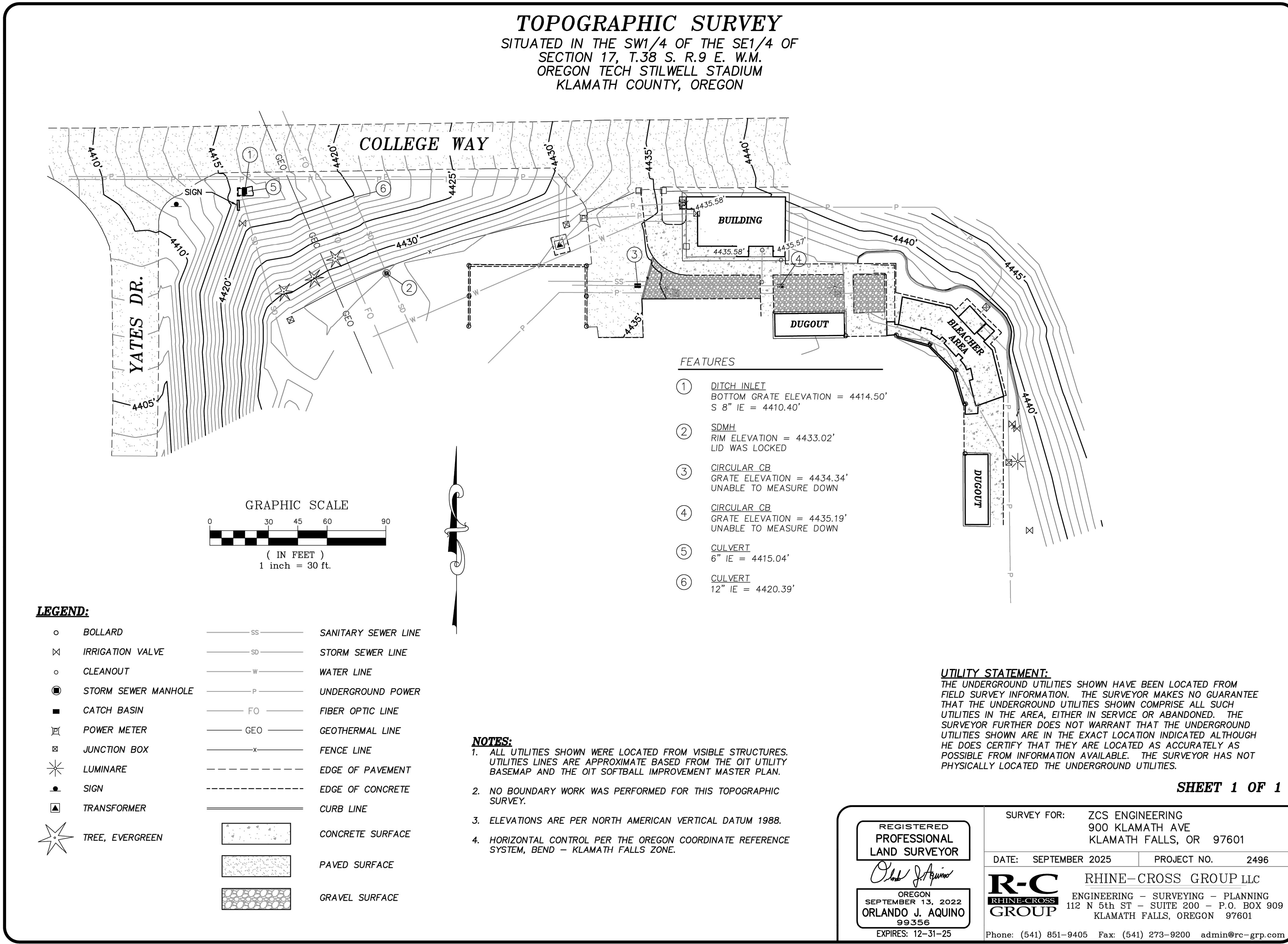
ATTENTION:
TOPOGRAPHIC SURVEY BY OTHERS.
INCLUDED IN THIS PLAN SET FOR REFERENCE.
CONTACT PROJECT SURVEYOR FOR
ADDITIONAL INFORMATION, IF NECESSARY

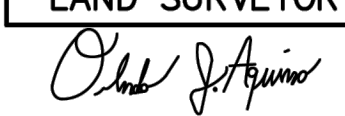

REGISTERED PROFESSIONAL LAND SURVEYOR  OREGON SEPTEMBER 13, 2022 ORLANDO J. AQUINO 99356 EXPIRES: 12-31-25	SURVEY FOR: ZCS ENGINEERING 900 KLAMATH AVE KLAMATH FALLS, OR 97601	
	DATE: SEPTEMBER 2025	PROJECT NO. 2496
 RHINE-CROSS GROUP LLC ENGINEERING - SURVEYING - PLANNING 112 N 5th ST - SUITE 200 - P.O. BOX 909 KLAMATH FALLS, OREGON 97601 Phone: (541) 851-9405 Fax: (541) 273-9200 admin@rc-grp.com		

FOR INFORMATION ONLY

DESCRIPTION	DATE

PROJECT NO: K-6428-25
DESIGNED: MEG, CMW
REVIEWED: MKW
DATE: 03-11-2026

TOPOGRAPHIC
SURVEY

C0.30

BID & PERMIT SET | NOT ISSUED FOR CONSTRUCTION



900 Klamath Avenue
Klamath Falls, OR 97601
541.884.7421

OREGON TECH
3201 CAMPUS DR.
KLAMATH FALLS, OR 97601

STILWELL
STADIUM
CANOPY

Oregon TECH
Oregon Institute of Technology

LEGEND

EXISTING

HATCHES & LINE TYPES:

- BUILDING
- BUILDING OVERHANG
- ASPHALT
- FENCING
- SURFACE CONTOUR - MAJOR
- SURFACE CONTOUR - MINOR
- FIBER
- GEOTHERMAL
- STORM SEWER
- SANITARY SEWER
- WATER
- BURIED POWER

SYMBOLS:

- CLEANOUT TO GRADE
- STORM MANHOLE
- AREA DRAIN
- DITCH INLET
- POWER METER
- JUNCTION BOX
- POWER TRANSFORMER
- POWER HANDHOLD
- WATER VALVE
- IRRIGATION VALVE
- IRRIGATION BOX
- SITE LIGHT
- BOLLARD
- SIGN
- TREE - CONIFER

DEMOLITION AND ESC

HATCHES, LINE TYPES & SYMBOLS:

- ASPHALT PAVING TO BE REMOVED
- GRAVEL SURFACING TO BE REMOVED
- DECOMPOSED GRANITE TO BE STOCKPILED
- CLEARING AND GRUBBING LIMITS
- SAWCUT LINE
- PRIVATE UTILITY TO BE REMOVED
- JUNCTION BOX
- CONCRETE TRUCK WASHOUT
- TYPE 3 INLET PROTECTION
- TYPE 4 INLET PROTECTION

DEMOLITION & PROTECTION NOTES:

GENERAL DEMOLITION & PROTECTION NOTES:
CONTRACTOR SHALL REPORT TO ENGINEER FOR DIRECTION IN EVENT OF DISCREPANCIES BETWEEN PLANS AND FIELD CONDITIONS.

EXISTING STRUCTURES, HARDSCAPE, AND UTILITIES/APPURTENANCES SHALL BE PROTECTED THROUGHOUT ALL PHASES OF CONSTRUCTION, UNLESS OTHERWISE NOTED.

CONTRACTOR SHALL COORDINATE VEHICULAR AND PEDESTRIAN ACCESS REQUIREMENTS WITH OWNER PRIOR TO CONSTRUCTION.

- NOTES:**
101. ASPHALT PAVING TO BE REMOVED. SAWCUT AT APPROXIMATE ALIGNMENT SHOWN.
 102. GRAVEL PAVING TO BE REMOVED.
 103. DECOMPOSED GRANITE TO BE REMOVED AND STORED ON SITE FOR REUSE OUTSIDE LIMITS OF DISTURBANCE BEHIND EXISTING BLEACHERS OR IN GRAVEL LOT NORTH OF YATES DRIVE INTERSECTION.
 104. APPROXIMATE LIMITS OF CLEARING AND GRUBBING.
 105. EXISTING BLOCK RETAINING WALL TO BE CAREFULLY DISMANTLED. CONTRACTOR SHALL STORE BLOCKS ON SITE FOR REUSE. PERFORATED WALL DRAIN TO BE DEMOLISHED.
 106. EXCAVATION FOR NEW CANOPY FOOTINGS. TYPICAL REFER TO ARCHITECTURAL AND STRUCTURAL PLANS FOR MORE INFORMATION.
 107. INSTALL TYPE 3 INLET PROTECTION AS SHOWN PER ODOT STANDARD DRAWING RD1010.
 108. INSTALL TYPE 4 DITCH INLET PROTECTION AS SHOWN PER ODOT STANDARD DRAWING RD1015.
 109. INSTALL CONCRETE TRUCK WASHOUT AS SHOWN PER ODOT STANDARD DRAWING RD1070.
 110. STORMLINE TO BE REMOVED BETWEEN KEYNOTES.
 111. POWER CONDUIT TO BE REMOVED BETWEEN KEYNOTES.
 112. CONCRETE SLAB AT PRESS-BOX TO BE UNDERMINED AS REQUIRED TO FACILITATE CONSTRUCTION OF NEW CANOPY FOOTINGS. REFER TO STRUCTURAL PLANS FOR ADDITIONAL INFORMATION.
 113. UTILITY APPURTENANCE TO BE ADJUSTED TO FINISH GRADE.

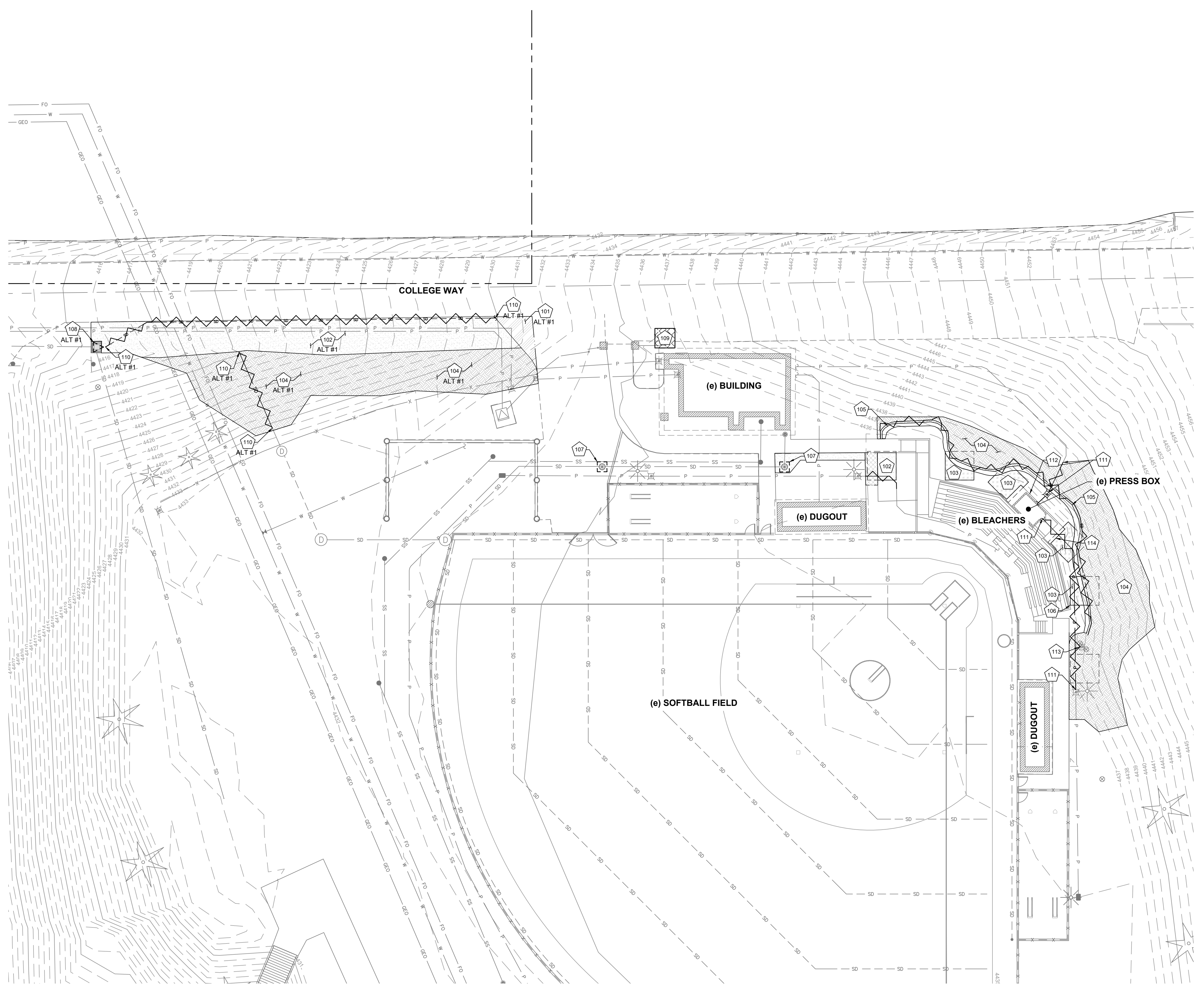

ONE INCH EQUALS FULL SCALE

1 SITE DEMOLITION PLAN
C1.00

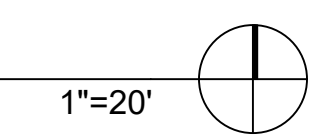
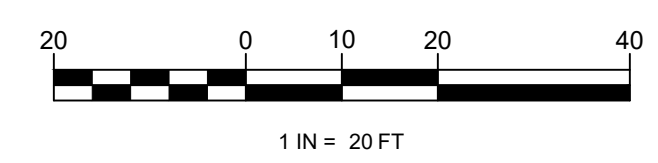

DESCRIPTION	DATE

PROJECT NO: K-6428-25
DESIGNED: MEG, CMW
REVIEWED: MKW
DATE: 03-11-2026

SITE DEMOLITION PLAN

C1.00

BID & PERMIT SET | NOT ISSUED FOR CONSTRUCTION



900 Klamath Avenue
Klamath Falls, OR 97601
541.884.7421

OREGON TECH
3201 CAMPUS DR.
KLAMATH FALLS, OR 97601

STILWELL
STADIUM
CANOPY



LEGEND

HATCHES & LINE TYPES:

- CONCRETE SIDEWALK
- ASPHALT PAVING
- DECOMPOSED GRANITE SURFACING
- LANDSCAPING REPAIR
- GRAVEL SURFACING
- ECOBLOCK WALL
- SEGMENTAL BLOCK WALL
- CANOPY OVERHANG
- CONCRETE FOOTING
- 4440 (N) SURFACE CONTOUR - MAJOR
- 4439 (N) SURFACE CONTOUR - MINOR
- 4440 (e) SURFACE CONTOUR - MAJOR
- 4439 (e) SURFACE CONTOUR - MINOR
- SS STORM SEWER (Ø VARIES)
- FD FOOTING DRAIN
- PWR BURIED POWER

SYMBOLS:

- PARKING BUMPER
- ROOF DOWNSPOUT
- STORM DRAIN CLEANOUT
- BUBBLE UP

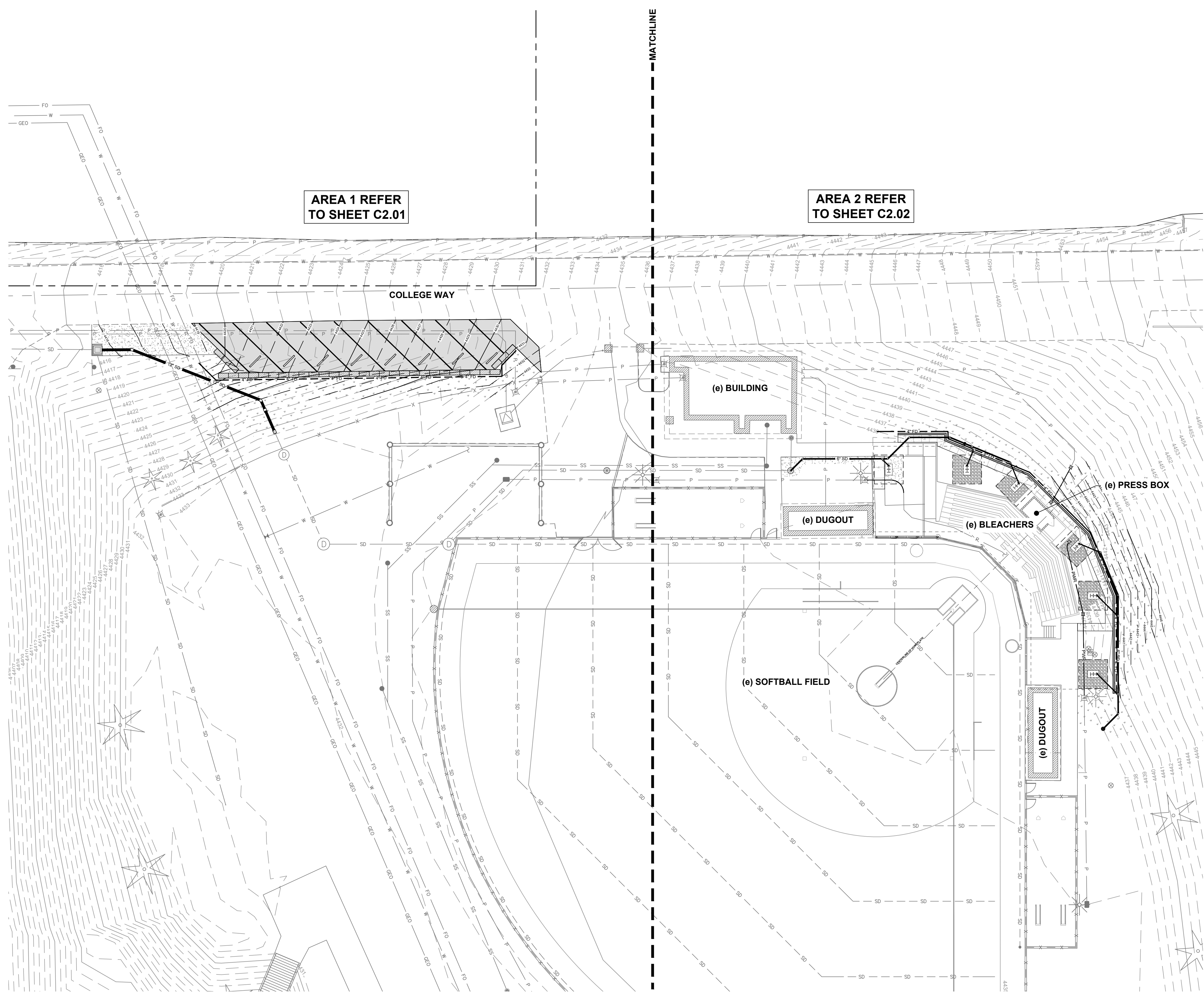

ONE INCH EQUALS FULL SCALE

1 OVERALL SITE PLAN
C2.00

1"=20'

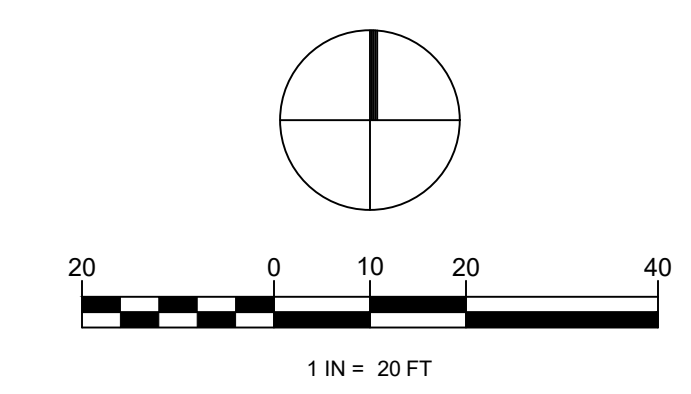

DESCRIPTION	DATE

PROJECT NO: K-6428-25
 DESIGNED: MEG, CMW
 REVIEWED: MKW
 DATE: 03-11-2026

OVERALL SITE PLAN

C2.00

BID & PERMIT SET | NOT ISSUED FOR CONSTRUCTION



900 Klamath Avenue
Klamath Falls, OR 97601
541.884.7421

OREGON TECH
3201 CAMPUS DR.
KLAMATH FALLS, OR 97601

STILWELL
STADIUM
CANOPY

Oregon TECH
Oregon Institute of Technology

LEGEND

HATCHES & LINE TYPES:

- ASPHALT PAVING
- LANDSCAPING REPAIR
- GRAVEL SURFACING
- ECOBLOCK WALL
- (N) SURFACE CONTOUR - MAJOR
- (N) SURFACE CONTOUR - MINOR
- (E) SURFACE CONTOUR - MAJOR
- (E) SURFACE CONTOUR - MINOR
- STORM SEWER (Ø VARIES)
- FOOTING DRAIN

SYMBOLS:

- PARKING BUMPER
- GRADE SPOT ELEVATION
- GRADING SLOPE
- HORIZONTAL CONTROL POINT

ABBREVIATIONS

- ACP ASPHALT PAVEMENT
- M/E MATCH EXISTING
- TOW TOP OF WALL

CIVIL SITE, GRADING, AND UTILITY NOTES:

TRANSITION BETWEEN NEW AND EXISTING ASPHALT SHALL BE FLUSH AND FREE FROM ABRUPT CHANGES IN HEIGHT.

- NOTES:**
- STANDARD DUTY ASPHALT PER 2/C3.00.
 - ECOBLOCK RETAINING WALL (MAX RETAINED HEIGHT, 3-FT) PER 8/C3.00.
 - GRAVEL BASE AGGREGATE, 12" DEPTH MINIMUM, UNDERLAID WITH NON-WOVEN GEOTEXTILE SUPPORT FABRIC.
 - PERMANENT SEEDING LANDSCAPE REPAIR.
 - 4" SOLID WHITE STRIPING PER 'W' ON ODOT STANDARD DRAWING TM500 ANGLED 45° FROM PARALLEL, TYPICAL.
 - CONCRETE PARKING BUMPER PER 4/C3.00, TYPICAL.
 - STORM PIPE IN TRENCH PER 5/C3.00.
 - CONNECT TO EXISTING 'HDPE' PIPE USING FLEXIBLE FERRO COUPLER OR PRE-MANUFACTURED ELBOW FITTING.
 - CONNECT TO EXISTING DITCH INLET WITH 'KOR-N-SEAL' 'S106-16AW' BOOT.
 - PIPE OUTFALL PER 10/C3.01.

HORIZONTAL CONTROL POINT TABLE

POINT #	NORTHING	EASTING
1	185532.876	253369.737
2	185534.492	253496.488
3	185524.519	253497.373
4	185514.571	253388.539
5	185513.048	253380.409
6	185514.525	253490.435
7	185472.578	253646.980
8	185488.575	253669.201
9	185484.151	253666.205
10	185472.578	253678.146
11	185472.510	253702.276
12	185466.653	253696.094
13	185467.061	253702.689
14	185449.383	253720.365
15	185448.888	253725.940
16	185442.611	253720.136
17	185424.663	253726.061
18	185418.913	253733.087
19	185393.497	253726.061
20	185385.803	253736.116

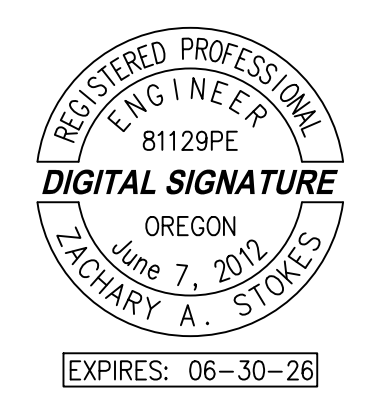

DESCRIPTION	DATE

PROJECT NO: K-6428-25
 DESIGNED: MEG, CMW
 REVIEWED: MKW
 DATE: 03-11-2026

PARKING IMPROVEMENTS
 ALT #1

C2.01

BID & PERMIT SET | NOT ISSUED FOR CONSTRUCTION

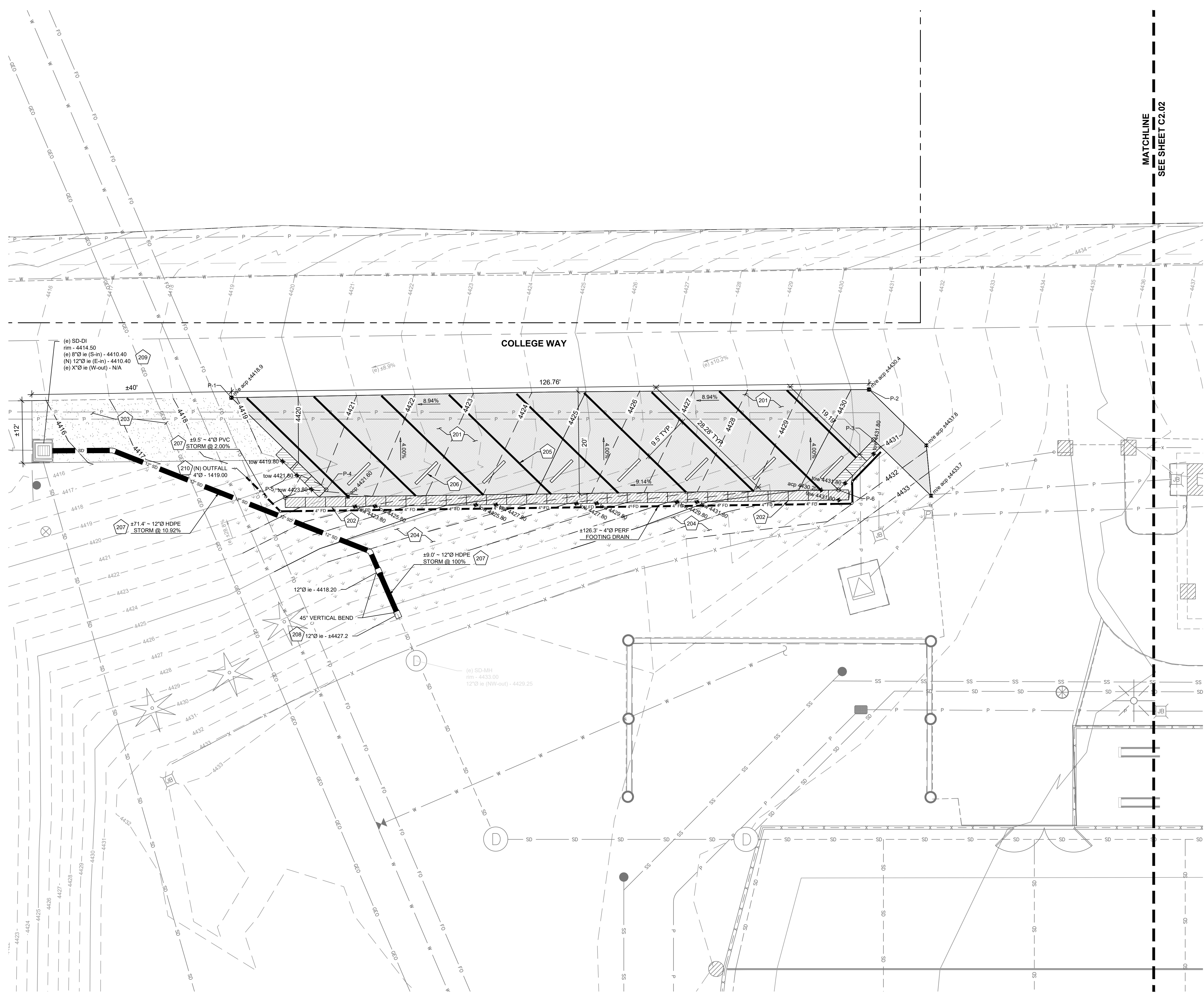

MATCHLINE
SEE SHEET C2.02

ONE INCH EQUALS FULL SCALE

1 PARKING IMPROVEMENTS

C2.01

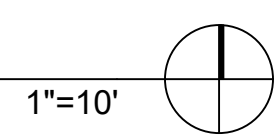
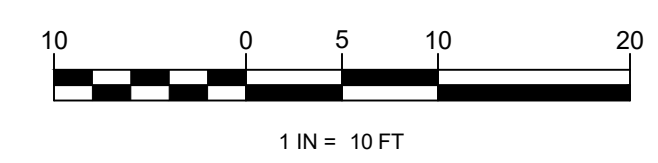

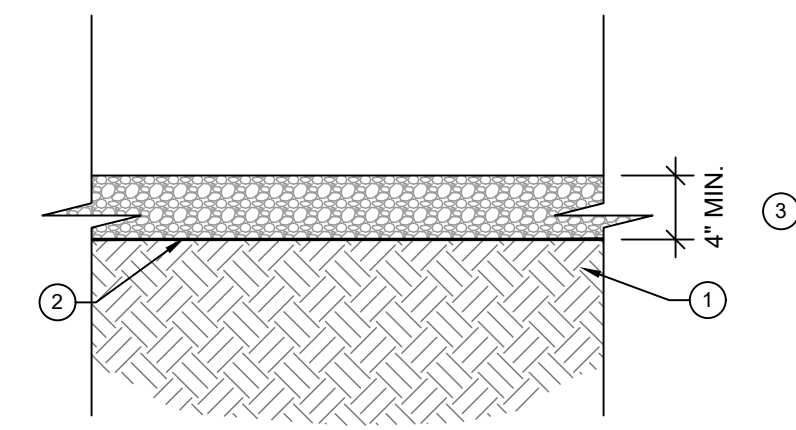
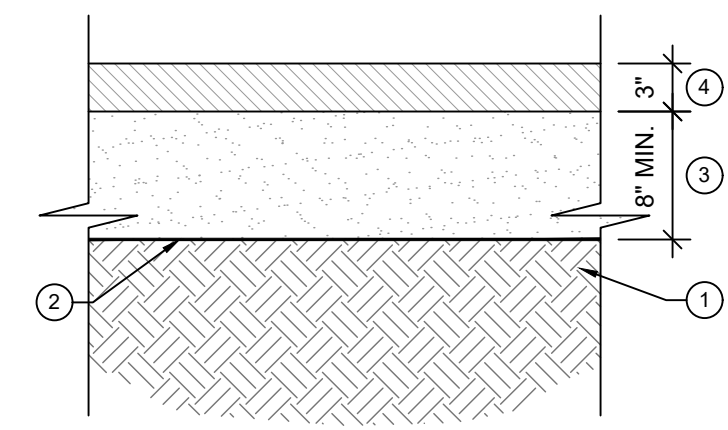
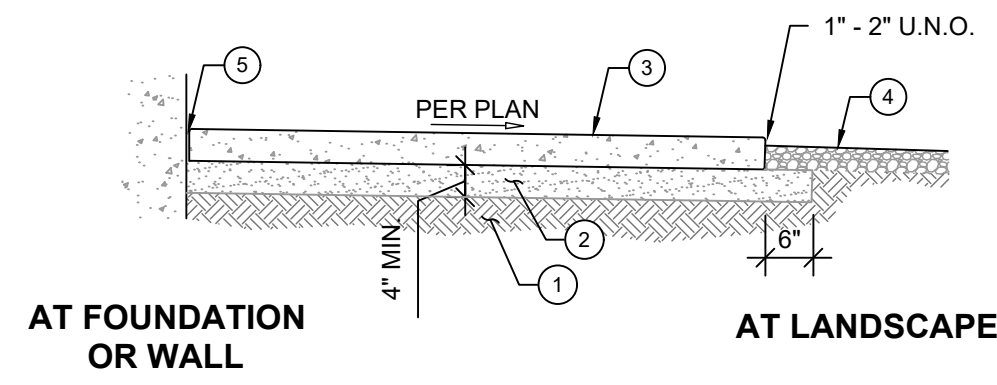
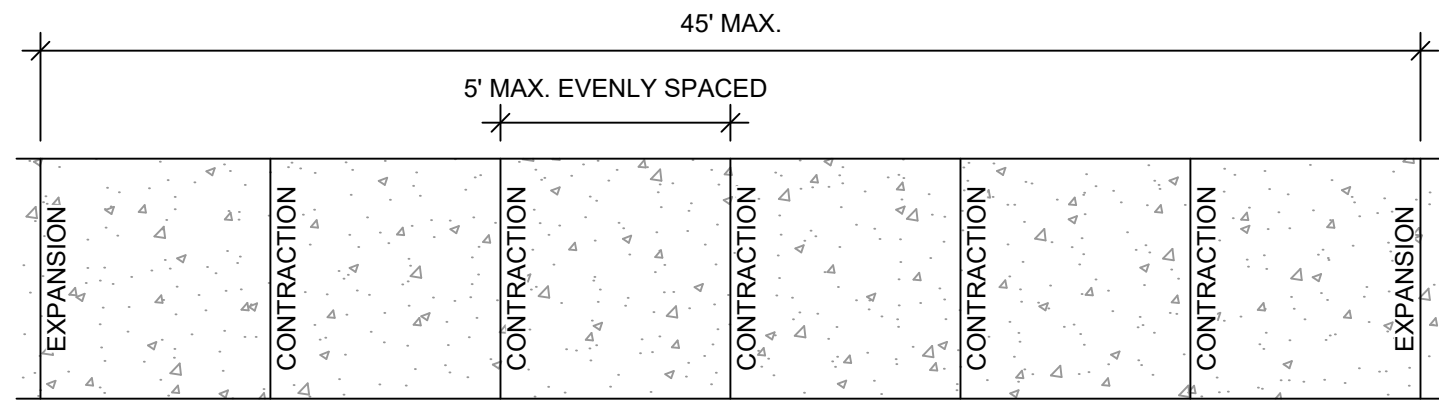

- KEY NOTES:**
- APPROVED SUBGRADE.
 - 3/4" MINUS COMPACTED AGGREGATE PLACED IN MAX. 8" LOOSE LIFTS, COMPACTED TO 95% OF ASTM D698.
 - UNREINFORCED CONCRETE SIDEWALK, 4" THICK COMMERCIAL GRADE CONCRETE.
 - LANDSCAPE PER PLAN.
 - EXPANSION JOINT.
- NOTES:**
- SIDEWALK PANELS TO BE GENERALLY SQUARE.
 - SIDEWALK PANELS TO HAVE BROOMED FINISH.
 - PROVIDE EXPANSION JOINTS AROUND POLES, BOXES, AND OTHER FIXTURES.

- KEY NOTES:**
- APPROVED SUBGRADE.
 - WOVEN GEOTEXTILE SUPPORT FABRIC.
 - 3/4" MINUS COMPACTED AGGREGATE BASE ROCK. PLACE IN MAX. 8" LOOSE LIFTS COMPACTED TO 95% OF ASTM D698.
 - 3" OF LEVEL 2, 1/2" DENSE MIX COMPACTED ASPHALT CONCRETE PAVEMENT WITH PG 64-28 BINDER PLACED IN ONE LIFT.

- KEY NOTES:**
- APPROVED SUBGRADE.
 - WOVEN GEOTEXTILE SUPPORT FABRIC.
 - DECOMPOSED GRANITE FROM STOCKPILE.

1 4" THICK SIDEWALK C3.00 NTS

2 ASPHALT PAVEMENT SECTION C3.00 1" = 1'

3 DECOMPOSED GRANITE SURFACING SECTION C3.00 1" = 1'

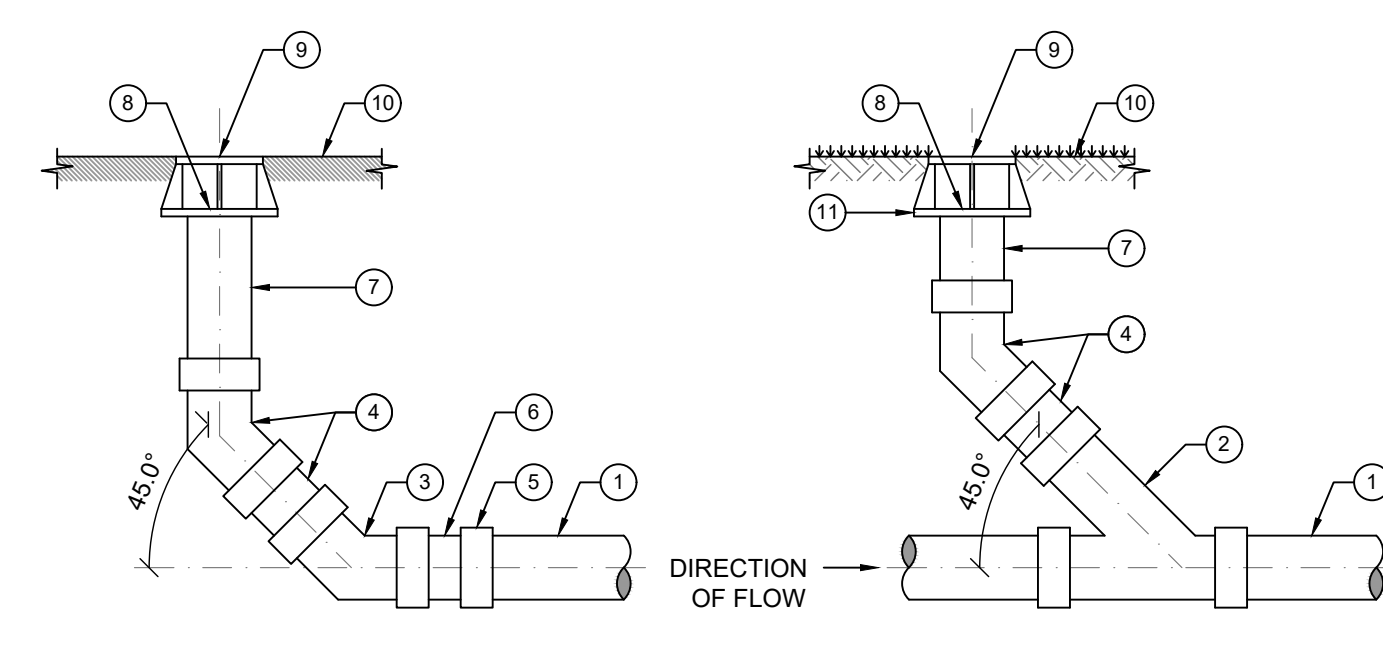
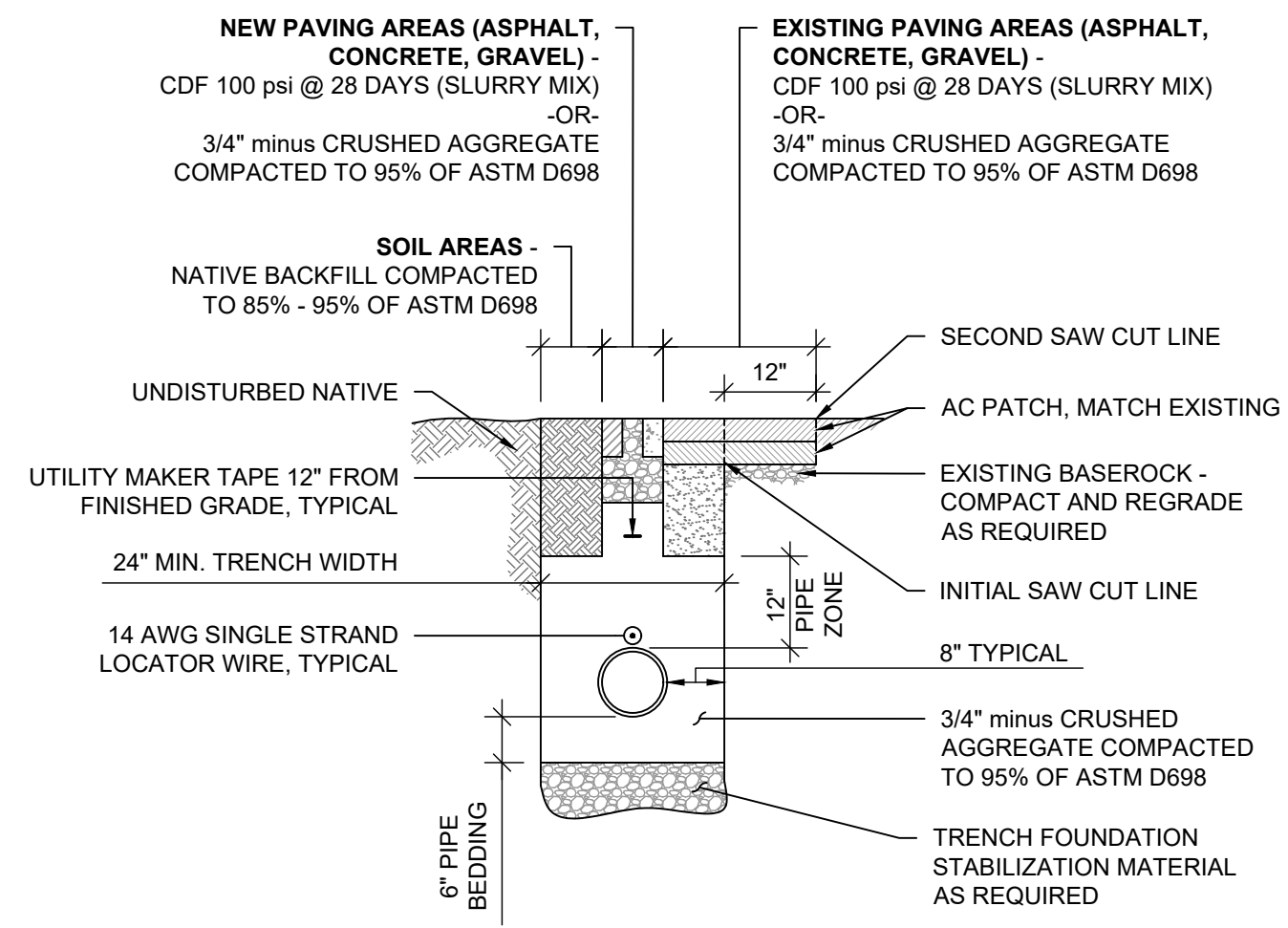
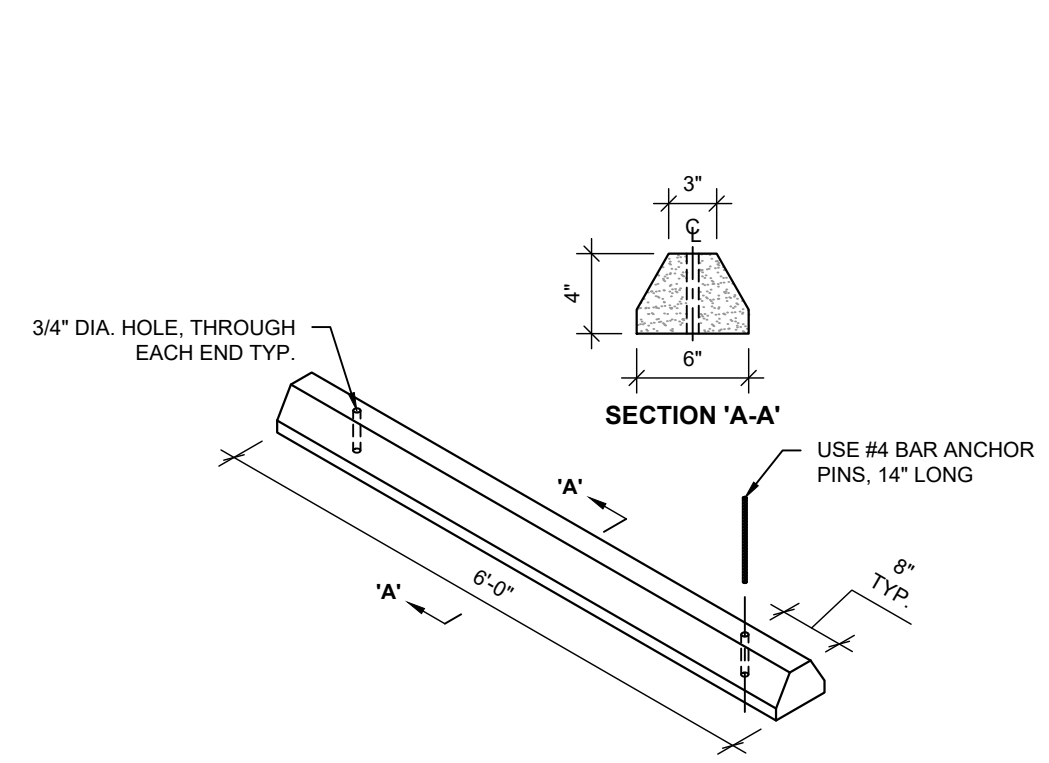

- KEY NOTES:**
- MAIN LINE PER PLAN
 - WYE
 - 45° BEND
 - SPOOL AND 45° BEND OR BELL x SPIGOT 45° BEND
 - ECCENTRIC REDUCER AS NECESSARY
 - SPOOL AS NECESSARY
 - CLEANOUT RISER. 4"Ø FOR 4"Ø LINE, 6"Ø FOR 6"Ø AND LARGER LINE
 - FINISH GRADE PER PLAN
 - IF LOCATED WITHIN LANDSCAPE OR OPEN GROUND AREAS PROVIDE 24"Ø 4" THICK CONCRETE COLLARE AROUND CLEANOUT RING AND COVER.
- NOTES:**
- ALL FITTING, RISER, AND SPOOL MATERIALS TO MATCH MAIN LINE, UNLESS NOTED OTHERWISE.

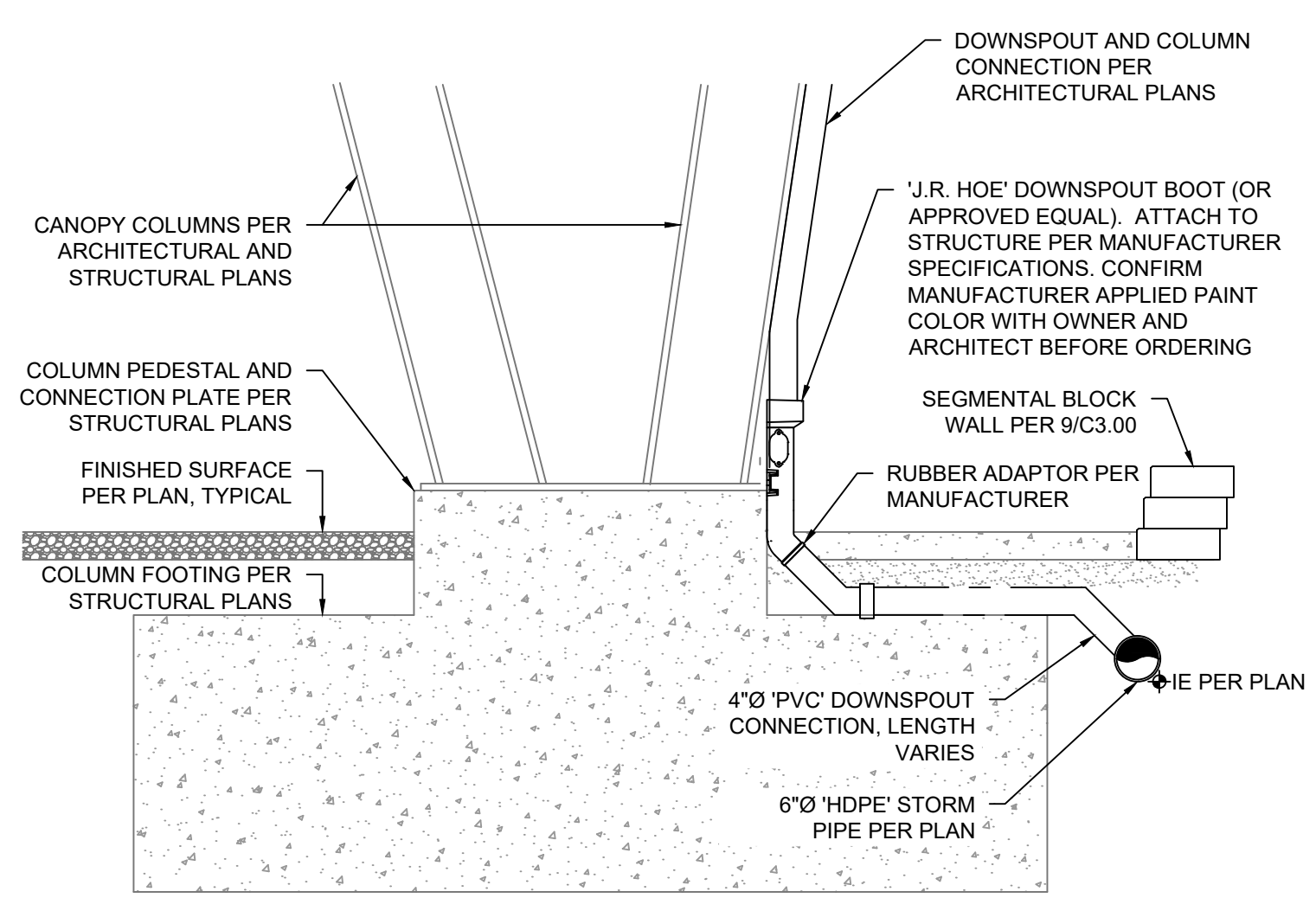

4 CONCRETE PARKING BUMPER C3.00 NTS

5 TYPICAL PRIVATE WET UTILITY TRENCH SECTION C3.00 1/2" = 1'

6 TYPICAL PRIVATE CLEANOUT TO GRADE C3.00 NTS

7 TYPICAL DOWNSPOUT CONNECTION C3.00 NTS

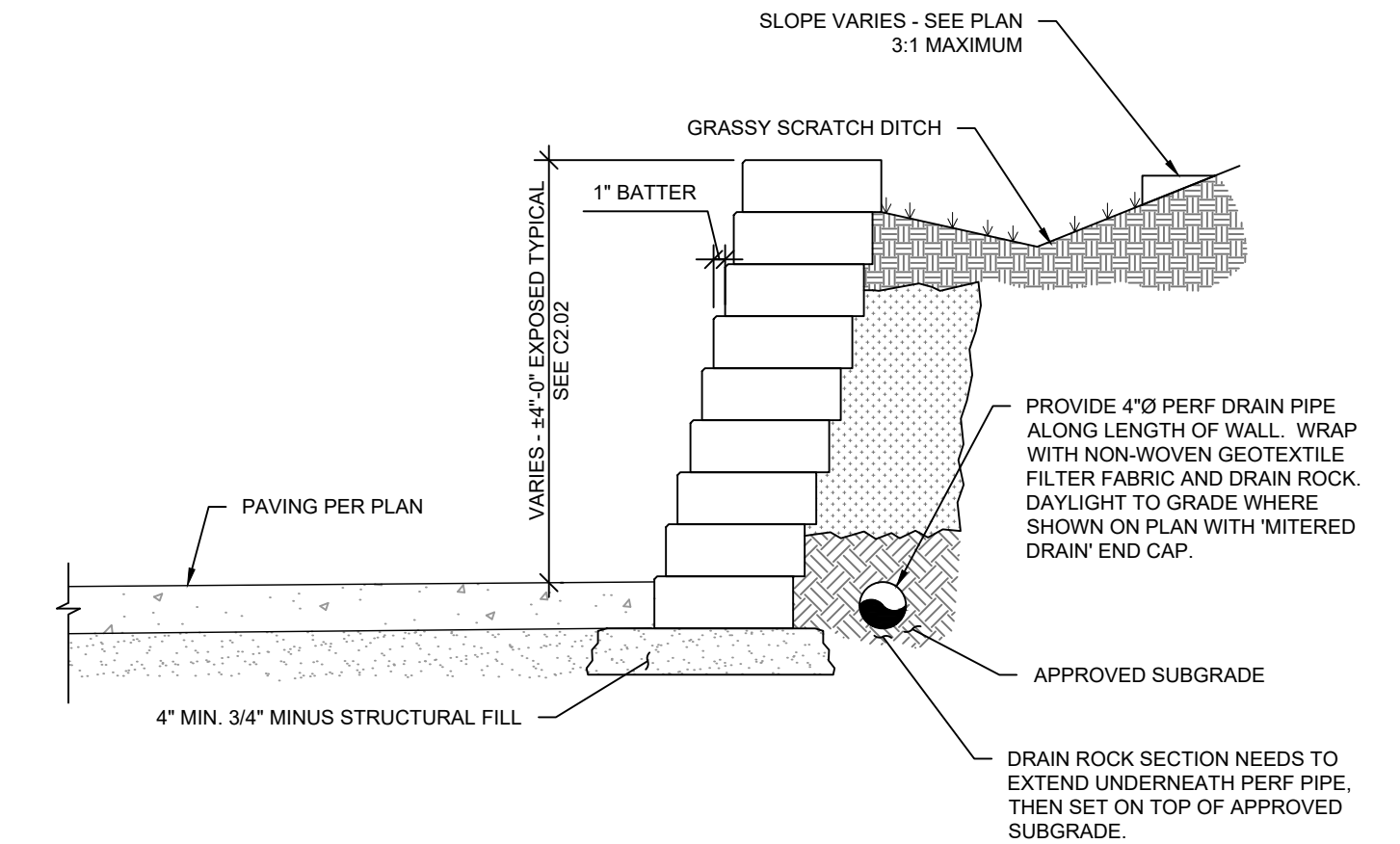
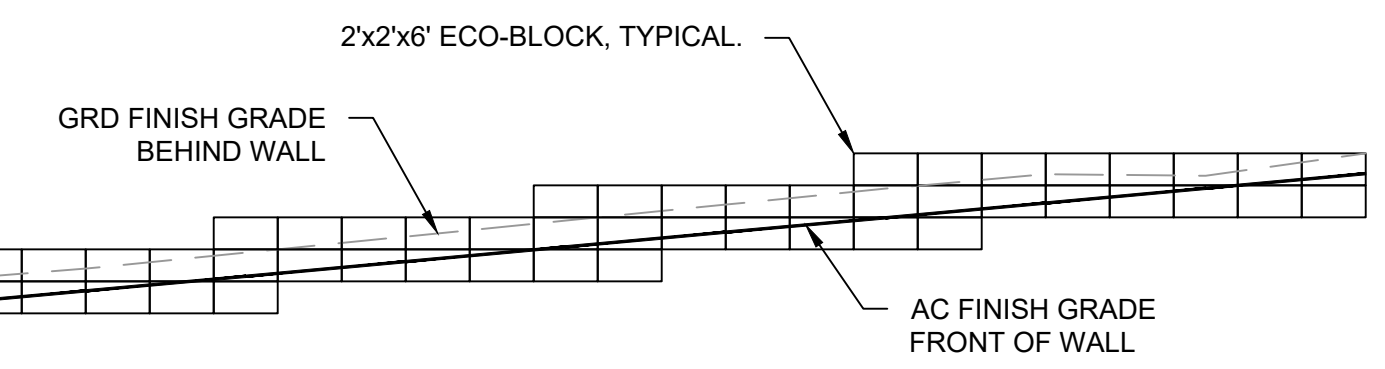
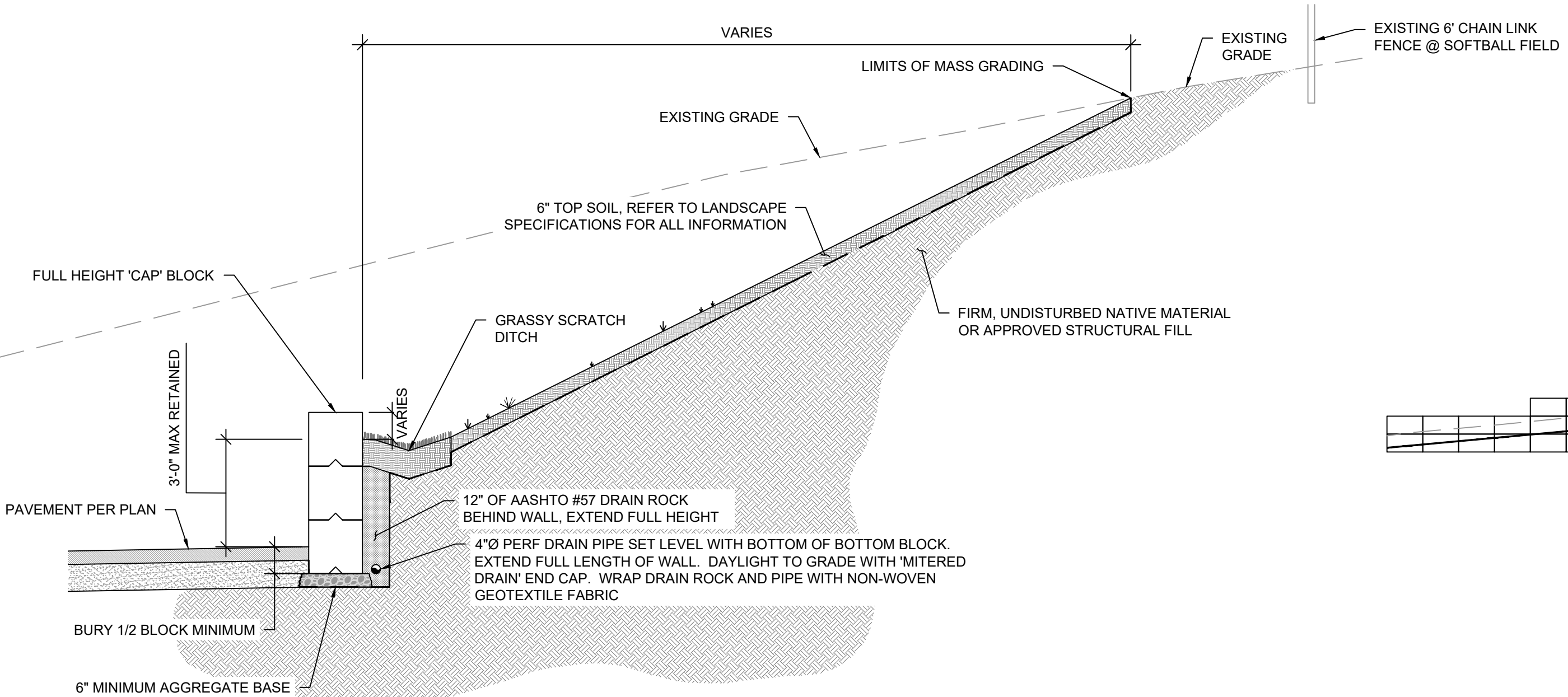

8 ECO-BLOCK GRAVITY RETAINING WALL C3.00 1/4" = 1'-0"

9 UNREINFORCED SEGMENTAL BLOCK WALL SECTION C3.00 3/4" = 1'



OREGON TECH
3201 CAMPUS DR.
KLAMATH FALLS, OR 97601

STILWELL
STADIUM
CANOPY

Oregon TECH
Oregon Institute of Technology



DESCRIPTION	DATE

PROJECT NO: K-6428-25
DESIGNED: MEG, CMW
REVIEWED: MKW
DATE: 03-11-2026

CIVIL DETAILS

C3.00

ONE INCH EQUALS FULL SCALE

BID & PERMIT SET NOT ISSUED FOR CONSTRUCTION



900 Klamath Avenue
Klamath Falls, OR 97601
541.884.7421

OREGON TECH
3201 CAMPUS DR.
KLAMATH FALLS, OR 97601

**STILWELL
STADIUM
CANOPY**

Oregon TECH
Oregon Institute of Technology

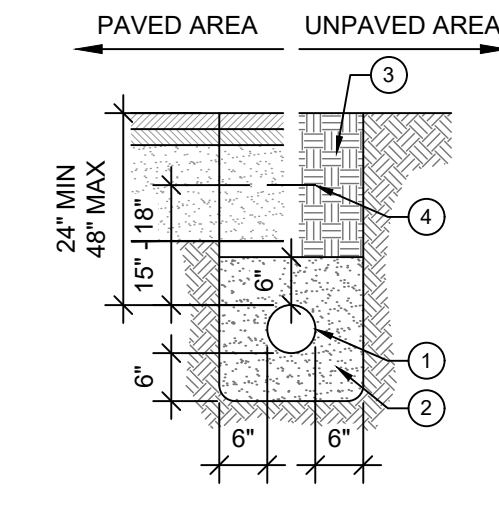
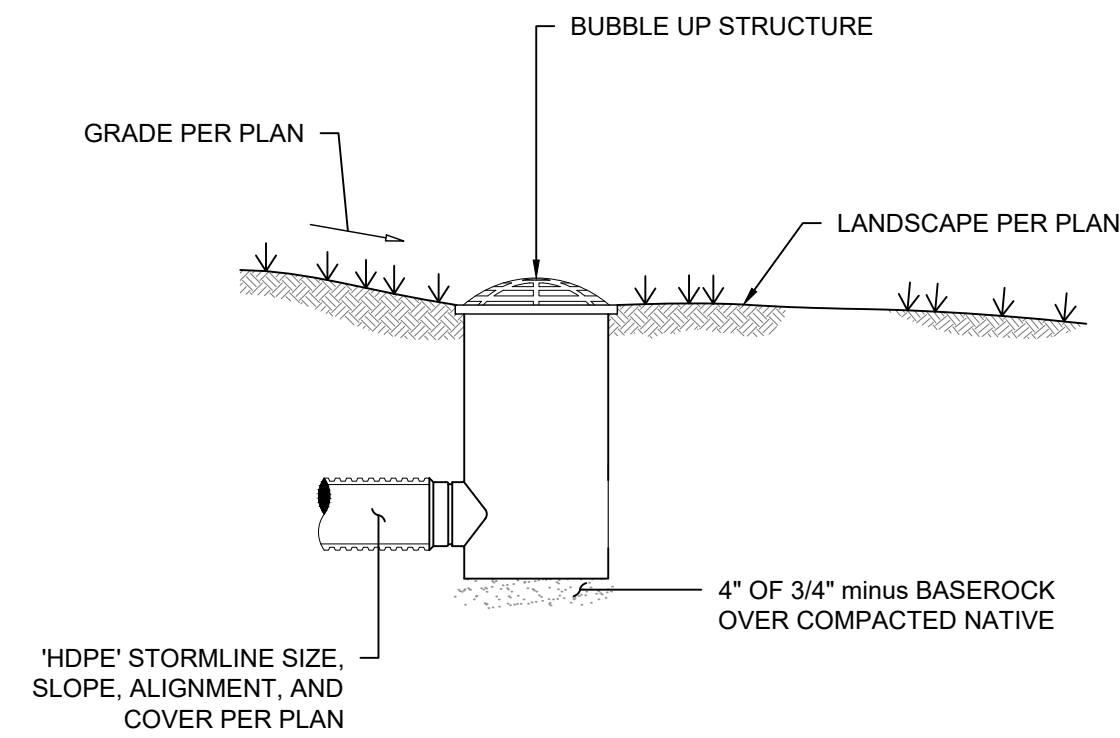
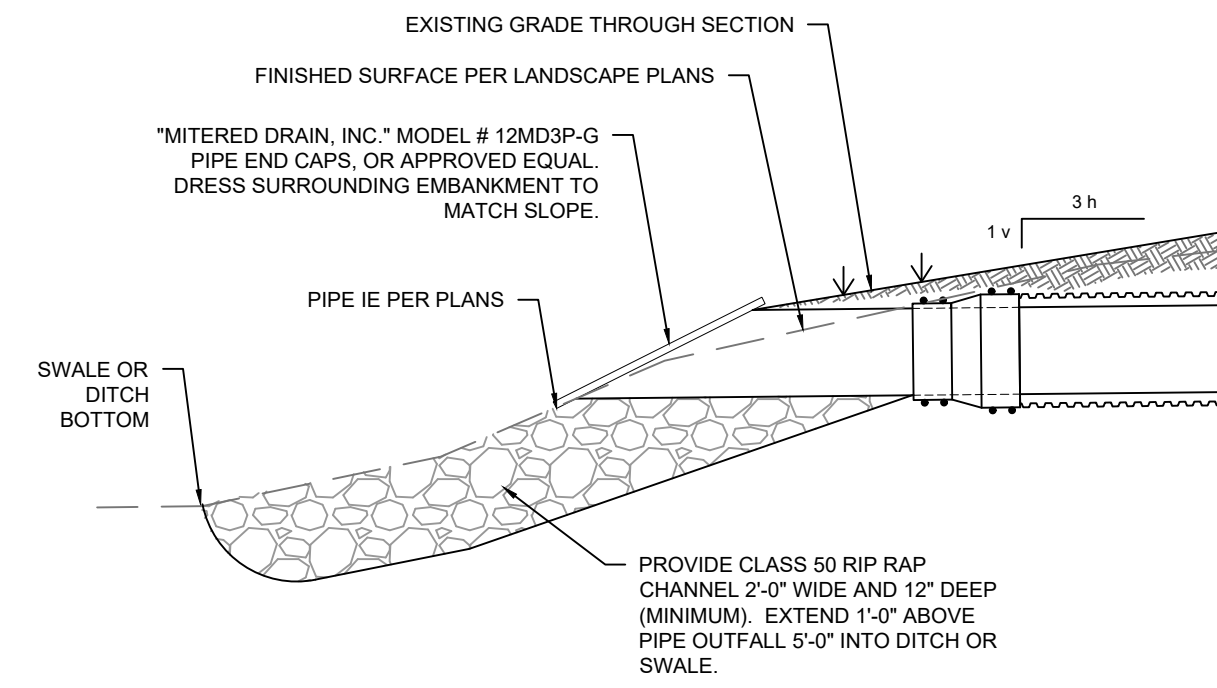

- KEY NOTES:**
1. SECONDARY POWER OR DATA/COMMUNICATIONS CONDUIT.
 2. PIPE ZONE: 3/4" MINUS COMPACTED CRUSHED ROCK.
 3. COMPACTED RECLAIMED NATIVE BACKFILL.
 4. WARNING TAPE
POWER: 6" WIDE, RED, READING 'CAUTION BURIED ELECTRIC LINE BELOW'.
COMMUNICATIONS: 6" WIDE, ORANGE, READING 'CAUTION BURIED COMMUNICATIONS LINE
BELOW'.
 5. PAVEMENT SECTION PER PLAN.

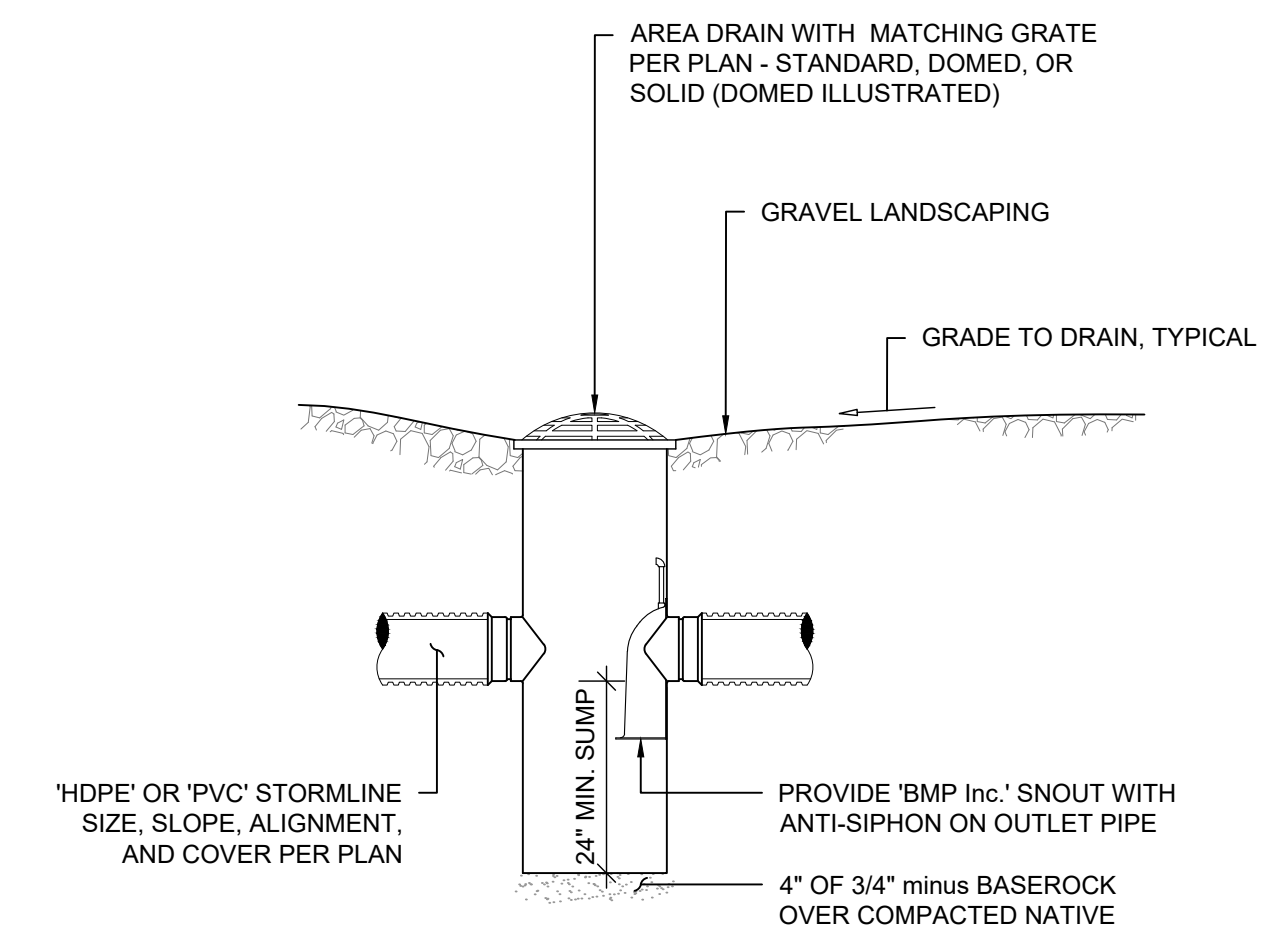

10 PIPE OUTFALL
C3.01 1/2" = 1'

11 BUBBLER UP STRUCTURE
C3.01 NTS

12 POWER/DATA CONDUIT TRENCH
C3.01 NTS

13 AREA DRAIN
C3.01 NTS

ONE INCH EQUALS FULL SCALE



DESCRIPTION	DATE

PROJECT NO: K-6428-25
DESIGNED: MEG, CMW
REVIEWED: MKW
DATE: 03-11-2026

CIVIL DETAILS

C3.01

BID & PERMIT SET | NOT ISSUED FOR CONSTRUCTION

GEOTEXTILE/WIRE MESH/AGGREGATE - TYPE 2
NOT TO SCALE

PREFABRICATED FILTER INSERT - TYPE 3
NOT TO SCALE

SOD PROTECTION - TYPE 6
NOT TO SCALE

COMPOST FILTER SOCK OR WATTLE - TYPE 7
NOT TO SCALE

CURB INLET SEDIMENT DAM - TYPE 10
NOT TO SCALE

WATTLE BARRIER WITH FILTER INSERT - TYPE 11
NOT TO SCALE

AREA DRAIN PLAN
NOT TO SCALE

AREA DRAIN PERSPECTIVE VIEW
NOT TO SCALE

CURB INLET PERSPECTIVE VIEW
NOT TO SCALE

NOTES:
Type 2 - Geotextile/wire mesh/aggregate. Place the wire mesh over the grate. Place sediment fence geotextile over the wire mesh and perimeter area around structure. Install aggregate over the geotextile fabric.
Type 3 - Prefabricated filter inserts. Install prefabricated filter inserts according to the plans, special provisions, and manufacturer recommendations. Prefabricated inserts with provisions for overflow are allowed only when accompanied by additional BMPs to prevent the potential of sediments entering project storm systems. Field fabricated inserts are not allowed.
Type 7 - Compost filter sock. Drive 2"x2" wooden stakes a minimum of 8" into ground and flush with the top of the sock. Adjust, replace or modify the inlet protection as needed to prevent sediment laden water from entering the catch basin.
Type 10 - Curb inlet sediment dam. Fit curb inlet sediment dam snugly into inlet mouth. Curb inlet sediment dam is required for use with inlet filter insert where an in-grade inlet grate and curb inlet are combined at a catch basin.
Type 11 - Wattle barrier with filter insert. Install prefabricated filter inserts per Type 3 detail. Install wattles over opening and 36" to each side of opening tight against curb. Adjust wattle to force storm water to flow through filter insert or wattle prior to leaving the site. Adjust, replace or modify the inlet protection as needed to prevent sediment laden water from entering the catch basin.

Effective Date: December 1, 2025 – May 31, 2026

PLAN DITCH INLET

PLAN AREA DRAIN

SECTION A-A DITCH INLET

PLAN CATCH BASIN

BIOFILTER BAGS - TYPE 4
NOT TO SCALE

NOTES:
1. Stake biofilter bags with 2"x2"x36" wooden stakes, and use a minimum 2 stakes per bag. Drive stakes a minimum of 6" into the ground and flush with the top of the bags.
2. Omit stakes when bags are placed on pavement surface.
3. Overlap all bag joints 6".
4. Biofilter bags used on active roadways are easily displaced and made ineffective if struck by vehicles. If struck by a cyclic, falls with injury could result. On active roadways alternative inlet protection should be considered.

Effective Date: June 1, 2025 – November 30, 2025

PLAN

SECTION A-A

STAPLE DETAIL
NOT TO SCALE

CONCRETE TRUCK WASH OUT FACILITY
NOT TO SCALE

CONCRETE TRUCK WASH OUT
NOT TO SCALE

NOTES:
The selection and use of this Standard Drawing, while designed in accordance with generally accepted engineering principles and practices, is the sole responsibility of the user and should not be used without first consulting a Registered Professional Engineer.

Effective Date: December 1, 2025 – May 31, 2026

4" WHITE LINE

8" WHITE LINE

4" YELLOW LINE

CHEVRON BARS
1" WHITE BARS AT 20" SPACING

TRANSVERSE MEDIAN BARS
1" YELLOW BARS AT 20" SPACING

4" WHITE BROKEN LINE

4" YELLOW BROKEN LINE

4" WHITE DOTTED LINE
For lane extensions

8" WHITE DOTTED LINE
For lane extensions and bike lane extensions

4" YELLOW DOTTED LINE
For lane extensions

4" WHITE DOTTED LANE LINE
For lane lines in acceleration/deceleration lanes

8" WHITE DOTTED LANE LINE
For lane lines in drop lanes

NO-PASS RIGHT 4" YELLOW LINES

NO-PASS LEFT 4" YELLOW LINES

TWO-WAY LEFT TURN 4" YELLOW LINES

TRANSVERSE MEDIAN BARS
1" YELLOW BARS AT 40" SPACING
For use at painted medians where distance between left turn relays exceeds 200'

DOUBLE NO-PASS TWO 4" YELLOW LINES

NARROW DOUBLE NO-PASS TWO 4" YELLOW LINES

NARROW DOUBLE NO-LANE CHANGE TWO 4" WHITE LINES

DISABLED PARKING DETAIL (white)

YIELD LINE (white)

BICYCLE YIELD LINE (white)

TRANSVERSE SHOULDER BARS
1" WHITE BARS AT 20" SPACING

PAVEMENT MARKING STANDARD DETAIL BLOCKS
NOT TO SCALE

NOTES:
The selection and use of this Standard Drawing, while designed in accordance with generally accepted engineering principles and practices, is the sole responsibility of the user and should not be used without first consulting a Registered Professional Engineer.

Effective Date: June 1, 2025 – November 30, 2025

ONE INCH EQUALS FULL SCALE 3/9/2026 3:16:20 PM

#4 ROOF/CEILING ASSEMBLIES SCALE: 1" = 1'-0"

INDICATES ASSEMBLY FOOTNOTE
INDICATES ASSEMBLY TYPE

GENERAL ASSEMBLY NOTES:
A. NONE

ASSEMBLY FOOTNOTES:
1. NONE

R1 | NON-RATED |

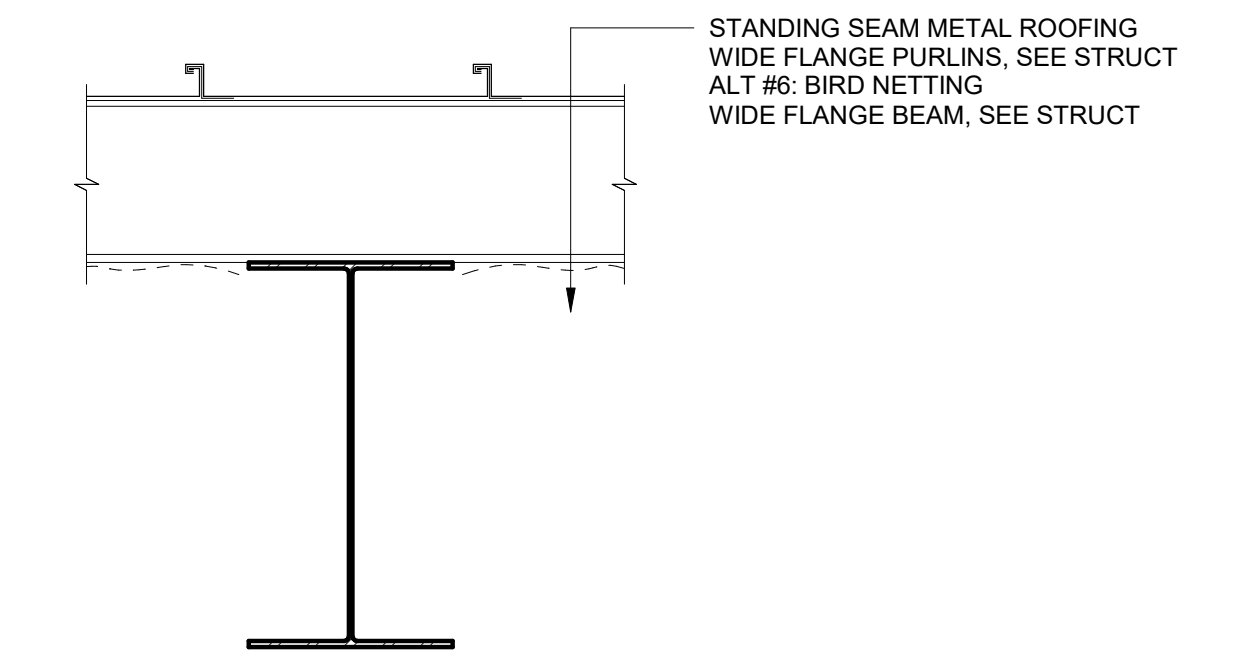

OREGON TECH
3201 CAMPUS DR.
KLAMATH FALLS, OR 97601

**STILWELL
STADIUM
CANOPY**



ROOFING					
FINISH CODE	MATERIAL	MANUFACTURER	STYLE / COLOR	SIZE / THICKNESS	INSTALLATION NOTES
SS	STANDING SEAM METAL ROOFING	TAYLOR METAL	MS-200 / STERLING GREY	18" COVERAGE / 24 GA.	90° SEAMS

ALT #4 - PAINT FINISHES					
FINISH CODE	MATERIAL	MANUFACTURER	STYLE / COLOR	FINISH SHEEN	INSTALLATION NOTES
PT1	PAINT	SHERWIN WILLIAMS	MATCH (E), SEE DRAW-DOWN BELOW	SATIN	SEE DRAW-DOWN BELOW

SHERWIN-WILLIAMS 8051 01/09/19
541-884-7784 Order# 0113469
INTERIOR ARCHITECTURAL
COLOR TO GO LATEX
SATIN STANDALONE
COMP(F003) 26250 26250
CUSTOM SHER-COLOR MATCH

CCE*COLORANT 02 32 64 128
B1-Black - 43 1 -
G2-New Green - 2 - 1
Y3-Deep Gold - 10 - -

QUART EXTRA WHITE
A91W00451 650955941



△	DATE:	Description

PROJECT NO. K-6428-25
DRAWN: JMH
CHECKED: MJC
DATE: 03-11-2026

ASSEMBLIES &
SCHEDULES

A0.10

BID AND PERMIT SET | NOT ISSUED FOR CONSTRUCTION

CODE SUMMARY

LIFE SAFETY NARRATIVE
 THE NEW CANOPY OVER THE EXISTING SOFTBALL FIELD BLEACHERS IS AN OPEN AIR STRUCTURE INTENDED TO SHIELD SPECTATORS FROM THE SUN AND RAIN. PER THE 2019 RECORD DRAWINGS, THE EXISTING ADA ACCESSIBLE BLEACHERS SEAT APPROXIMATELY 284 OCCUPANTS. THE PROPOSED CANOPY DOES NOT HAVE ANY IMPACT ON THE EXISTING OCCUPANCY, OCCUPANT LOADING, EGRESSING OR ACCESSIBILITY.

APPLICABLE CODES

BUILDING CODE: 2022 OSSC
 ELECTRICAL CODE: 2023 OESC
 FIRE CODE: 2022 OFC

BUILDING DATA:

CONSTRUCTION TYPE: IIB
 OCCUPANCIES: A-5
 ALLOWABLE BUILDING AREA: UNLIMITED
 PROPOSED BUILDING AREA: 4,564 SF
 ALLOWABLE BUILDING HEIGHT: 55'-0"
 PROPOSED BUILDING AREA: 27'-11" ±
 ALLOWABLE NUMBER OF STORIES: UNLIMITED
 FIRE SPRINKLER: NO
 FIRE ALARM: NO

CH. 9 - FIRE PROTECTION AND LIFE SAFETY SYSTEMS

903.2.1.5 AN AUTOMATIC SPRINKLER SYSTEM SHALL BE PROVIDED FOR ALL ENCLOSED GROUP A-5 ACCESSORY USE AREAS IN EXCESS OF 1,000 SF
AN AUTOMATIC SPRINKLER SYSTEM IS NOT REQUIRED AS THE PROPOSED CANOPY IS AN OPEN AIR STRUCTURE AND DOES NOT ENCLOSE THE GROUP A-5 OCCUPANTS
 907.2.1 A MANUAL FIRE ALARM SYSTEM THAT ACTIVATES THE OCCUPANT NOTIFICATION SYSTEM IN ACCORDANCE WITH SECTION 907.5 SHALL BE INSTALLED IN GROUP A OCCUPANCIES WHERE THE OCCUPANT LOAD DUE TO THE ASSEMBLY OCCUPANCY IS 300 OR MORE
A MANUAL FIRE ALARM SYSTEM IS NOT REQUIRED AS THE OCCUPANT LOAD OF THE EXISTING BLEACHERS IS LESS THAN 300

FLOOR PLAN GENERAL NOTES

- A. VERIFY ALL DIMENSIONS AND NOTIFY PROJECT TEAM IF DISCREPANCIES OCCUR.
- B. DIMENSIONS SHOWN TO CENTER OF FRAMING, UNO
- C. G.C. TO COORDINATE INSTALLATION OF ALL UTILITIES W/ RESPECTIVE SUPPLIERS/SUBCONTRACTORS PRIOR TO CONSTRUCTION, TYPICAL.
- D. ALL ELECTRICAL TO BE DESIGN BUILD PER APPLICABLE CODES.

LEGEND

- ROOF OUTLINE ABOVE
- (E) CONCRETE SLAB
- (N) CONCRETE SLAB, SEE CIVIL

KEYNOTES

- 1 RETAINING WALL, SEE CIVIL
- 2 (E) LIGHT POLE
- 3 CANOPY FOOTING, SEE STRUCT
- 4 (E) PRESS BOX
- 5 CONCRETE PEDESTAL, SEE STRUCT
- 6 (E) ACCESSIBLE RAMP



900 Klamath Avenue
 Klamath Falls, OR 97601
 541.884.7421

OREGON TECH
 3201 CAMPUS DR.
 KLAMATH FALLS, OR 97601

**STILWELL
 STADIUM
 CANOPY**

Oregon TECH
 Oregon Institute of Technology

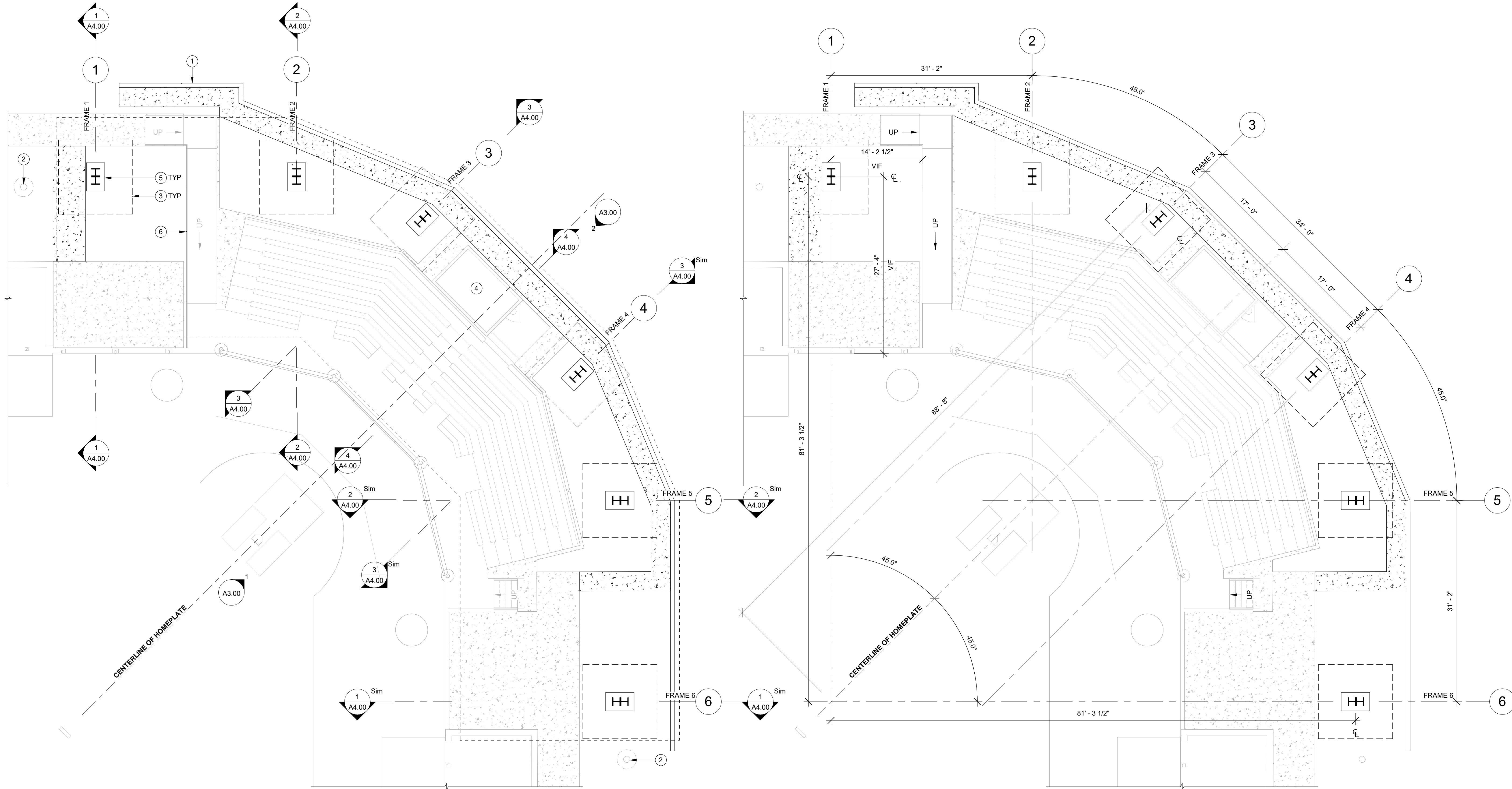

1 FLOOR PLAN
 A1.00 1/8" = 1'-0"

2 DIMENSIONING PLAN
 A1.00 1/8" = 1'-0"

3/9/2026 3:16:22 PM

ONE INCH EQUALS FULL SCALE

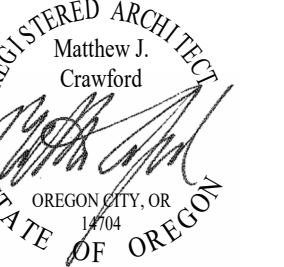

DATE:	Description

PROJECT NO. K-6428-25
 DRAWN: JMH
 CHECKED: MJC
 DATE: 03-11-2026

FLOOR &
 DIMENSIONING
 PLANS

A1.00

BID AND PERMIT SET | NOT ISSUED FOR CONSTRUCTION

ROOF PLAN GENERAL NOTES

- A. ALL WORK AND MATERIALS SHALL CONFORM TO ALL APPLICABLE STATE AND LOCAL REGULATIONS, STANDARDS AND MFR. SPECIFICATIONS AND THE OSSC. CONTACT PROJECT TEAM FOR DIRECTIVE IN THE EVENT OF CONFLICTING STANDARDS AND SPECS.
- B. VERIFY ALL DIMENSIONS, ELEVATIONS AND LOCATIONS PRIOR TO CONSTRUCTION. NOTIFY PROJECT TEAM OF ANY DISCREPANCIES. DIMENSIONS ON THIS PLAN ARE NOT SUITABLE FOR MATERIAL ORDERING USE. CONTRACTOR MUST FIELD VERIFY ALL DIMENSIONS PRIOR TO BIDDING AND ORDERING.
- C. THE CONTRACTOR IS RESPONSIBLE FOR THE DESIGN, INSTALLATION, AND MAINTENANCE OF ALL TEMPORARY ROOF ACCESS SYSTEMS. ALL SYSTEMS MUST COMPLY WITH OSHA.
- D. COORDINATE STAGING AND MATERIALS STORAGE AREA WITH ANY APPLICABLE PARTIES.
- E. SEE PLAN SET AND/OR SPECIFICATIONS FOR MORE INFORMATION.

RCP GENERAL NOTES

- A. REFER TO ARCHITECTURAL FLOOR PLAN FOR ADDITIONAL DIMENSIONS.
- B. NEW LIGHTING TO BE LOCATED AT UNDERSIDE OF PURLINS

LEGEND

- STANDING SEAM METAL ROOFING
- DOWNSPOUT
- ROOF SLOPE
- AIR TERMINAL
- GROUND ROD
- LIGHTING, SEE ELECTRICAL

KEYNOTES

- 1 (E) LIGHT POLE
- 2 (E) PRESS BOX BELOW
- 3 SNOW GUARD, BOD: COLORGARD SNOW BAR BY ROCKY MOUNTAIN SNOW GUARDS
- 4 ALT. #5: LIGHTNING PROTECTION, BOD: PREFERRED LIGHTNING PROTECTION
- 5 STEEL BEAM, SEE STRUCT
- 6 ALT. #3: PREFINISHED GUTTER AND DOWNSPOUTS
- 7 STEEL PURLIN, SEE STRUCT
- 8 ALT #2: LIGHT FIXTURE PER ELECTRICAL



900 Klamath Avenue
Klamath Falls, OR 97601
541.884.7421

OREGON TECH
3201 CAMPUS DR.
KLAMATH FALLS, OR 97601

**STILWELL
STADIUM
CANOPY**

Oregon TECH
Oregon Institute of Technology

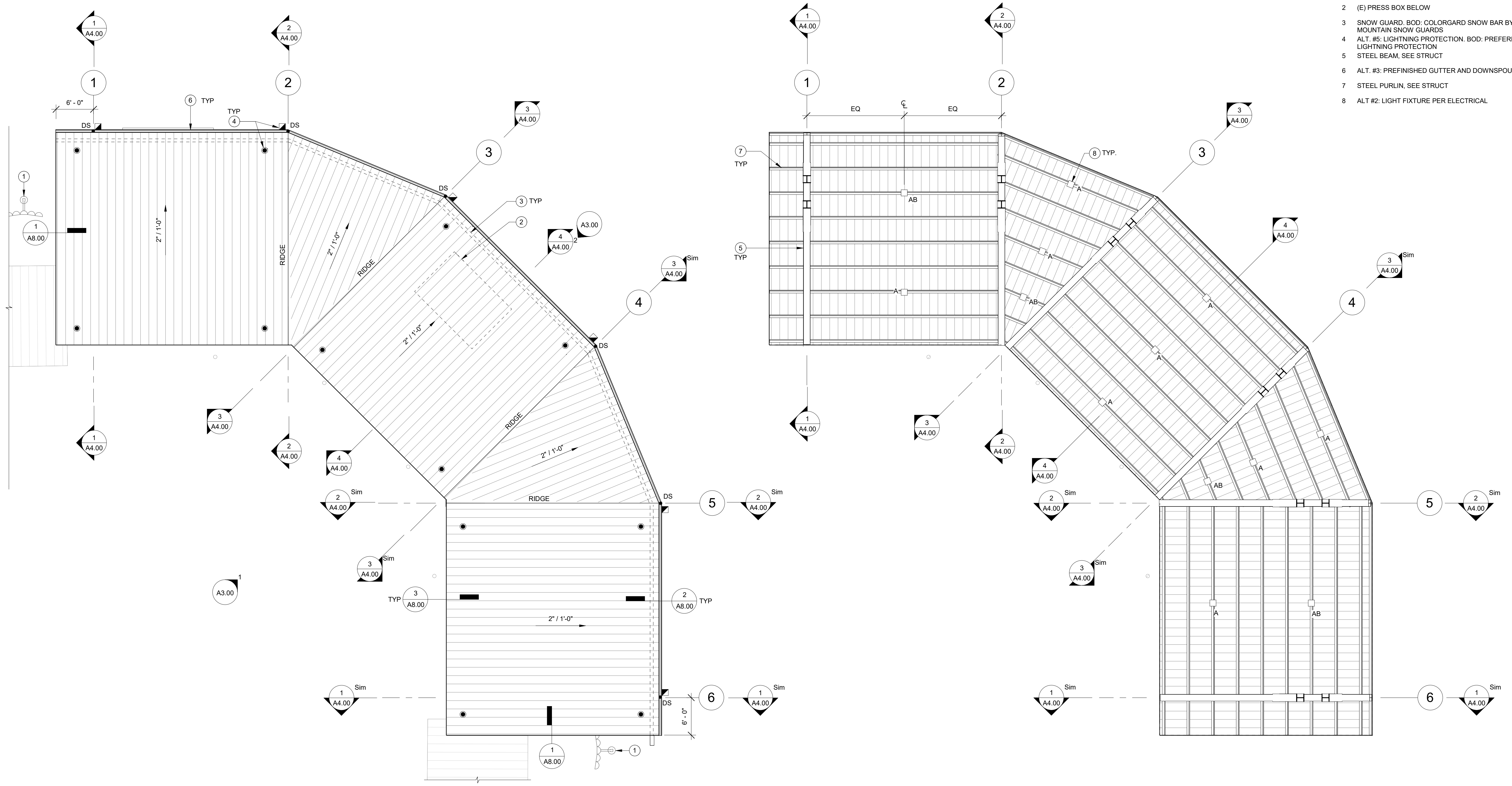

3/9/2026 3:16:26 PM

1
A2.00
ROOF PLAN
1/8" = 1'-0"

2
A2.00
REFLECTED CEILING PLAN
1/8" = 1'-0"



DATE:	Description

PROJECT NO. K-6428-25
DRAWN: JMH
CHECKED: MJC
DATE: 03-11-2026

**ROOF &
REFLECTED
CEILING PLANS**

A2.00

BID AND PERMIT SET | NOT ISSUED FOR CONSTRUCTION

ELEVATION LEGEND

(N) METAL ROOFING

KEYNOTES

- 1 (E) BACKSTOP NETTING POLE
- 2 (E) PRESS BOX
- 3 (E) BLEACHERS
- 4 ALT. #3: PREFINISHED GUTTER AND DOWNSPOUTS
- 5 RETAINING WALL, SEE CIVIL
- 6 STEEL BEAM, SEE STRUCT
- 7 STEEL COLUMN, SEE STRUCT
- 8 STEEL PURLIN, SEE STRUCT



900 Klamath Avenue
Klamath Falls, OR 97601
541.884.7421

OREGON TECH
3201 CAMPUS DR.
KLAMATH FALLS, OR 97601

**STILWELL
STADIUM
CANOPY**

Oregon TECH
Oregon Institute of Technology

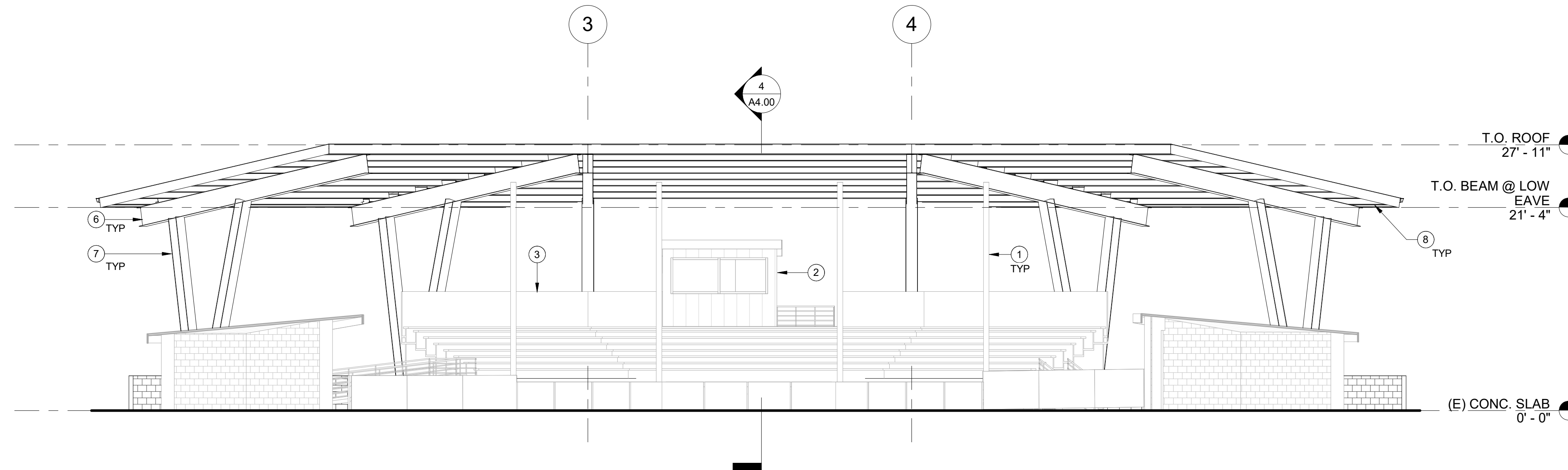

1 FRONT ELEVATION
A3.00 1/8" = 1'-0"

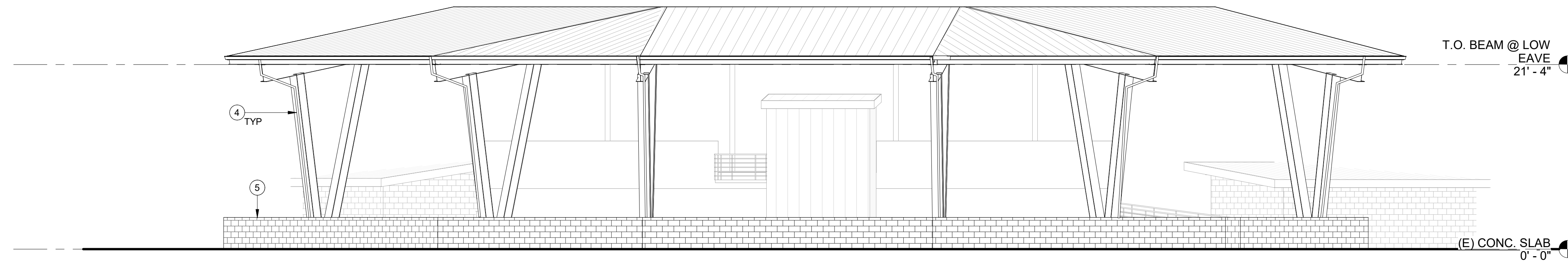

2 REAR ELEVATION
A3.00 1/8" = 1'-0"

3/9/2026 3:16:27 PM

ONE INCH EQUALS FULL SCALE



Δ	DATE:	Description

PROJECT NO. K-6428-25
DRAWN: JMH
CHECKED: MJC
DATE: 03-11-2026

EXTERIOR
ELEVATIONS

A3.00

BID AND PERMIT SET | NOT ISSUED FOR CONSTRUCTION

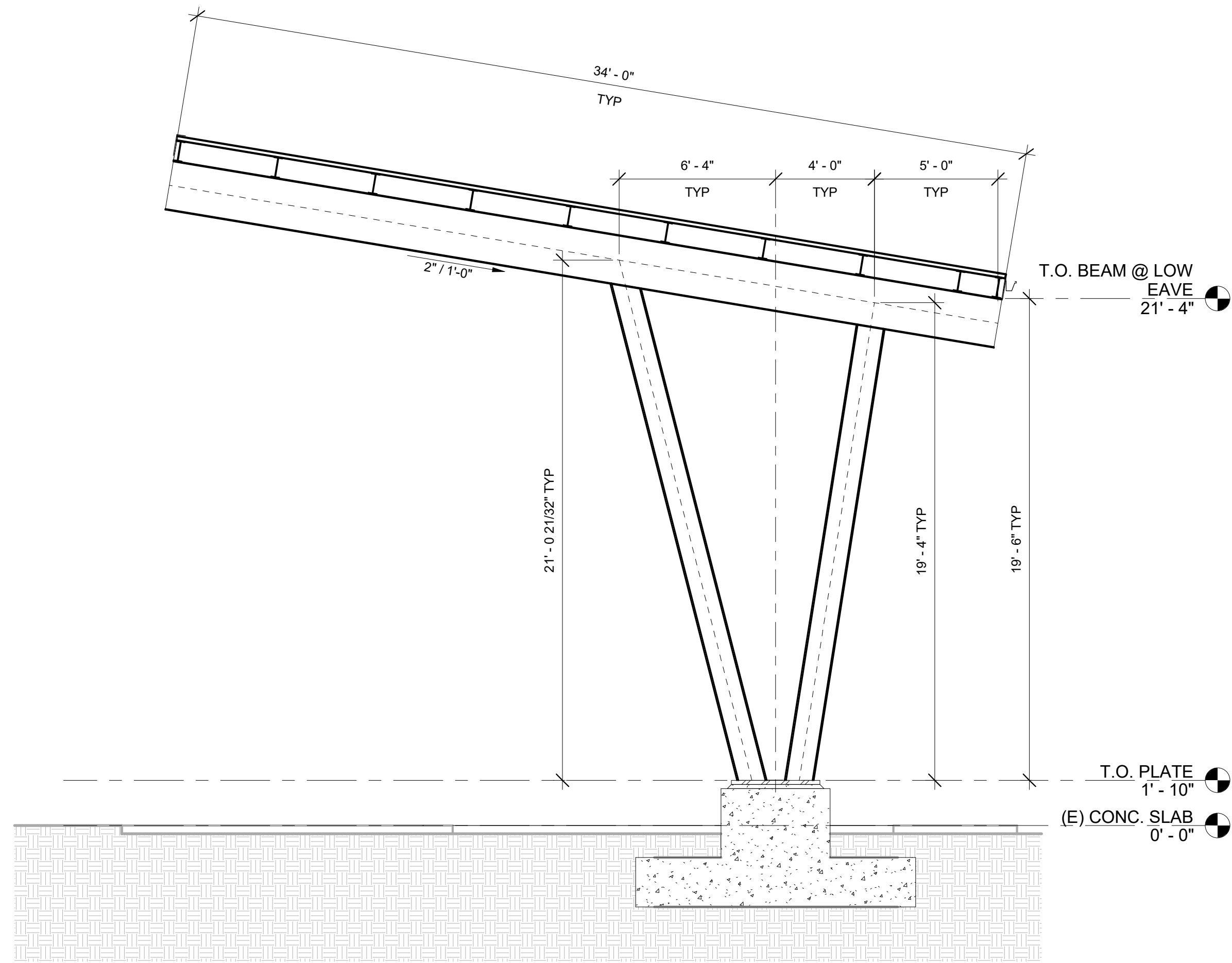

1 FRAME 1 - SECTION
A4.00 1/4" = 1'-0"

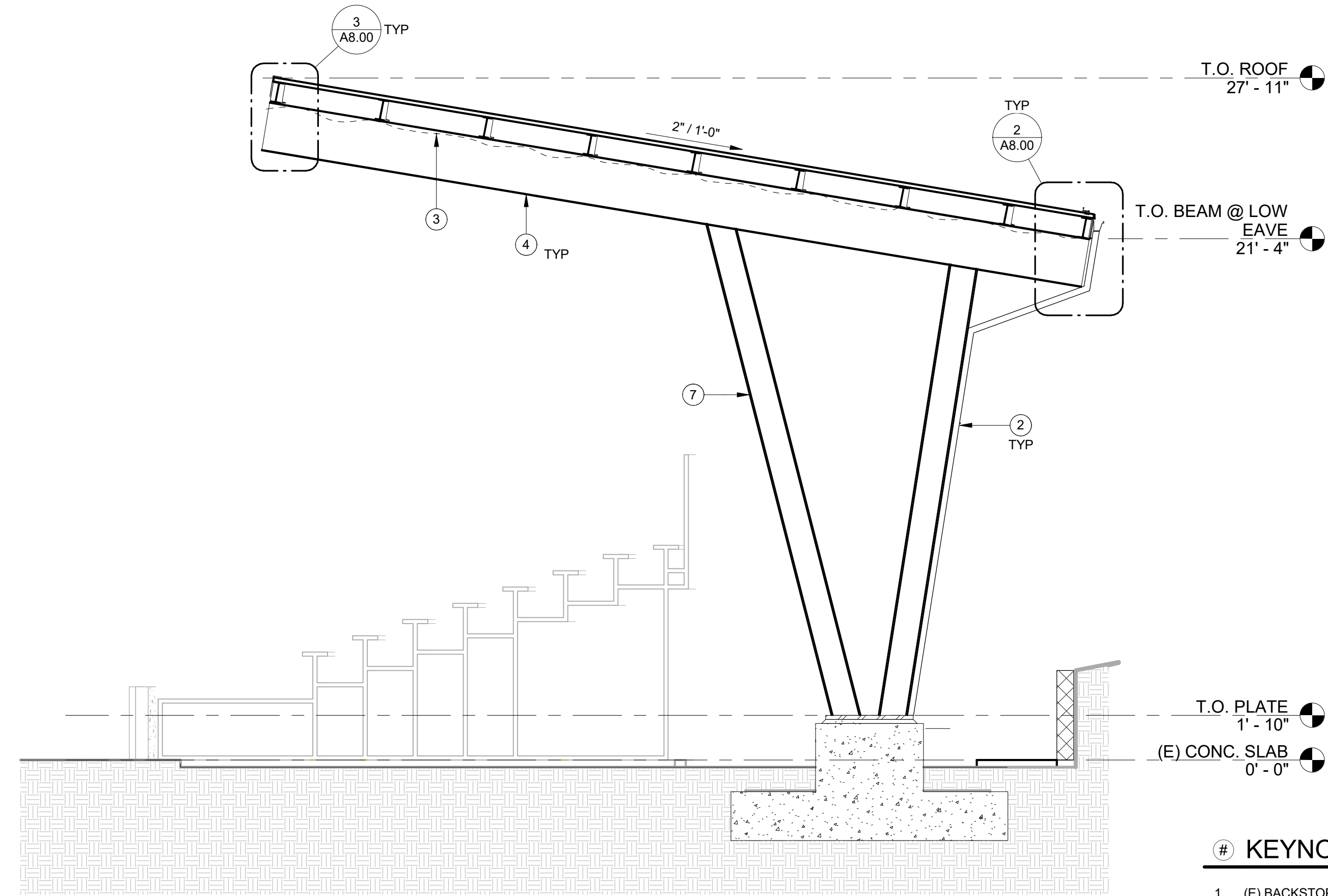

2 FRAME 2 - SECTION
A4.00 1/4" = 1'-0"

KEYNOTES

- 1 (E) BACKSTOP NETTING POLE
- 2 ALT. #3: PREFINISHED GUTTER AND DOWNSPOUTS
- 3 ALT. #6: BIRD NETTING
- 4 STEEL BEAM, SEE STRUCT
- 5 (E) PRESS BOX
- 6 RETAINING WALL, SEE CIVIL
- 7 STEEL COLUMN, SEE STRUCT
- 8 MAINTAIN 6'-8" CLEAR HEIGHT ABOVE SIDEWALK ALONG PATH

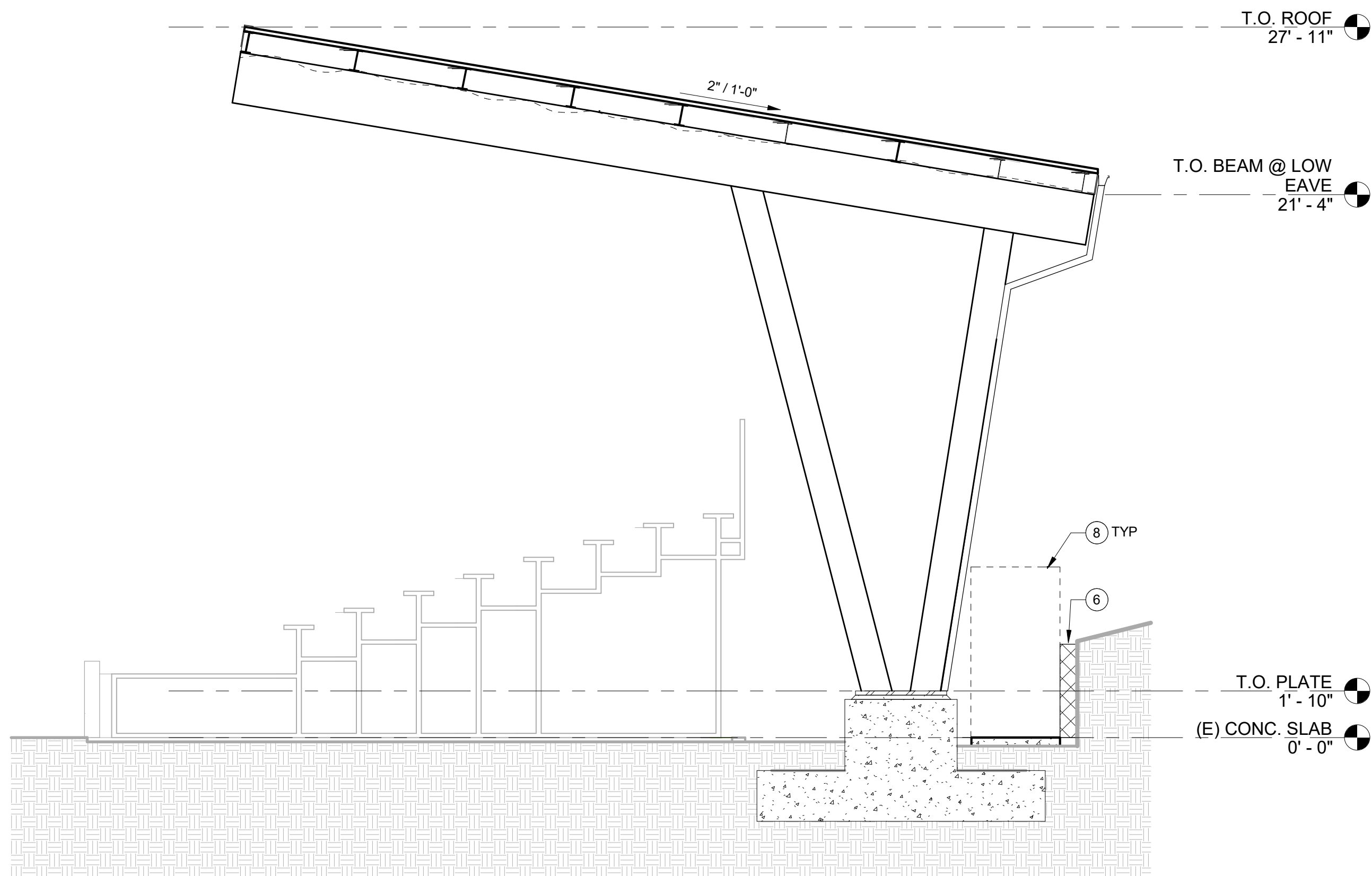

3 FRAME 3 - SECTION
A4.00 1/4" = 1'-0"

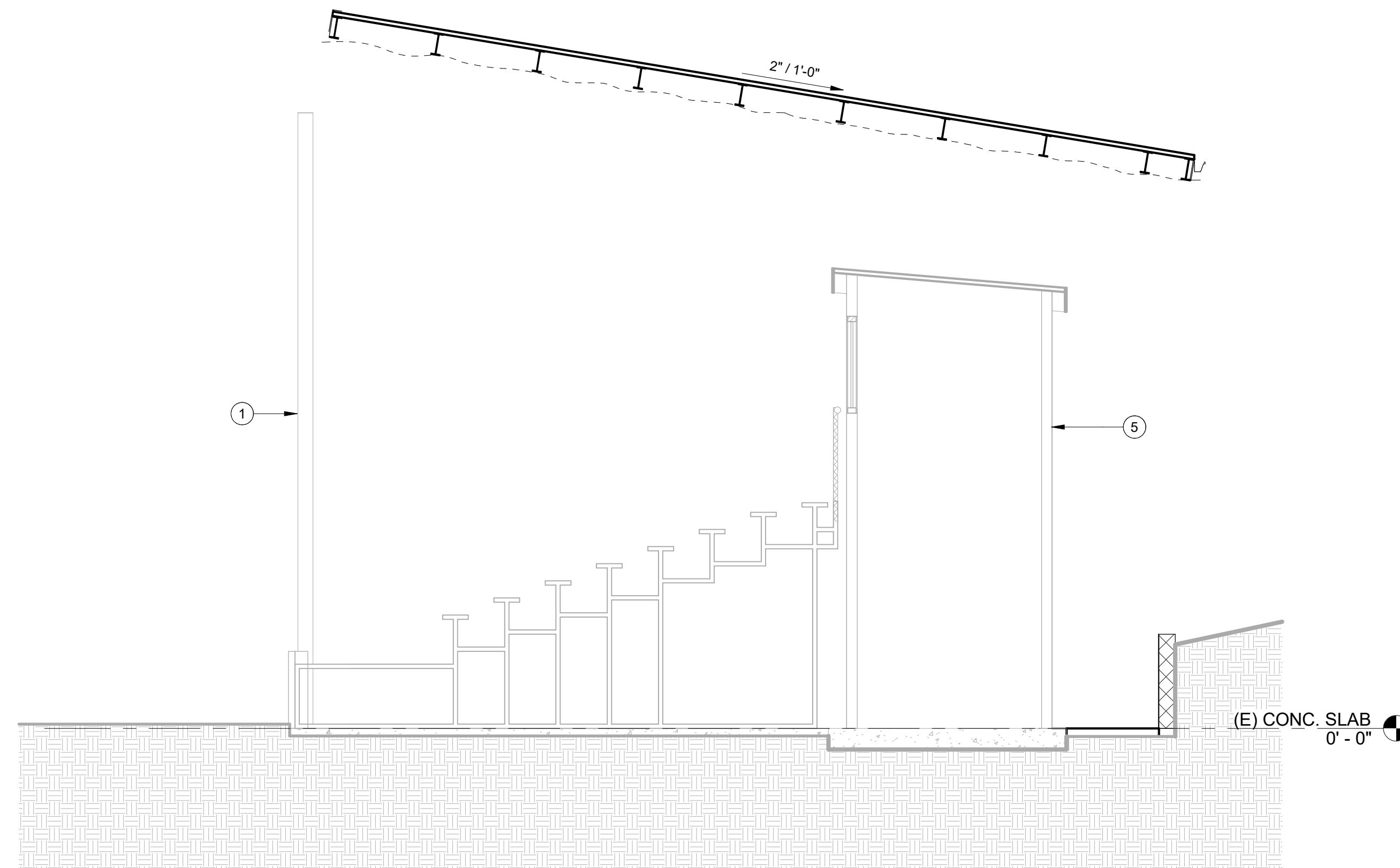

4 CENTERLINE SECTION
A4.00 1/4" = 1'-0"



DATE:	Description

PROJECT NO. K-6428-25
DRAWN: JMH
CHECKED: MJC
DATE: 03-11-2026

SECTIONS

A4.00

3/9/2026 3:16:28 PM
ONE INCH EQUALS FULL SCALE

BID AND PERMIT SET | NOT ISSUED FOR CONSTRUCTION



900 Klamath Avenue
Klamath Falls, OR 97601
541.884.7421

OREGON TECH
3201 CAMPUS DR.
KLAMATH FALLS, OR 97601

**STILWELL
STADIUM
CANOPY**

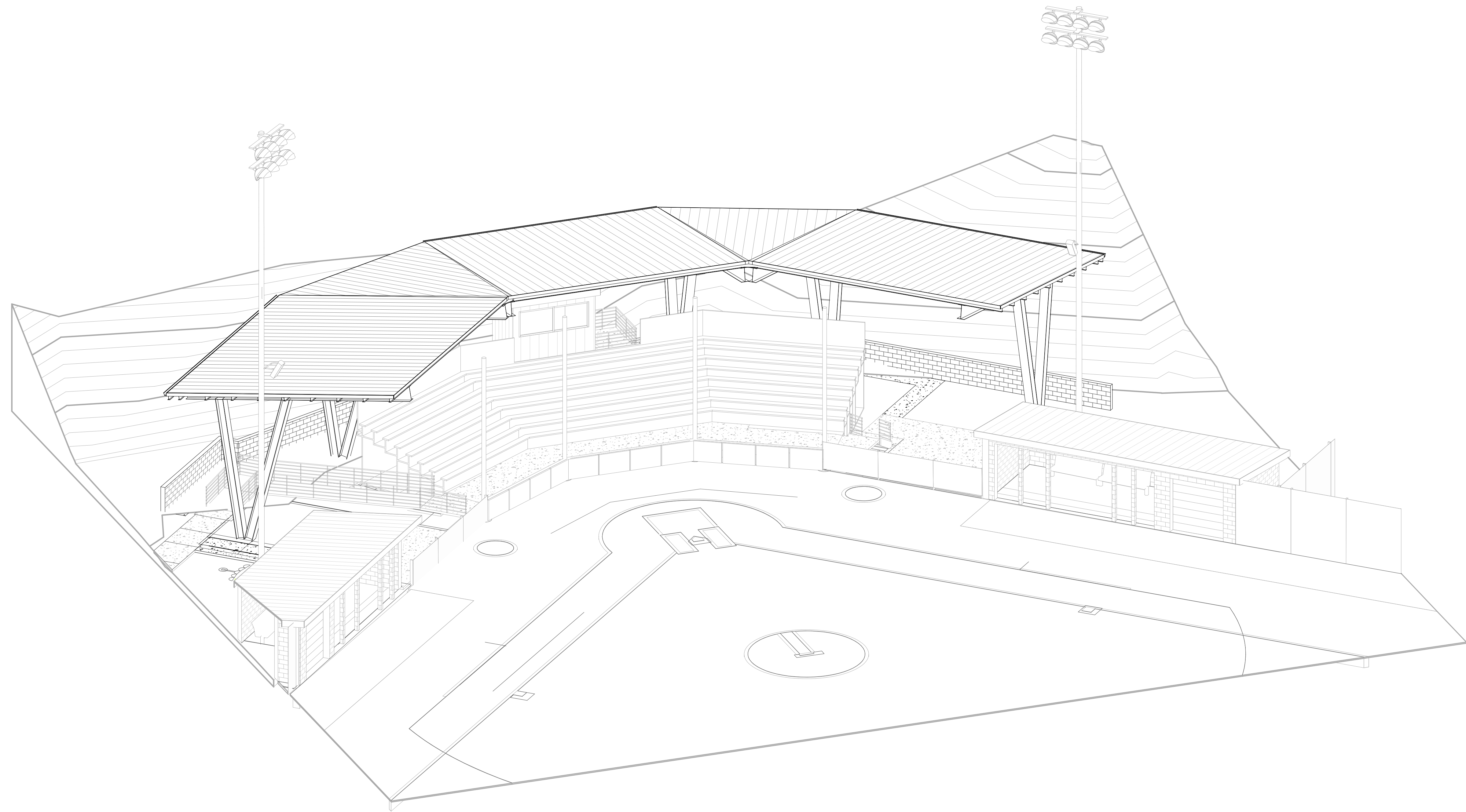

1 BIRDS-EYE VIEW
A5.00

ONE INCH EQUALS FULL SCALE 3/9/2026 3:16:29 PM



△	DATE:	Description

PROJECT NO. K-6428-25
DRAWN: JMH
CHECKED: MJC
DATE: 03-11-2026

BIRDS-EYE VIEW

A5.00

BID AND PERMIT SET | NOT ISSUED FOR CONSTRUCTION

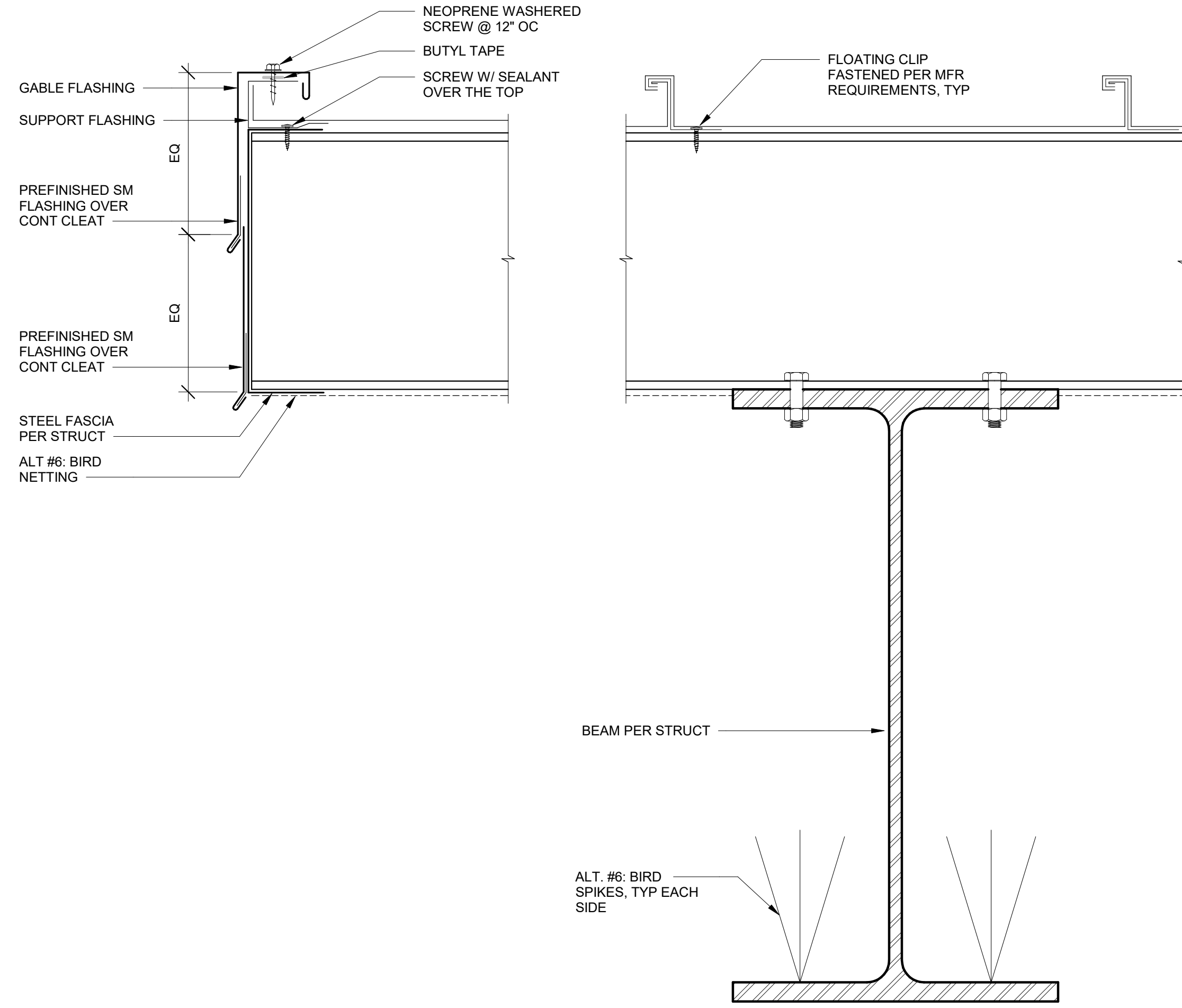

1 CANOPY RAKE
A8.00 3" = 1'-0"

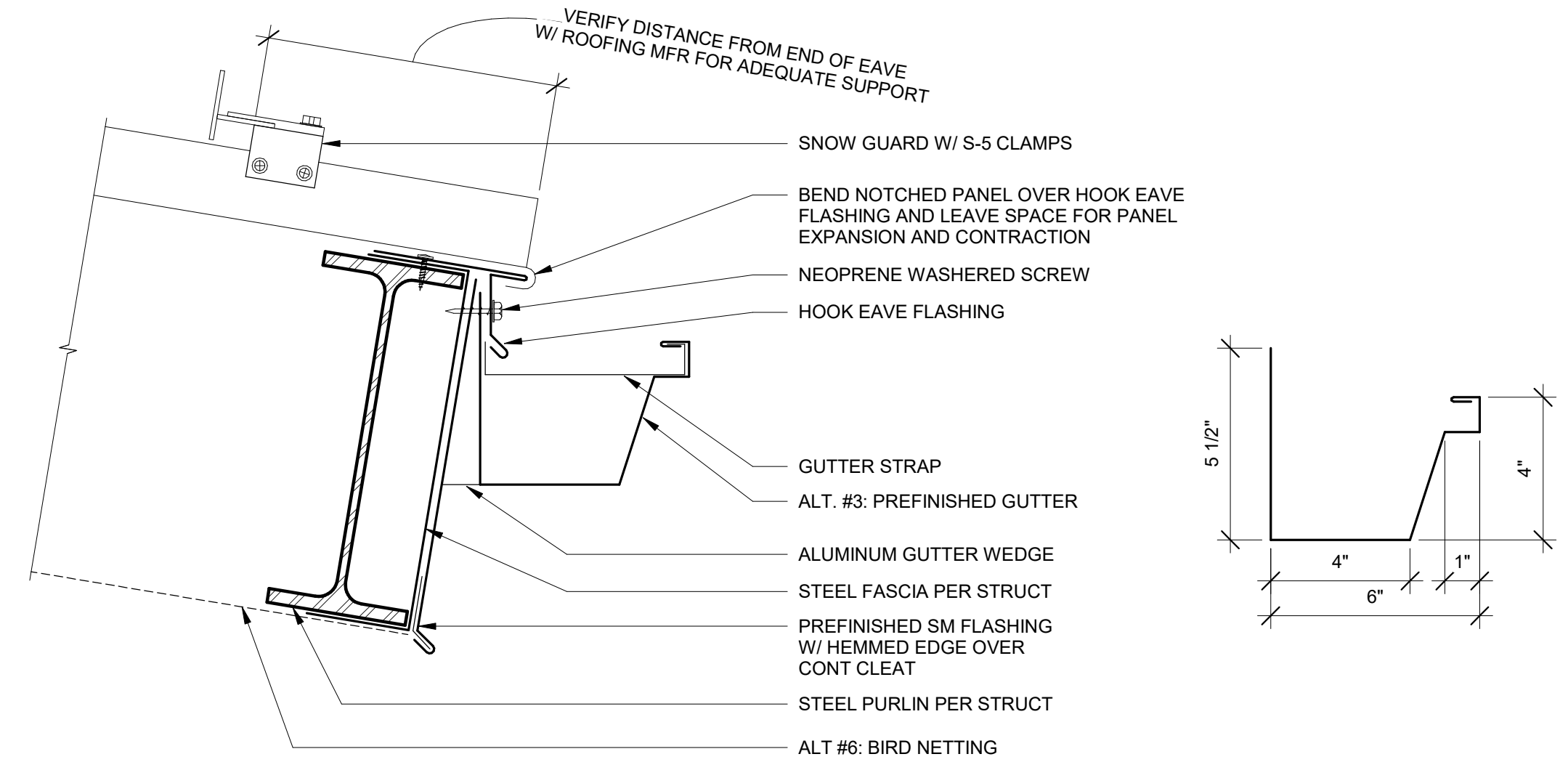

2 CANOPY LOW EAVE
A8.00 3" = 1'-0"

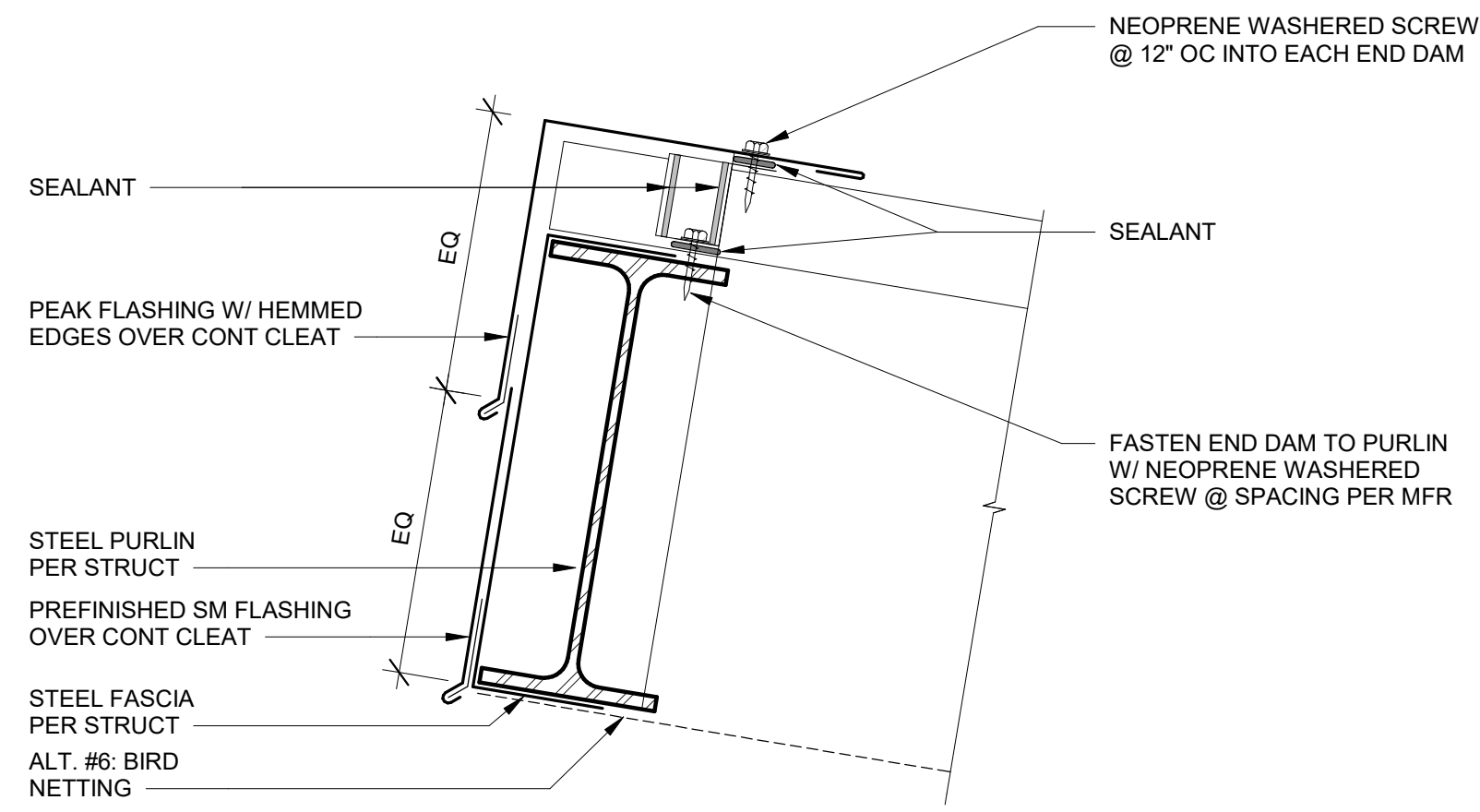

3 CANOPY HIGH EAVE
A8.00 3" = 1'-0"

3/9/2026 3:16:29 PM

ONE INCH EQUALS FULL SCALE

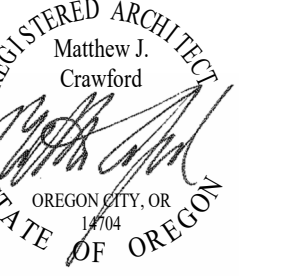

Δ	DATE:	Description

PROJECT NO. K-6428-25
DRAWN: JMH
CHECKED: MJC
DATE: 03-11-2026

EXTERIOR
DETAILS

A8.00

BID AND PERMIT SET | NOT ISSUED FOR CONSTRUCTION

01 33 00 SHOP DRAWINGS, PRODUCT DATA, AND SAMPLES

- 1.1 SUMMARY
 - A. Shop drawing, product data, and sample requirements for all work specified
 - B. Submittals for project closeout
 - C. Related Section: Submittals in Division 1 which provides detailed information on submittal requirements and format.
- 1.2 REQUIREMENTS
 - A. Shop Drawings: Provide shop drawings in a clear and thorough manner. Identify details by reference to drawing and detail schedule, or room numbers shown.
 - B. Products or models. Show performance characteristics and capacities, show dimensions and clearances required. Show wiring or piping diagrams and controls.
 - C. Samples: Samples shall be of sufficient size and quality to clearly illustrate the following: Functional characteristics of the products with integrally related parts and attachment devices and the full range of color, texture, and pattern.
- 1.3 SUBMITTALS REQUIRED:
 - A. SHOP DRAWINGS: Provide shop drawings for the following specified items:
 1. Roofing Assemblies: Include fabrication and installation layouts of metal roof panels; details of edge conditions, joints, panel profiles, corners, anchorages, attachment system, trim, flashings, closures, and accessories; and special details. For accessories, include details of the flashing, trim, and anchorage systems, at a scale of not less than 1-1/2 inches per 12 inches
 2. Sheet Metal Flashing and Trim: plans, elevations, expansion joint locations, keyed details, and attachments to other work. Details of edge conditions, including eaves, ridges, valleys, rakes, crickets, flashings, and counterflashings at scale of not less than 1-1/2 inches per 12 inches.
 3. Snow Guards: Include roof plans showing layouts and attachment details of snow guards.
 4. Lightning Protection: Include layouts of the lightning protection system, with details of the components to be used in the installation. Include raceway locations needed for the installation of conductors. Include roof attachment details, coordinated with roof installation. Details of air terminals, ground rods, ground rings, conductor supports, splices, and terminations, including concealment requirements.
 - B. PRODUCT DATA: Provide product data for the following specified items:
 1. Roof Assemblies: Product data, qualification data for manufacturer and installer, manufacturer certificate certifying roof complies with performance criteria, product test reports, maintenance data, warranties
 2. Sheet Metal Flashing and Trim: For each type of product
 3. Painting: Product data, paint schedule indicating substrate, color, sheen, paint type, and primer.
 4. Snow Guards: Include construction details, material descriptions, dimensions of individual components and profiles, and finishes.
 5. Lightning Protection: For each product.
 - C. SAMPLES: Provide physical samples for the following specified items:
 1. Roof Assembly: Actual sample of finished products for each type of exposed finish for metal roof panels and metal panel accessories.
 2. Sheet Metal Flashing and Trim: For each exposed product and for each color and texture specified.
 3. Painting: Provide 8-inch square draw-downs of each color and sheen used on project.

07 41 13 STANDING SEAM METAL ROOF PANELS

- 1.1 SUMMARY
 - A. Standing-seam metal roof panels
 - B. Underlayment
 - C. Fasteners, adhesives, and other accessories required for complete roof installation.
- 1.2 QUALITY ASSURANCE
 - A. Installer to be approved, authorized, or licensed by roofing system manufacturer to install manufacturer's product and that is eligible to receive manufacturer's warranty.
 - B. Obtain components including fasteners from same manufacturer as roofing or approved by manufacturer.
- 1.3 PERFORMANCE CRITERIA
 - A. Wind Uplift Resistance: Provide metal roof panel assemblies that comply with UL 580 for wind-uplift-resistance class indicated:
 1. Uplift Rating: UL 90
 2. Hail Resistance: HM, UL Class 4 Impact Resistant.
 - B. Structural Performance: Provide metal panel systems capable of withstanding the effects of the following loads, based on testing according to ASTM E 1592
 1. Deflection Limits: For wind loads, no greater than 1/180 for uplift loading and 1/240 for positive loading of the span.
 - C. Water penetration under Static Pressure: No water penetration when tested according to ASTM E 1646.
 - D. Thermal Movements: Allow for thermal movements from ambient and surface temperature changes by preventing buckling, opening of joints, overstressing of components, failure of joint sealants, failure of connections, and other detrimental effects. Base calculation on surface temperatures of materials due to both solar heat gain and nighttime-sky heat loss.
- 1.4 WARRANTY
 - A. Contractor Warranty: The contractor shall warrant the roof application with respect to workmanship and proper application for two years from the date of favorable inspection by the roof membrane manufacturer. Should any leaks covered under the warranty occur during this period, corrective action will be taken by the contractor to repair the roof to the satisfaction of the owner and the roof membrane manufacturer. All corrective work will be done at no cost to the owner or manufacturer.
 - B. Manufacturer Warranty: Manufacturer's standard form in which manufacturer agrees to repair finish or replace metal panels that show evidence of deterioration of factory applied finishes within specified warranty period. Exposed Panel Finish: Deterioration includes, but is not limited to, the following:
 1. Color fading more than 5 Hunter units when tested according to ASTM D2244.
 2. Chalking in excess of a No. 8 rating when tested according to ASTM D4214.
 3. Cracking, checking, peeling or failure of paint to adhere to bare metal.
 - C. Weatherlightness Warranty: Manufacturer's standard form in which manufacturer agrees to repair or replace standing-seam metal roof panel assemblies that fail to remain weatherlight, including leaks, within specified warranty period.
 1. Warranty period: 20 years from date of Substantial Completion.
- 2.1 PRODUCTS
 - A. Manufacturers: See drawings for basis of design system, or comparable product by one of, but not limited to, the following:
 1. Treasure Valley Steel
 2. Taylor Metal Products
 3. Pacific Building Systems
 4. Or Approved Equal.
 - B. Metallic-Coated Steel Sheet: Zinc-coated (galvanized) steel sheet, ASTM A 653 coating designation, or aluminum-zinc alloy-coated steel sheet (Galvalume), ASTM A 792.
 1. Nominal Thickness: 24 Gauge
 2. Exposed Finish: Two-coated Fluoropolymer
 3. Profile Configuration: 2 inch vertical standing seam
 4. Panel Length: Full length, ridge to eave
 - C. Auxiliary Materials
 1. Underlayment: Self-Adhering, High temperature, provide a min. of 40 mil thick polyethylene-film top surface laminated to layer of butyl or SBS-modified asphalt adhesive, with release paper backing.
 2. Factory Prefabricated Flashing: Flashings for pipes, curbs, inside and outside corners of same material and finish of metal panels.
 3. Sealants and Adhesives: per roofing membrane manufacturer.
 4. Panel Fasteners: Self tapping screws designed to withstand design loads.
 5. Roof Panel Accessories: Provide components required for a complete, weatherlight metal roof panel system including trim, copings, fasciae, mullions, sills, corner units, fasteners, flashings, sealants, gaskets, fillers, closure strips, and similar items. Match material and finish of metal roof panels unless otherwise indicated.
- 3.1 EXECUTION
 - A. Examine substrates, areas, and conditions, with Installer present, for compliance with the requirements for installation tolerances, metal panel supports, and other conditions affecting performance of roofing system.
 1. Examine primary and secondary roof framing to verify that rafters, purlins, angles, channels, and other structural panel support members and anchorages have been installed within alignment tolerances required by metal roof panel manufacturer.
 - B. Examine for roughing-in for components and systems penetrating metal panels to verify actual locations of penetrations relative to seam locations or metal panels before installation.
 - C. Proceed with installation only after unsatisfactory conditions have been corrected.
- 3.2 INSTALLATION
 - A. Flashings: Install flashings as indicated on drawings and per manufacturer's recommendations.
 - B. Metal Panels: Install metal panels according to manufacturer's written instructions in orientation, sizes, and locations indicated. Use an approved standing seam metal roof electric seamer to join all panels.

07 62 00 SHEET METAL FLASHING AND TRIM

- 1.1 SUMMARY
 - A. Manufactured reglets and counter flashing
 - B. Formed roof-drainage sheet metal fabrications
 - C. Formed wall sheet metal fabrications
 - D. Formed equipment support flashing
 - E. Self-adhered membrane flashing
 - F. ABS downspouts
 - G. Brake shape aluminum as closure pieces
- 1.2 PERFORMANCE CRITERIA
 - A. Sheet metal flashing and trim assemblies shall withstand wind loads, structural movement, thermally induced movement, and exposure to weather without failure due to defective manufacture, fabrication, installation, or other defects in construction. Completed sheet metal flashing and trim shall not rattle, leak or loosen, and shall remain watertight.
 - B. Sheet Metal Standard for Flashing and Trim: Comply with NCRA's "the NRCA Roofing Manual" and SMACNA's "Architectural Sheet Metal Manual" requirements for dimensions and profiles.
 - C. SPRI Wind Design Standard: Manufacture and install copings complying with SPRI ES-1 and capable of resisting the following design pressure:
 1. Design Pressure: As indicated on Drawings, S0.1
- 2.1 PRODUCTS
 - A. Metallic-Coated Steel Sheet: Provide Zinc-Coated (Galvanized) steel sheet according to ASTM A 653/A 653M, G90 coating designation; prepanning by coil-coating process comply with ASTM A 755/A755M
 1. Surface: Smooth, flat
 2. Exposed Coil-Coated Finish:
 - a. Two-Coat Fluoropolymer: AAMA 621.
 - b. Fluoropolymer finish containing not less than 70 percent PVDF resin by weight in color coat.
 3. Color: Where noted on drawings.
 - B. Fasteners:
 1. Exposed Fasteners: Self-drilling, gasketed, with hex-washer head.
 2. Blind Fasteners: High-strength aluminum or stainless steel rivets suitable for metal.
 3. Galvanized Steel Sheet: Series 300 stainless steel or hot-dip galvanized steel
 - C. Solder: For Galvanized Steel: ASTM B 32, Grade Sn50, 50% tin and 50% lead or Grade Sn 60% tin and 40% lead.
 - D. Sealant: Type: Pressure-sensitive, 100% solids, polyisobutylene compound sealant tape with release-paper backing. Provide permanently elastic, nonsag, nontoxic, nonstaining tape 1/2 inch wide by 1/8 inch thick.
 - E. Elastomeric Sealant: ASTM C 920, x Butyl Sealant: ASTM C 131.1, Type S, Grade NS, Color: gray;
 1. Tremco; Butyl Sealant
 2. DAP; Butyl-Flex
 3. Or equal
 - G. Epoxy Seam Sealer: Two-part, noncorrosive, aluminum seam-cementing compound recommended by aluminum manufacturer for exterior nonmoving joints, including riveted joints.
 - H. Bituminous Coating: Cold-applied asphalt emulsion according to ASTM D 1187
 - I. Self-Adhered Membrane Flashing: Min. 30 mils thick, consisting of slip-resistant polyethylene- or polypropylene-film top surface laminated to a layer of butyl- or SBS-modified asphalt adhesive with release-paper backing; specifically designed to withstand high metal temperatures. Provide primer as recommended by manuf.
 1. Carlisle; CCW WIP 300HT
 2. W. R. Grace Co.; Grace Vycor V40 Self-Adhered Flashing
 3. Henry Co.; Blueskin PE200 HT
 4. Kirsch Building Products; Sharkskin Ultra SA
 5. Metal-Fab Manuf.; MetShield
 6. Owens-Corning; Weatherlock Metal High Temperature Underlayment
 - J. Roof-Drainage Sheet Metal Fabrications
 1. Downspouts: Schedule 40 ABS, 4 inch nom. dia. pipe. Provide elbows with angles of only 45 degrees or less.
 2. Hangers: Custom fabricated, galvanized steel 24 ga., .028 inch thick.
 3. Conductor Heads: Fabricate conductor heads with flanged back and stiffened top edge, complete with outlet tubes, exterior flange trim, and built-in overflows; galvanized steel, 24 ga., .028 inch thick.
 4. Parapet Scuppers: Fabricate with closure flange trim to exterior, 4 inch wide wall flanges to interior, and base extending 4 inches into field of roof; galvanized steel 24 ga., .028 inch thick
 - K. Parapet Sheet Metal Fabrications
 1. Copings: Fabricate in min. 96 inch long max. 12 foot long, sections. Furnish with continuous cleats to support edge of external leg and interior leg. Miter corners, solder or weld watertight. Shop fabricate interior and exterior corners.
 - a. Coping Profile: See drawings
 - b. Joint Style: Butted with expansion space and 6 inch wide, concealed backup plate
 - c. Material: Galvanized steel 20 ga., .040 inch thick
 2. Counterflashing: Shop fabricate interior and exterior corners, galvanized steel 28 ga., .022 inch thick
 3. Flashing receivers: Galvanized steel 28 ga., .022 inch thick
 4. Roof-Penetration Flashing: Galvanized steel 24 ga., .028 inch thick.
- 3.1 EXECUTION
 - A. Install sheet metal flashing and trim true to line, levels, slopes. Provide uniform, neat seams with minimum exposure of solder, welds, and sealant. Do not torch cut sheet metal flashing.
 - B. Space cleats not more than 12 inches apart. Attache cleat with at least two fasteners. Bend tabs over fasteners.
 - C. Where dissimilar metals contact each other, or where metal contacts pressure-treated wood or other corrosive substrates, protect against galvanic action or corrosion by painting contact surfaces with bituminous coating or other permanent separation.
 - D. Expansion Provisions: Provide for thermal expansion of exposed flashing and trim. Space movement joints at max. 10 feet with no joints within 24 inches or corner or intersection. Form expansion joints with intermeshing locked flanges, not less than 1 inch deep, filled with sealant concealed within joints.
 - E. Self-adhering membrane flashing (SAF): Install wrinkle free, shingle fashion to shed water, with end laps of not less than 6 inches staggered 24 inches between courses. Cover SAF within 14 days. Provide a continuous layer of SAF below all parapet copings and as indicated on the drawings.

07 72 53 SNOW GUARDS

- 1.1 SUMMARY
 - A. Section Includes:
 1. Rail-type, seam-mounted snow guards.
- 1.2 FIELD CONDITIONS
 - A. Weather Limitations: Proceed with installation only when existing and forecasted weather conditions permit adhesive-mounted snow guards to be installed, and adhesive cured, according to adhesive manufacturer's written instructions.
- 2.1 PERFORMANCE REQUIREMENTS
 - A. Performance Requirements: Provide snow guards that withstand exposure to weather and resist thermally induced movement without failure, rattling, or fastener disengagement due to defective manufacture, fabrication, installation, or other defects in construction.
 1. Temperature Change: 120 deg F, ambient; 180 deg F, material surfaces.
 - B. Structural Performance: Snow guards to withstand the effects of gravity loads and the following loads and stresses within limits and under conditions indicated.
 1. Snow Loads: As indicated on Drawings
- 2.2 RAIL-TYPE SNOW GUARDS
 - A. Rail-Type, Seam-Mounted Snow Guards:
 1. Basis of Design: Rocky Mountain Snow Guards; S-5 ColorGard Snow Bar System 2.0.
 2. Manufacturers: Subject to compliance with requirements, available manufacturers offering products that may be incorporated into the Work include, but are not limited to, the following:
 - a. Alpine SnowGuards
 - b. Berger; division of OmniMax International, Inc.
 - c. IceBlox Inc.
 - d. LMCurbs
 - e. PMC Industries, Inc
 - f. Rocky Mountain Snow Guards, Inc.
 - g. S-5! Metal Roof Innovations, Ltd.
 - h. TRA Snow and Sun, Inc.
 3. Description: Snow guard rails fabricated from metal pipes, bars, or extrusions, anchored to brackets and equipped with one rail with integral track to accept color-matching inserts of material and finish used for metal roof.
 4. Brackets and Baseplate: ASTM B209 aluminum; mill finished.
 5. Bars: ASTM B221 aluminum; mill finish.
 - a. Profile: Square with integral track to accept color-matching inserts of material and finish used for metal roof.
 6. Seam Clamps: ASTM B221 aluminum extrusion or ASTM B25/B25M aluminum casting with stainless steel set screws incorporating round nonpenetrating point, designed for use with applicable roofing system to which clamp is attached.
- 3.1 EXECUTION
 - A. Install snow guards according to manufacturer's written instructions.
 1. Space rows as recommended by manufacturer.
 - B. Attachment for Standing-Seam Metal Roofing:
 1. Do not use fasteners that will penetrate metal roofing or fastening methods that void metal roofing finish warranty.
 - 2. Rail-Type, Seam-Mounted Snow Guards:
 - a. Install brackets to vertical ribs in straight rows.
 - b. Secure with stainless steel set screws, incorporating round nonpenetrating point, on same side of standing seam.
 - c. Torque set screw in accordance with manufacturer's written instructions.
 - d. Install cross members to brackets.

09 91 00 PAINTING

- 1.1 SUMMARY
 - A. Exterior painting
- 1.2 REGULATORY AGENCY REQUIREMENTS
 - A. Removal of any Lead-based Paint Products (exceeding 20 ft. of exterior surface or 6 sq ft of interior surface) must be performed by Workers who have been pre-certified by EPA.
- 1.3 SITE CONDITIONS
 - A. Perform work only under the following conditions, unless otherwise instructed by Manufacturer:
 1. Maximum relative humidity: 85%
 2. Ambient air temperatures are between 50 degrees and 95 degrees F.
 - B. Maximum moisture content of substrates, when measured with an electronic moisture meter:
 1. Concrete: 12%
 2. Masonry (clay and CMU): 12%
 3. Wood: 15%
 4. Portland cement plaster: 12%
 5. Gypsum board: 12%
- 2.1 EXTERIOR PAINTING SCHEDULE
 - A. Basis of Design is Sherwin Williams, see Finish Schedule for colors.
 - B. Metal
 1. Primer: Pro-Industrial Pro-Cryl Universal Primer B6W1310
 2. (2) Top coats: Pro Industrial Water Based Alkyd Urethane B53 Series
- 3.1 SURFACE PREPARATION
 - A. Steel: Remove all loose mill scale, loose rust, and other foreign material. Clean with solvent per SSPC-SP1, removing all visible oil, grease, soil, drawing and cutting compounds. Change rags and cleaning solution frequently.
 - B. Mildew: Remove any mildew by scrubbing with trisodium phosphate solution. Remove any mildew solution, rinse with clean water, and allow surfaces to complete dry.
- 26 41 13 LIGHTNING PROTECTION FOR STRUCTURES
 - 1.1 SUMMARY
 - A. Section Includes: Lightning protection system for ordinary structures
 - 1.2 PERFORMANCE CRITERIA
 - A. NFPA Lightning Protection Standard: Comply with NFPA 780 requirements for Class 1 buildings.
 - 2.1 PRODUCTS
 - A. Basis of Design: Preferred Lightning Protection.
 - B. Manufacturers: Subject to compliance with requirements, available manufacturers offering products that may be incorporated into the Work include, but are not limited to, the following:
 1. allG Fabrication
 2. East Coast Lightning Equipment Inc.
 3. ERICO; brand of nVent Electrical plc
 4. Harger Lightning & Grounding; business of Harger, Inc.
 5. Heavy Bros. Lightning Protection Co. Inc
 6. Independent Protection Co
 7. National Lightning Protection
 8. Preferred Lightning Protection
 9. Robbins Lightning, Inc
 10. Thompson Lightning Protection, Inc
 11. VFC Lightning Protection
 - 2.2 MATERIALS
 - A. Air Terminals
 1. Aluminum unless otherwise indicated.
 2. 1/2-inch diameter by 16 inches long.
 3. Rounded tip.
 4. Threaded base support.
 - B. Class 1 Main Conductors
 1. Aluminum: 98,800 circular mils in diameter.
 - C. Secondary Conductors
 1. Aluminum: 41,400 circular mils in diameter.
 - D. Ground Rods
 1. Material: Copper-clad steel.
 2. Diameter: 3/4 inch.
 3. Rods shall be not less than 120 inches long.
 - E. Conductor Splices and Connectors: Compression fittings that are installed with hydraulically operated tools, or exothermic welds, approved for use with the class type.
- 3.1 EXECUTION
 - A. Install lightning protection components and systems according to NFPA 780.
 - B. Install conductors with direct paths from air terminals to ground connections. Avoid bends less than 90 degrees and 6 inches in radius and narrow loops.
 - C. Conceal conductors within normal view from exterior locations at grade within 200 feet of building. Comply with requirements for concealed systems in NFPA 780.
 1. Roof penetrations required for down conductors and connections to structural-steel framework shall be made using listed through-roof fitting and connector assemblies with solid rods and appropriate roof flashings. Use materials approved by the roofing manufacturer for the purpose. Conform to the methods and materials required at roof penetrations of the lightning protection components to ensure compatibility with the roofing specifications and warranty.
 2. Install conduit where necessary to comply with conductor concealment requirements.
 - D. Ground Ring Electrode: The conductor shall be not less than the main-size lightning conductor.



900 Klamath Avenue
Klamath Falls, OR 97601
541.884.7421

OREGON TECH
3201 CAMPUS DR.
KLAMATH FALLS, OR 97601

STILWELL
STADIUM
CANOPY



Δ	DATE:	DESCRIPTION

PROJECT NO. K-6428-25
DRAWN: JMH
CHECKED: MJC
DATE: 03-11-2026

ARCHITECTURAL
SPECIFICATIONS

AS.10

FIXTURE TYPE	DESCRIPTION	OUTPUT (LUMENS)	COLOR TEMPERATURE	MOUNTING TYPE / HEIGHT	LOCATION	MANUFACTURER	MODEL	WATTAGE	VOLTAGE	CALCULATED VA (INCL. DRIVER)
A	LED, SQUARE SURFACE MOUNT, DIE CAST ALUMINUM HOUSING (IP65 RATED), 0-10V DIMMING, DLC LISTED, PULL 0-10V DC WIRES FROM DIMMER SWITCH TO LIGHTING LOAD. BRONZE FINISH.	10,000	4000K	SURFACE	STADIUM CANOPY	RAB LIGHTING OR EQUAL	VAN34-90FFR	80	120	100
AB	SAME AS "A" EXCEPT WITH REMOTE EMERGENCY BATTERY BACKUP PROVIDING ILLUMINATION FOR A MINIMUM OF 90 MINUTES. LOCATE REMOTE BACKUP IN THE PRESS BOX NEAR SOURCE PANELBOARD.	10,000	4000K	SURFACE	STADIUM CANOPY	RAB LIGHTING OR EQUAL	VAN34-90FFR WITH IOTA ILBLP-SP18-HE-SD-LC-CW	80	120	100

PRESS BOX LOAD ADDITION					
GIVEN:					
Supply Voltage: 240 / 120V, 1 Phase, 3 Wire					
Press Box Panel Added Load					
Fixture A	0.7	120	1	9 @	84 VA E
Fixture AB	0.7	120	1	4 @	84 VA E
Subtotal Press Box Panel Added Load					1,092 VA
TOTAL ADDED LOAD					1,092 VA
ADDED AMPERAGE AT 240 V, SINGLE-PHASE					4.56 A

ELECTRICAL SYMBOLS

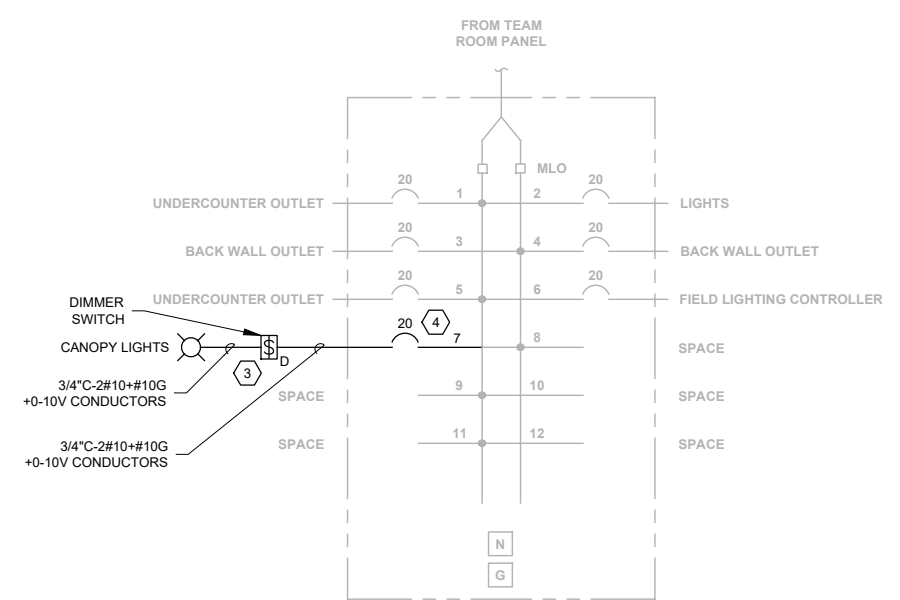
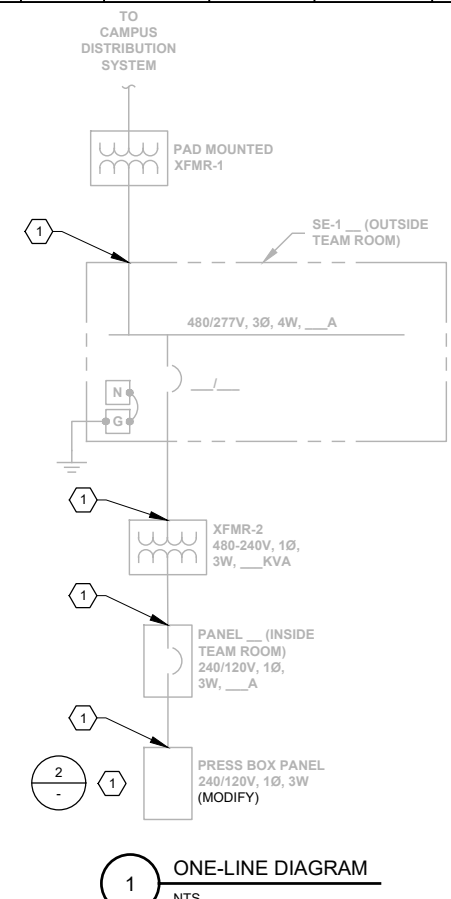
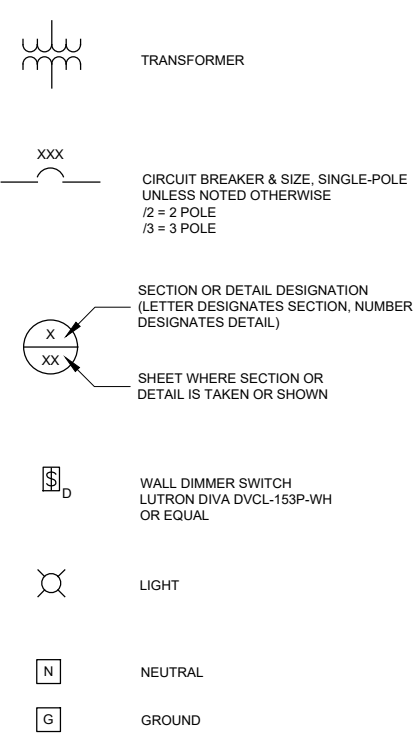

2 PRESS BOX PANEL SCHEDULE
(100A, 240/120V, 1-PHASE, 3 WIRE)

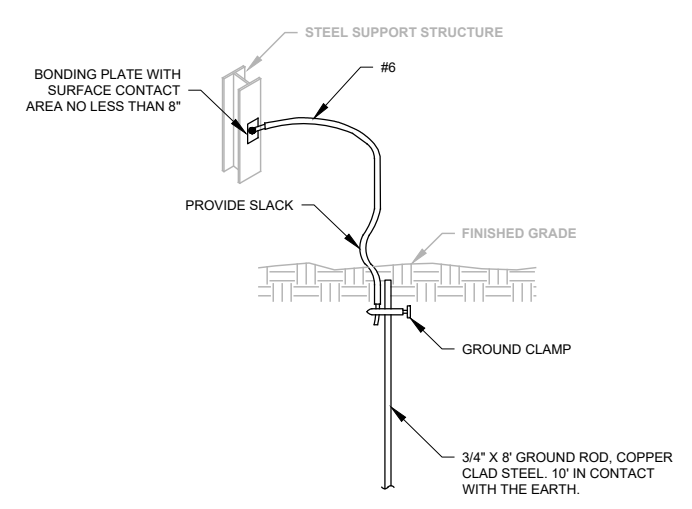

NOTE:
1. CONNECT GROUND ROD TO EACH STEEL SUPPORT STRUCTURE.

3 GROUND ROD (TYP OF 6 CANOPY FOOTINGS)
NTS

DEMAND LOAD ANALYSIS				
EQUIPMENT	EQUIPMENT RATING	MEASURED PEAK LOAD (VA 1)	PROJECT ADDED LOAD (VA 2)	TOTAL CALCULATED LOAD
XFMR-1	___KVA, 480/277V, 3Ø, 4-WIRE			
SE-1 FEEDER	___AWG, ___INSULATION	___A @ ___V, ___Ø (___VA) [CT 1]		(VA 1) + (VA 2) = ___VA ___A @ ___V, ___Ø
SE-1 MAIN BREAKER (IF PRESENT)	___A, ___POLE, ___KAIC			
SE-1 BUS	___A, 480/277V, 3Ø, 4-WIRE, ___KAIC			
XFMR-2 SUPPLY BREAKER WITHIN SE-1	___A, ___POLE, ___KAIC			
XFMR-2 FEEDER	___AWG, ___INSULATION	___A @ ___V, ___Ø (___VA) [CT 2]	4.56A @ 240V, 1Ø (1,092 VA)	(VA 1) + (VA 2) = ___VA ___A @ ___V, ___Ø
XFMR-2	___KVA, 480-240/120V, 1Ø, 3-WIRE			
TEAM ROOM PANEL FEEDER	___AWG, ___INSULATION			
TEAM ROOM PANEL MAIN BREAKER (IF PRESENT)	___A, ___POLE, ___KAIC	___A @ ___V, ___Ø (___VA) [CT 3]		(VA 1) + (VA 2) = ___VA ___A @ ___V, ___Ø
TEAM ROOM PANEL BUS	___A, 240/120V, 1Ø, 3-WIRE, ___KAIC			
PRESS BOX PANEL SUPPLY BREAKER WITHIN TEAM ROOM PANEL	___A, ___POLE, ___KAIC			
PRESS BOX PANEL FEEDER	___AWG, ___INSULATION	___A @ ___V, ___Ø (___VA) [CT 4]		(VA 1) + (VA 2) = ___VA ___A @ ___V, ___Ø
PRESS BOX PANEL BUS	100A, 240/120V, 1Ø, 3-WIRE, ___KAIC			

4 PEAK DEMAND LOAD ANALYSIS
NTS

SCOPE OF WORK

- THIS PROJECT ADDITION OF LIGHTING FOR A NEW CANOPY STRUCTURE OVER THE EXISTING SOFTBALL BLEACHES AT THE OREGON INSTITUTE OF TECHNOLOGY IN KLAMATH FALLS, OREGON. THIS PROJECT INCLUDES, BUT IS NOT LIMITED TO THE FOLLOWING WORK ITEMS:
- ELECTRICAL DEMAND LOAD WAS NOT KNOWN AT TIME OF DESIGN FOR THE ELECTRICAL EQUIPMENT BEING MODIFIED. PERFORM A FIELD INVESTIGATION AS DESCRIBED IN THESE CONTRACT DOCUMENTS TO CONFIRM EXISTING EQUIPMENT CAN SUPPORT PROPOSED ADDED LOADS. PROVIDE AS-BUILT DOCUMENTATION.
- INSTALLATION OF NEW CANOPY MOUNTED AREA LIGHTS
- INSTALLATION OF GROUND RODS AT CANOPY SUPPORT FOOTINGS

SHEET NOTES

- SEE ARCHITECTURAL PLANS FOR LIGHTING FIXTURE A2.00 AND PRESS BOX LOCATIONS
- UNLESS NOTED OTHERWISE, FURNISH COPPER CONDUCTORS WITH THWN INSULATION AND INSTALL IN EMT CONDUIT.
- ITEMS SHOWN THIS IS EXISTING EQUIPMENT TO REMAIN AS IS. ITEMS SHOWN BOLD ON THESE DRAWINGS REPRESENT WORK THAT IS PART OF THIS CONTRACT.

KEY NOTES

- EXISTING LOAD CONDITIONS WERE NOT KNOWN AT THE TIME OF DESIGN FOR PRESS BOX PANEL AND UPSTREAM POWER DISTRIBUTION SYSTEM. AS PART OF THIS PROJECT, PERFORM THE FOLLOWING STEPS TO CONFIRM EXISTING PRESS BOX PANEL AND UPSTREAM POWER DISTRIBUTION SYSTEM ARE SUITABLY RATED TO SUPPORT THE PROPOSED ADDED LIGHTING LOAD:
 - REVIEW AND AS-BUILT THIS PROJECT'S ONE-LINE DIAGRAM AGAINST ACTUAL FIELD CONDITIONS:
 - IDENTIFY BREAKER RATING OF SE-1 SERVING XFMR-2
 - IDENTIFY KVA RATING () OF XFMR-2
 - IDENTIFY XFMR-2 PRIMARY/SECONDARY FEEDER SIZES
 - IDENTIFY THE FOLLOWING FOR TEAM ROOM PANEL:
 - MAIN BREAKER AND BUS RATING OF PANEL
 - BREAKER RATING SERVING PRESS BOX PANEL
 - AS-BUILT PRESS BOX PANEL AND ITS BRANCH CIRCUITS AND VERIFY THAT CIRCUIT 7 IS AVAILABLE FOR A NEW BREAKER. IDENTIFY FEEDER SIZE SERVING PANEL. IDENTIFY EXISTING BREAKER FAULT CURRENT RATINGS.
 - OBTAIN AND PROVIDE TO OWNER A 1-HOUR PEAK DEMAND LOAD ANALYSIS. BY PERFORMING THE FOLLOWING:
 - CONNECT AN RMS CURRENT MONITOR AT THE FOLLOWING LOCATIONS:
 - (CT1) AT SE-1 FEEDER (BETWEEN UTILITY XFMR AND SE-1).
 - (CT2) AT XFMR-2 FEEDER (BETWEEN SE-1 AND XFMR-2).
 - (CT3) AT TEAM ROOM FEEDER (BETWEEN XFMR-2 AND TEAM ROOM PANEL).
 - (CT4) AT PRESS BOX PANEL FEEDER (BETWEEN TEAM ROOM PANEL AND PRESS BOX PANEL).
 - TURN ON ALL CONNECTED LOADS IN PRESS BOX PANEL. TEMPORARILY CONNECT A 1KW HEATER TO A CONVENIENCE RECEPTACLE IN PRESS BOX SO THAT ALL LOADS ARE ON SIMULTANEOUSLY PLUS, THE HEATER.
 - RECORD PEAK LOADS OBSERVED AT CT1, CT2, CT3, AND CT4.
 - VERIFY THAT PEAK LOADS RECORDED AT CT'S WITH LOAD ADDITIONS DOES NOT EXCEED THE FOLLOWING:
 - XFMR-1 RATING.
 - SE-1 FEEDER CONDUCTOR RATINGS.
 - 80% OF SE-1 PANEL MAIN BREAKER RATING (IF PRESENT).
 - SE-1 PANEL BUS RATING.
 - 80% OF CIRCUIT BREAKER RATING FEEDING XFMR-2.
 - XFMR-2 FEEDER CONDUCTOR RATINGS.
 - XFMR-2 RATING.
 - TEAM ROOM PANEL FEEDER CONDUCTOR RATINGS.
 - 80% OF TEAM ROOM PANEL MAIN BREAKER RATING.
 - TEAM ROOM PANEL BUS RATING.
 - 80% OF CIRCUIT BREAKER RATING IN TEAM ROOM PANEL FEEDING PRESS BOX PANEL.
 - PRESS BOX PANEL FEEDER CONDUCTOR RATINGS.
 - PRESS BOX PANEL BUS RATING.
 - DISCONNECT TEMPORARY HEATER AND TURN OFF ALL LOADS.
 - FILL IN THE BLANK CELLS ON THE TABLE SHOWN IN DETAIL 4 THIS SHEET.
- REFERENCE ARCHITECTURAL DRAWING A2.00 FOR FIXTURE A & AB LOCATIONS. FURNISH AND INSTALL FIXTURES, BOXES, RACEWAYS, AND BRANCH CIRCUITING FOR 13 LIGHT FIXTURES.
- LOCATE DIMMER SWITCH INSIDE THE PRESS BOX NEXT TO EXISTING LIGHT SWITCH LOCATION. (SEE ARCHITECTURAL PLANS)
- NEW BREAKER IN PRESS BOX PANEL SHALL HAVE AN AMPACITY RATING AS SHOWN. FIELD INVESTIGATE FAULT CURRENT RATINGS OF EXISTING BREAKERS IN PANEL & PROVIDE A BREAKER WITH FAULT CURRENT MATCHING EXISTING.
- INSTALL GROUND RODS AND BOND TO STEEL STRUCTURE ACCORDING TO NFPA 780 AND AS SHOWN ON DETAIL 3 THIS SHEET.



OREGON TECH
3201 CAMPUS DR.
KLAMATH FALLS, OR 97601

STILWELL STADIUM CANOPY

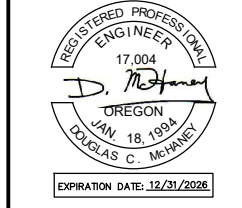

Mar 10, 2026 - 11:48AM PLOTTED BY: mhaerlock P:\2529 OT Stilwell Stadium\10\AucCAD 2026\2529E1.00.dwg ONE INCH EQUALS FULL SCALE

BID AND PERMIT SET | NOT ISSUED FOR CONSTRUCTION

PROJECT NO.	K-6428-25
DRAWN:	MH
CHECKED:	JA
DATE:	03-11-2026

ONE-LINE LOAD SUMMARY, PANELS & GENERAL NOTES

E1.00



PROJECT STRUCTURAL NOTES (KLAMATH FALLS, KLAMATH COUNTY, OR 97601)

GENERAL INFORMATION:

- STRUCTURAL DRAWINGS ARE A PORTION OF THE CONTRACT DOCUMENTS AND ARE INTENDED TO BE USED WITH ARCHITECTURAL, MECHANICAL, AND ELECTRICAL DRAWINGS. THE CONTRACTOR IS RESPONSIBLE FOR COORDINATING THE REQUIREMENTS FROM THESE DRAWINGS INTO THEIR SHOP DRAWINGS AND WORK. THESE GENERAL NOTES SUPPLEMENT THE PROJECT SPECIFICATIONS. REFER TO THE PROJECT SPECIFICATIONS FOR ADDITIONAL REQUIREMENTS. NOTES AND DETAILS ON THE STRUCTURAL DRAWINGS SHALL TAKE PRECEDENCE OVER THE GENERAL NOTES AND TYPICAL DETAILS. WHERE NO DETAILS ARE GIVEN, CONSTRUCTION SHALL BE AS SHOWN FOR SIMILAR WORK.
- THE STRUCTURE IS DESIGNED TO FUNCTION AS A UNIT UPON COMPLETION. THE CONTRACTOR IS RESPONSIBLE FOR FURNISHING ALL TEMPORARY BRACING AND/OR SUPPORT THAT MAY BE REQUIRED AS THE RESULT OF THE CONTRACTOR'S CONSTRUCTION METHODS AND/OR SEQUENCES.
- ALL EXISTING CONDITIONS, DIMENSIONS AND ELEVATIONS SHALL BE FIELD VERIFIED. THE CONTRACTOR SHALL NOTIFY THE ARCHITECT OF ANY SIGNIFICANT DISCREPANCIES FROM CONDITIONS SHOWN ON THE DRAWINGS.
- THE GENERAL CONTRACTOR SHALL BE RESPONSIBLE FOR ALL CONSTRUCTION MEANS AND METHODS. RESPONSIBILITY SHALL INCLUDE BUT NOT LIMITED TO DEMOLITION AND CONSTRUCTION MEANS AND METHODS, TECHNIQUES, SEQUENCING, AND SAFETY REQUIRED TO COMPLETE CONSTRUCTION.
- UNLESS OTHERWISE NOTED, MATERIAL AND DESIGN SPECIFICATIONS CITED HEREIN SHALL BE THOSE CONFORMING WITH THE VERSION OF THE APPLICABLE SPECIFICATIONS OR CODE MOST RECENTLY ADOPTED BY THE PERMITTING AUTHORITY. THESE STRUCTURAL NOTES ARE TO BE USED AS A SUPPLEMENT TO THE SPECIFICATIONS.
- THIS STRUCTURE AND ALL OF ITS PARTS MUST BE ADEQUATELY BRACED AGAINST WIND, LATERAL EARTH AND SEISMIC FORCES UNTIL THE PERMANENT LATERAL-FORCE RESISTING SYSTEMS HAVE BEEN CONSTRUCTED AND ALL ATTACHMENTS AND CONNECTIONS NECESSARY FOR THE STABILITY OF THE STRUCTURE AND ITS PARTS HAVE BEEN MADE.
- ALL FEATURES OF CONSTRUCTION NOT FULLY SHOWN SHALL BE OF THE SAME TYPE AND CHARACTER AS SHOWN FOR SIMILAR CONDITIONS, SUBJECT TO REVIEW BY THE ARCHITECT AND STRUCTURAL ENGINEER OF RECORD.
- ALL PRODUCTS AND MATERIALS USED BY THE CONTRACTOR SHALL BE APPLIED, PLACED, ERECTED OR INSTALLED IN STRICT ACCORDANCE WITH THE MANUFACTURER'S INSTRUCTIONS.
- ALL KEYNOTES INDICATE NEW ITEMS TYPICALLY UNLESS NOTED OTHERWISE.

CODE REQUIREMENT:

- CONFORM TO THE 2022 OREGON STRUCTURAL SPECIALTY CODE, BASED ON THE 2021 INTERNATIONAL BUILDING CODE (IBC). NOTE: THIS APPLIES TO ALL REFERENCES TO OSSC.

DESIGN CRITERIA:

- DESIGN IS BASED ON THE STRENGTH AND DEFLECTION CRITERIA OF THE OSSC. IN ADDITION TO THE DEAD LOADS, THE FOLLOWING LOADING AND ALLOWABLE LOAD IS USED FOR DESIGN:

A.	LIVE LOADS:	
	ROOF	20 PSF
B.	GROUND SNOW LOAD:	28.2 PSF
	EXPOSURE FACTOR	0.9
	SNOW IMPORTANCE FACTOR	1.0
	THERMAL FACTOR	1.2
	FLAT ROOF SNOW LOAD	22 PSF
C.	WIND LOAD:	
	BASIC WIND SPEED (3-SECOND GUST)	98 MPH
	WIND EXPOSURE	C
	WIND IMPORTANCE FACTOR	1.0
	BUILDING CATEGORY	II
	INTERNAL PRESSURE COEFFICIENT	0.00
	TOPOGRAPHIC FACTOR	1.0
D.	EARTHQUAKE DESIGN DATA:	
	RISK CATEGORY	II
	S _s	1.052g
	S ₁	0.397g
	S _{0.5}	0.84g
	S _{0.1}	0.503g
	SITE CLASS	D
	SEISMIC DESIGN CATEGORY	D
	SEISMIC IMPORTANCE FACTOR	1.0
	ANALYSIS PROCEDURE	EQUIVALENT LATERAL FORCE
	BASIC SEISMIC-FORCE RESISTING SYSTEM:	
	STEEL ORDINARY CANTILEVER COLUMNS	
	RESPONSE MODIFICATION FACTOR	R = 1.25
	SEISMIC RESPONSE COEFFICIENT	C _s = 0.672

STRUCTURAL OBSERVATION:

THE STRUCTURAL ENGINEER OF RECORD (SEOR) WILL PERFORM STRUCTURAL OBSERVATION BASED ON THE REQUIREMENTS OF THE OSSC AT THE STAGES OF CONSTRUCTION LISTED BELOW. CONTRACTOR SHALL PROVIDE SUFFICIENT ADVANCED NOTICE AND ACCESS FOR THE SEOR TO PERFORM THESE OBSERVATIONS.

STRUCTURAL OBSERVATION	
ITEM	COMMENTS
PRIOR TO FIRST CONCRETE POUR	AFTER REBAR PLACEMENT
DURING INITIAL STEEL ERECTION	--
PRIOR TO ROOF INSTALLATION	--
AS REQUIRED TO ADDRESS STRUCTURAL ISSUES	--

A FIELD REPORT WILL BE SUBMITTED TO THE BUILDING DEPARTMENT FOLLOWING EACH SITE VISIT.

SPECIAL INSPECTIONS AND TESTING:

- SPECIAL INSPECTION WILL BE PROVIDED BY THE OWNER BASED ON THE REQUIREMENTS OF THE OSSC AS SUMMARIZED IN THE SPECIAL INSPECTION AND TESTING PROGRAM ON SHEETS S0-20-S0-30. CONTRACTOR SHALL PROVIDE SUFFICIENT NOTICE AND ACCESS FOR THE SPECIAL INSPECTOR TO PERFORM THESE INSPECTIONS.

SUBMITTALS:

- SHOP DRAWINGS SHALL BE SUBMITTED TO THE ARCHITECT PRIOR TO FABRICATION AND CONSTRUCTION REGARDING ALL STRUCTURAL ITEMS, INCLUDING THE FOLLOWING:
 - CONCRETE MIX DESIGNS, CONCRETE REINFORCEMENT (INCLUDING MILL TEST REPORTS), STRUCTURAL STEEL (INCLUDING MILL TEST REPORTS)
 - ANY CHANGES TO THE STRUCTURAL DRAWINGS SHALL BE SUBMITTED TO THE ARCHITECT AND ARE SUBJECT TO REVIEW AND ACCEPTANCE OF THE STRUCTURAL ENGINEER OF RECORD.
 - THE CONTRACTOR SHALL COORDINATE SEISMIC RESTRAINTS OF MECHANICAL, PLUMBING, AND ELECTRICAL EQUIPMENT, MACHINERY, AND ASSOCIATED PIPING WITH THE STRUCTURE. ANY CONNECTIONS TO THE STRUCTURE SHALL CONFORM TO OSSC AND SHALL BE SUBMITTED TO THE ARCHITECT PRIOR TO FABRICATION.

DIVISION 03 - CONCRETE

CONCRETE:

- CONCRETE WORK SHALL CONFORM TO CHAPTER 19 OF THE OSSC. CONCRETE STRENGTHS SHALL BE VERIFIED BY STANDARD 28 DAY CYLINDER TESTS PER ASTM C39, AND SHALL BE AS FOLLOWS:

ABSOLUTE WATER-CEMENT RATIO BY WEIGHT			
f _c (PSI)	NON AIR-ENTRAINED	AIR-ENTRAINED	USE
4,000	N/A	0.45	FOOTINGS AND PEDESTALS

MINIMUM CEMENT CONTENT PER CUBIC YARD SHALL BE AS FOLLOWS:

- 1,800 lbs
- FLY ASH CONFORMING TO ASTM C618 (INCLUDING TABLE 2A) TYPE F, MAY BE USED TO REPLACE UP TO 20% OF THE CEMENT CONTENT, PROVIDED THAT THE MIX STRENGTH IS SUBSTANTIATED BY TEST DATA. THE CONTRACTOR SHALL SUBMIT CONCRETE MIX DESIGNS, ALONG WITH TEST DATA COMPLIANT WITH OSSC SECTION 1905, A MINIMUM OF TWO WEEKS PRIOR TO PLACING CONCRETE. NO WATER MAY BE ADDED TO CONCRETE IN THE FIELD UNLESS SPECIFICALLY APPROVED IN WRITING BY THE CONCRETE SUPPLIER IN CONJUNCTION WITH THE CONCRETE MIX DESIGN.
- A WATER-REDUCING ADMIXTURE CONFORMING TO ASTM C494, USED IN STRICT ACCORDANCE WITH THE MANUFACTURER'S RECOMMENDATIONS, SHALL BE INCORPORATED IN CONCRETE DESIGN MIXES. A HIGH-RANGE WATER-REDUCING (HRWR) ADMIXTURE CONFORMING TO ASTM C494, TYPE F OR G, MAY BE USED IN CONCRETE MIXES PROVIDING THAT THE SLUMP DOES NOT EXCEED 8". AN AIR-ENTRAINING AGENT CONFORMING TO ASTM C260 SHALL BE USED IN CONCRETE MIXES FOR EXTERIOR HORIZONTAL SURFACES EXPOSED TO WEATHER. THE AMOUNT OF ENTRAINING AIR SHALL BE 5% +/- 1% BY VOLUME.

CONCRETE CAST IN PLACE:

- CONCRETE SHALL HAVE A MAXIMUM SLUMP OF 4" WITHOUT THE USE OF ADMIXTURES AS NOTED.
- A MINIMUM OF THREE (3) CONCRETE TEST CYLINDERS SHALL BE PROVIDED FOR EACH ONE HUNDRED (100) CU. YARDS, OR EACH DAY OF POUR, FOR EACH CONCRETE STRENGTH. CYLINDERS SHALL BE TESTED AS FOLLOWS:
 - ONE (1) AT SEVEN (7) DAYS, AND
 - TWO (2) AT TWENTY-EIGHT (28) DAYS
- CONCRETE CYLINDER SAMPLING AND TESTING SHALL CONFORM WITH ASTM SPECIFICATIONS. ACCEPTANCE OF CONCRETE SHALL BE GOVERNED BY THE PROVISIONS OF ACI 318-19 "BUILDING CODE REQUIREMENTS FOR REINFORCED CONCRETE". TWO (2) SETS OF MIX DESIGNS, WITH COMPLETE STATISTICAL BACKUP, SHALL BE SUBMITTED FOR REVIEW.
- CONCRETE MATERIALS, FORMWORK, MIXING, PLACING AND CURING SHALL CONFORM WITH THE SPECIFICATIONS CONTAINED IN THE ACI "MANUAL OF CONCRETE PRACTICE".
- AT AREAS OF DEPRESSIONS FOR SLABS AND BEAMS, PROVIDE MINIMUM THICKNESS OF DEPTH AS FOR ADJACENT AREAS, UNLESS NOTED OTHERWISE.
- CONCRETE SHALL NOT BE PLACED ON FROZEN GROUND.
- BOND NEW CONCRETE TO EXISTING CONCRETE WITH "WELD-CRETE", AS MANUFACTURED BY LARSON PRODUCTS CORPORATION, OR APPROVED. AS A MINIMUM, EXISTING CONCRETE SURFACES SHALL BE ROUGHENED BY CHIPPING TO A MINIMUM 1/4" AMPLITUDE TO EXPOSE COARSE AGGREGATE. PREPARATION AND APPLICATION IS TO BE IN STRICT ACCORDANCE WITH THE MANUFACTURER'S RECOMMENDATIONS. ALL EXPOSED CORNERS SHALL HAVE 3/4" CHAMFER, UNLESS NOTES OTHERWISE.

CONCRETE REINFORCING STEEL:

- REINFORCING STEEL SHALL CONFORM TO ASTM A615, GRADE 60, FOR DEFORMED BARS AND ASTM A185 FOR SMOOTH WELDED WIRE FABRIC (WWF), UNLESS OTHERWISE NOTED. REINFORCING STEEL TO BE WELDED SHALL CONFORM TO ASTM A706. REINFORCING STEEL SHALL BE SECURELY TIED IN PLACE WITH #16 ANNEALED IRON WIRE.
- BAR IN SLABS SHALL BE SUPPORTED ON WELL CURED CONCRETE BLOCKS OR APPROVED METAL CHAIRS, AS SPECIFIED BY THE CRSI MANUAL OF STRANDED PRACTICE, MSP-1. REINFORCING STEEL SHALL BE DETAILED IN ACCORDANCE WITH THE "ACI MANUAL OF STANDARD PRACTICE, MSP-1 REINFORCING STEEL SHALL BE DETAILED IN ACCORDANCE WITH THE "ACI MANUAL OF STANDARD PRACTICE FOR DETAILING REINFORCED CONCRETE STRUCTURES", ACI 315. LAP ALL REINFORCING BARS PER THE TYPICAL LAP SPLICE LENGTH SCHEDULE, EXCEPT AS NOTED. MECHANICAL SPLICES NOTED ON THE PLANS SHALL BE DAYTON BAR-GRIP SPLICES OR APPROVED WITH A CURRENT ICC APPROVAL REPORT.

BAR SIZE	TYPICAL LAP SPLICE LENGTH SCHEDULE							
	3,000 psi		4,000 psi		5,000 psi		6,000 psi	
	CASE 1	CASE 2	CASE 1	CASE 2	CASE 1	CASE 2	CASE 1	CASE 2
#3	22	32	19	28	17	25	16	23
#4	29	43	25	37	22	33	20	31
#5	36	54	31	47	28	42	25	38
#6	43	64	37	56	33	50	31	46
#7	63	94	54	81	49	73	44	66

NOTES:

- DIMENSIONS ARE IN INCHES.
 - CASES 1 AND 2 ARE DEFINED AS FOLLOWS: (db = BAR DIAMETER)
 - BEAMS OR COLUMNS:
 - CASE 1: COVER ≥ db AND c-c SPACING ≥ 2db
 - CASE 2: COVER ≥ db OR c-c SPACING < 2db
 - ALL OTHERS:
 - CASE 1: COVER ≥ db AND c-c SPACING ≥ 3db
 - CASE 2: COVER ≥ db OR c-c SPACING < 3db
 - FOR TOP BARS, MULTIPLY LAP LENGTH ABOVE BY 1.3. TOP BARS ARE HORIZONTAL BARS WITH MORE THAN 12" OF CONCRETE CAST BELOW THE BARS.
- REINFORCEMENT SHALL BE SECURED IN FORMS WITH TIES AND ANCHORAGE TO PREVENT DISPLACEMENT. ALL TIE WIRE SHALL BE MIN #16 ANNEALED STEEL.
 - ALL REINFORCING STEEL SHALL BE TIED 100% ALONG ALL PERIMETER EDGES AND 50% FIELD.
 - REINFORCING (MINIMUM UNLESS NOTED OTHERWISE ON PLANS)
 - PLACE TWO (2) NO. 4 CONTINUOUS AT BOTTOM, TOP AND AT DISCONTINUOUS ENDS OF ALL FOUNDATIONS.
 - PLACE BARS AT CORNERS AND INTERSECTIONS FOR WALLS AND FOUNDATIONS EQUAL IN SIZE AND NUMBER TO HORIZONTAL REINFORCING WITH LEGS THAT SATISFY THE REQUIRED LAP SPLICE LENGTH PER SCHEDULE ABOVE.
 - ALL REINFORCING STEEL SHALL BE DETAILED, FABRICATED AND PLACED IN ACCORDANCE WITH ACI DETAILING MANUAL 315.
 - ALL REINFORCING STEEL SHALL BE ACCURATELY AND SECURELY PLACED.
 - REINFORCING SHALL NOT BE BENT OR DISPLACED FOR THE CONVENIENCE OF OTHER TRADES, UNLESS APPROVED BY THE STRUCTURAL ENGINEER.
 - SPLAY REINFORCING STEEL AROUND OPENINGS WITH 1" IN 10" SPLAY, UNLESS NOTED OTHERWISE.
 - MINIMUM COVER FROM CONCRETE SURFACES TO REINFORCING STEEL SHALL BE:
 - 3" TO BOTTOM OF FOOTING
 - 2" TO EARTH FACE OF WALL
 - 3/4" SLAB TO TOP AND BOTTOM SURFACES, CENTER OF SLAB ON GRADE

CONCRETE ACCESSORIES:

- PERMANENTLY EXPOSED EMBEDDED PLATES AND ANGLES SHALL BE HOT-DIPPED, GALVANIZED AFTER FABRICATION, UNLESS OTHERWISE NOTED. NO LOADS OR WELDS SHALL BE PLACED ON EMBEDDED PLATES OR ANGLES FOR A MINIMUM OF 7 DAYS AFTER CASTING.

FOUNDATIONS:

- GENERAL CONTRACTOR SHALL VERIFY ALL DIMENSIONS AND ANCHOR BOLT LAYOUTS PRIOR TO CONSTRUCTION. NOTIFY ENGINEER OF ANY DISCREPANCIES PRIOR TO CONSTRUCTION. FOUNDATION SIZES ARE BASED ON TOTAL LOAD BEARING PRESSURE OF 2,000 psf FOR BEARING ON COMPACTED NATIVE SOILS OR ENGINEERED FILL PER GEOTECHNICAL REPORT BY MARQUESS & ASSOCIATES.
- ALL FOUNDATION ELEMENTS SHALL BE PLACED OVER FIRM, UNDISTURBED NATIVE SOIL OR ON APPROVED STRUCTURAL FILL. THE EXISTING SITE SHALL BE CLEARED AND GRUBBED OF ALL ORGANIC AND/OR EXPANSIVE MATERIAL PRIOR TO STRUCTURAL FILL IMPORT. REFER TO THE PROJECT GEOTECHNICAL REPORT FOR SUBGRADE REQUIREMENTS.
- ALL PERIMETER FOUNDATION ELEMENTS SHALL BE PLACED A MINIMUM OF 24" BELOW LOWEST ADJACENT EXTERIOR GRADE.
- THE GENERAL CONTRACTOR SHALL REVIEW THE PROJECT GEOTECHNICAL REPORT FOR ADDITIONAL RECOMMENDATIONS FOR STRUCTURAL FILL, PLACEMENT OF STRUCTURAL FILL, AND COMPACTION REQUIREMENTS.

NON-SHRINK GROUT:

- GROUT SHALL BE NON-SHRINKABLE. GROUT CONFORMING WITH ASTM C 1107 AND C.R.D. - 621, CORPS OF ENGINEERS "SPECIFICATIONS FOR NON-SHRINK GROUT". GROUT SHALL HAVE A SPECIFIED COMPRESSIVE STRENGTH AT TWENTY-EIGHT (28) DAYS OF 5000 psi. PRE-GROUTING OF BASE PLATES WILL NOT BE PERMITTED.

DIVISION 05 - METALS

STRUCTURAL STEEL AND MISCELLANEOUS IRON:

STRUCTURAL STEEL SHALL BE:

STRUCTURAL STEEL	
ASTM A36	ANGLES AND PLATES, U.N.O.
ASTM A992, GRADE 50	WIDE FLANGE SHAPES

- DESIGN, FABRICATION, AND ERECTION SHALL BE IN ACCORDANCE WITH THE "AISC SPECIFICATION FOR THE DESIGN, FABRICATION, AND ERECTION OF STRUCTURAL STEEL FOR BUILDINGS" WITH "COMMENTARY" AND THE "CODE OF STANDARD PRACTICE", WITH EXCEPTIONS NOTED IN SPECIFICATIONS.
- DRAWINGS ARE DIMENSIONED FOR LAYOUT AND NOT DIMENSIONED PER AISC STANDARDS. IT IS THE RESPONSIBILITY OF THE GENERAL CONTRACTOR TO COORDINATE BETWEEN ALL DRAWINGS AND DEVELOP SHOP DRAWINGS WITH DETAIL AND DIMENSIONING PER AISC.
- ALL FABRICATION, ERECTION, IDENTIFICATION, AND PAINTING SHALL CONFORM TO AISC SPECIFICATIONS.
- ALL STEEL EXPOSED TO WEATHER, SOIL, MOISTURE, OR AS DENOTED ON PLANS SHALL BE HOT DIP GALVANIZED PER ASTM A-123, OR OTHER APPROVED PROTECTIVE COATING.
- ALL WELDING SHALL CONFORM TO AWS (LATEST EDITION) SPECIFICATIONS.
 - ALL WELDERS TO BE QUALIFIED UNDER AWS SPECIFICATIONS WITHIN THE PAST TWO YEARS FOR THE TYPE OF WELDING PERFORMED.
 - ALL WELDS SHALL BE PERFORMED USING PRE-QUALIFIED WELDING PROCEDURES.
 - WELDS FILLER METAL SHALL BE AWS A5.1 OR A5.5 E70XX ELECTRODES OR AWS A5.18 ER70S-X OR A5.2 E7XX-X.
- AFTER FABRICATION, BUT BEFORE INSTALLATION, REMOVE RUST, SCALE, GREASE, AND OIL BY WIRE BRUSHING AND CHEMICAL TREATMENT.
- ALL HIGH-STRENGTH BOLTS, MATERIAL AND INSTALLATION, SHALL CONFORM WITH ASTM STANDARDS.
 - BOLTS SHALL CONFORM WITH ASTM A 325, TYPE N. BOLTS NOT NOTED IN THE DRAWINGS AS TYPE SC SHALL BE TYPE N.
 - FOR BEARING-TYPE CONNECTIONS, TYPE N BOLTS SHALL BE TIGHTENED TO A SNUG TIGHT CONDITION, ONLY.
 - ALL HIGH-STRENGTH BOLTS SHALL BE INSTALLED WITH HARDENED WASHERS, CONFORMING WITH ASTM F 436, AND NUTS, CONFORMING WITH ASTM A 563.
 - ALL BOLTS REQUIRING GALVANIZATION SHALL BE HOT-DIPPED GALVANIZED IN ACCORDANCE WITH ASTM A 153, CLASS C.
 - NO WELDING TO HIGH-STRENGTH BOLTS IS ALLOWED.
- ALL MEMBERS SHALL BE CONNECTED WITH SEMI-FINISHED MACHINE BOLTS, UNLESS NOTED OTHERWISE ON PLANS. MACHINE BOLTS SHALL CONFORM TO ASTM A 307, GRADE A.
- ANCHOR BOLT SHALL CONFORM WITH ASTM F1554 GRADE 55, AND SHALL BE PROVIDED WITH STANDARD WASHERS AND NUTS. GALVANIZE EXTERIOR BOLTS. GALVANIZING SHALL BE IN ACCORDANCE WITH ASTM A 153, CLASS C. NUTS SHALL BE OVER-TAPPED TO CLASS 2A FIT BEFORE GALVANIZING, IN ACCORDANCE WITH ASTM A 563.
- BOLT HEADS OR NUTS BEARING ON SLOPING FLANGES SHALL BE EQUIPPED WITH BEVELED WASHERS. ERECTION AIDS (SUCH AS BOLTS, CLIPS, SHIMS, SEATS OR ANY OTHERS REQUIRED TO FACILITATE CONSTRUCTION) ARE THE RESPONSIBILITY OF THE CONTRACTOR TO DESIGN AND PROVIDE.
- ALL BRACING SHALL HAVE TWO (2) BOLT CONNECTIONS, UNLESS NOTED OTHERWISE. ALL CROSS BRACING SHALL BE BOLTED AT INTERSECTIONS WITH TWO (2) BOLT MINIMUM FOR ST AND ONE (1) BOLT FOR ANGLES. PROVIDE FILLER PLATE BETWEEN CROSS BRACES, AS REQUIRED.
- ALL FIELD WELDS TO GALVANIZED STEEL AND AREAS DAMAGED BY WELDING, FLAME CUTTING OR HANDLING, SHALL BE REPAIRED WITH AN ORGANIC COLD GALVANIZING COMPOUND HAVING A MINIMUM OF NINETY-FOUR PERCENT (94%) ZINC DUST IN THE DRY FILM. APPLY IN MULTIPLE COATS, UNTIL AN 8 MIL THICKNESS HAS BEEN ACHIEVED. SURFACES TO RECEIVE ZINC-RICH PAINT SHALL BE CLEAN, DRY AND FREE OF OIL, GREASE, SALT AND CORROSION PRODUCTS.
- ALL EMBEDDED STEEL SHALL BE FABRICATED FROM MATERIAL CONFORMING WITH THE REQUIREMENTS OF ASTM A 36. HOT-DIP GALVANIZE IN ACCORDANCE WITH ASTM A 123, UNLESS NOTED OTHERWISE.

LIGHT GAUGE STEEL FRAMING:

- STEEL IS TO BE:
 - ASTM A 446 GRADE D (FY = 50 KSI) FOR 12, 14 AND 16 GAUGE.
 - ASTM A 446 GRADE A (FY = 33 KSI) FOR 18 GAUGE AND LIGHTER.
- ALL FABRICATION, ERECTION AND IDENTIFICATION OF LIGHT GAUGE STEEL FRAMING SHALL CONFORM WITH OSSC SECTION 2210 AND AISI "SPECIFICATIONS FOR THE DESIGN OF COLD-FORMED STEEL STRUCTURAL MEMBERS".
- FASTENING OF COMPONENTS SHALL BE WITH SELF-DRILLING SCREWS.
- STEEL STUDS OR JOISTS SHALL BE "S" STUDS OR "J" JOISTS WITH STIFFENED LIPS, UNLESS NOTED OTHERWISE, AS MANUFACTURED BY KNORR STEEL FRAMING SYSTEMS, MEMBERS OF THE METAL STUD MANUFACTURER'S ASSOCIATION, OR APPROVED. SIZE AND GAUGE ARE AS NOTED ON DRAWINGS. PROVIDE ALL ACCESSORIES INCLUDING, BUT NOT NECESSARILY LIMITED TO, TRACKS, CLIPS, WEB STIFFENERS, ANCHORS, FASTENING DEVICES AND OTHER ACCESSORIES REQUIRED FOR A COMPLETE AND PROPER INSTALLATION.

3/9/2026 3:15:48 PM

ONE INCH EQUALS FULL SCALE



OREGON TECH
3201 CAMPUS CR.
KLAMATH FALLS, OR 97601

**STILWELL
STADIUM
CANOPY**

Oregon TECH
Oregon Institute of Technology

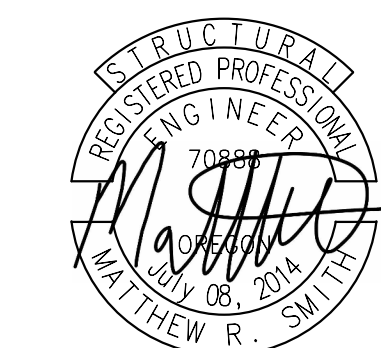

EXPIRES: 06-30-26

Δ	DATE:	Description

PROJECT NO. K-6428-25
DESIGNED BY: DKS
REVIEWED BY: KDM
DATE: 03-11-2026

STRUCTURAL
GENERAL NOTES

S0.10

BID & PERMIT SET | NOT ISSUED FOR CONSTRUCTION

GENERAL - SPECIAL INSPECTIONS					
SYSTEM OR MATERIAL	OSSC CODE REFERENCE	CODE OR STANDARD REFERENCE	FREQUENCY (NOTE 6)		REMARKS
			CONTINUOUS	PERIODIC	
FABRICATORS	1705.11 1704.2.5				SPECIAL INSPECTION IS REQUIRED FOR STRUCTURAL LOAD-BEARING MEMBERS AND ASSEMBLIES FABRICATED ON THE PREMISES OF A FABRICATOR'S SHOP. SPECIAL INSPECTIONS SHALL BE PERFORMED DURING FABRICATION, PERFORMING SPECIAL INSPECTIONS IS NOT REQUIRED, WHERE FABRICATOR HAS BEEN APPROVED AS AN APPROVED FABRICATOR, PER SECTION 1704.2.5.1.
SUBMITTALS TO THE BUILDING OFFICIAL	1704.5			X	CERTIFICATES OF COMPLIANCE, REPORTS OF PRE-CONSTRUCTION TESTS, OR REPORTS OF MATERIAL PROPERTIES SHALL BE SUBMITTED TO THE BUILDING OFFICIAL.
WIND RESISTING COMPONENTS - SPECIAL INSPECTIONS					
ROOF COVERING, ROOF DECK AND ROOF FRAMING CONNECTIONS	1705.12.3			X	

SOILS/GEOTECHNICAL - SPECIAL INSPECTIONS					
SYSTEM OR MATERIAL	OSSC CODE REFERENCE	CODE OR STANDARD REFERENCE	FREQUENCY (NOTE 6)		REMARKS
			CONTINUOUS	PERIODIC	
SOILS					
VERIFY MATERIALS BELOW SHALLOW FOUNDATIONS ARE ADEQUATE TO ACHIEVE THE DESIGN BEARING CAPACITY	1705.6	GEOTECHNICAL REPORT		X	BY THE GEOTECHNICAL ENGINEER OR QUALIFIED SPECIAL INSPECTOR
VERIFY EXCAVATIONS ARE EXTENDED TO PROPER DEPTH AND HAVE REACHED PROPER MATERIAL				X	
PERFORM CLASSIFICATION AND TESTING OF COMPACTED FILL MATERIALS				X	
DURING FILL PLACEMENT, VERIFY USE OF PROPER MATERIALS AND PROCEDURES IN ACCORDANCE WITH THE PROVISIONS OF THE APPROVED GEOTECHNICAL REPORT. VERIFY DENSITIES AND LIFT THICKNESSES DURING PLACEMENT AND COMPACTION OF COMPACTED FILL.				X	
PRIOR TO PLACEMENT OF COMPACTED FILL, INSPECT SUBGRADE AND VERIFY THAT SITE HAS BEEN PREPARED PROPERLY				X	
				X	
MECHANICALLY STABILIZED EARTH (MSE) RETAINING WALLS					
INSTALLATION	1705.1	GEOTECHNICAL AND ICC EVALUATION REPORTS	X		BY THE GEOTECHNICAL ENGINEER SPECIAL INSPECTIONS APPLY TO VERIFYING MODULAR UNIT PRODUCT NAME, TYPE, AND DIMENSIONS, FOUNDATION PREPARATION, MODULAR UNIT PLACEMENT, INCLUDING ALIGNMENT AND INCLINATION, GEOSYNTHETIC REINFORCEMENT PRODUCT NAME, TYPE, AND PLACEMENT, BACKFILL PLACEMENT AND COMPACTION, AND DRAINAGE PROVISIONS

SOILS/GEOTECHNICAL - TESTING					
SYSTEM OR MATERIAL	OSSC CODE REFERENCE	CODE OR STANDARD REFERENCE	FREQUENCY (NOTE 6)		REMARKS
			CONTINUOUS	PERIODIC	
FILL IN-PLACE DENSITY OR PREPARED SUBGRADE DENSITY	1705.6	VARIABLES: GEOTECHNICAL REPORT OR MINIMUM PER OSSC 1803.5.5, 1803.5.6, WHICHEVER IS GREATER		X	BY THE GEOTECHNICAL ENGINEER OR QUALIFIED SPECIAL INSPECTOR
MATERIAL VERIFICATION		VARIABLES: CLASSIFICATION AND TESTING OF CONTROLLED FILL MATERIALS		X	BY THE GEOTECHNICAL ENGINEER OR QUALIFIED SPECIAL INSPECTOR
TEST ELEMENTS	1705.6 1705.7				REFERENCE SPECIFICATIONS FOR PERFORMANCE VERIFICATION AND PROOF LOAD TESTING REQUIREMENTS BY THE GEOTECHNICAL ENGINEER

CONCRETE - SPECIAL INSPECTIONS					
SYSTEM OR MATERIAL	OSSC CODE REFERENCE	CODE OR STANDARD REFERENCE	FREQUENCY (NOTE 6)		REMARKS
			CONTINUOUS	PERIODIC	
GENERAL	1705.3 1901.6	ACI 318: 26.13			SPECIAL INSPECTIONS OF CONCRETE SHALL CONFORM TO THE REQUIREMENTS OF SECTION 1705.3 OF THE IBC AND SECTION 26.13 OF ACI 318.
REINFORCING STEEL PLACEMENT	1901.5	ACI 318: CH. 20, 26.2, 26.3, 26.6.1-26.6.3		X	REINFORCING TO COMPLY WITH ALL CODE PROTECTION, SPACING AND TOLERANCE LIMITS.
INSPECT ANCHORS/BOLTS CAST IN CONCRETE	1705.3	ACI 318: 17.2.5 26.13		X	ALL CAST-IN-PLACE ANCHORS/BOLTS SHALL BE VISUALLY INSPECTED. REFERENCE STEEL INSPECTIONS FOR ADDITIONAL INSTALLATION, MATERIAL AND WELDING INSPECTIONS OF STEEL ITEMS EMBEDDED IN CONCRETE (HEADED STUDS, DBA'S, ETC.)
VERIFYING USE OF REQUIRED MIX DESIGN(S)	1904.1 1904.2 1908	ACI 318: CH. 19, 26.4.3, 26.4.4		X	
CONCRETE SPECIMENS FOR TESTING		ASTM C172 ASTM C31 ACI 318: 26.5, 26.12	X		PRIOR TO CONCRETE PLACEMENT, FABRICATE CONCRETE SPECIMENS FOR TESTING. SEE THE CONCRETE TESTING TABLE FOR ADDITIONAL INFORMATION.
CONCRETE PLACEMENT, NON-SHRINK GROUT	1908	ACI 318: 26.5, 26.13.3.2(a)	X		
CONCRETE CURING	1908.1	ACI 318: 26.5.3 - 26.5.5		X	VERIFY MAINTENANCE OF SPECIFIED CURING TEMPERATURES AND TECHNIQUES
VERIFICATION OF FORMWORK		ACI 318: 28.11.1.2(b), 26.13.3.3		X	SPECIAL INSPECTIONS APPLY TO SHAPE, LOCATION AND DIMENSIONS OF THE CONCRETE MEMBER BEING FORMED
EMBEDDED ITEMS IN CONCRETE				X	ALL NON-STRUCTURAL EMBEDDED ITEMS, SUCH AS CONDUITS, PIPES AND SLEEVES, SHALL BE REVIEWED FOR CONFORMANCE WITH STRUCTURAL DOCUMENTS FOR SIZE, SPACING, LOCATION, EDGE DISTANCE AND TRIM REINFORCING.
REINFORCING STEEL MECHANICAL COUPLERS, TERMINATORS AND FORMSAVERS		ICC EVALUATION REPORTS		X	

CONCRETE - TESTING					
SYSTEM OR MATERIAL	OSSC CODE REFERENCE	CODE OR STANDARD REFERENCE	FREQUENCY (NOTE 6)		REMARKS
			CONTINUOUS	PERIODIC	
CONCRETE STRENGTH	1705.3 ASTM C172 ASTM C 31 ACI 318 26.12, ACI 318 26.5	ASTM C39	EACH 150 CY NOR LESS THAN EACH 5000 SF OF SLAB OR WALL PLACED EACH SHIFT	X	FABRICATE SPECIMENS AT TIME FRESH CONCRETE IS PLACED
CONCRETE SLUMP		ASTM C143			
CONCRETE AIR CONTENT		ASTM C231			
CONCRETE TEMPERATURE		ASTM C1064			

STEEL - SPECIAL INSPECTIONS						
SYSTEM OR MATERIAL	OSSC CODE REFERENCE	CODE OR STANDARD REFERENCE	INSPECTION (NOTES 5 AND 6)		REMARKS	
			CONTINUOUS/PERFORM	PERIODIC/OBSERVE		
CONTRACTOR QUALITY CONTROL REQUIREMENTS		AISC 360 CHAPTER N	X	X	CONTRACTOR TO PROVIDE QUALITY CONTROL FOR ALL ITEMS INDICATED TO BE OBSERVED AND/OR PERFORMED IN TABLE BELOW	
STEEL FABRICATION						
FABRICATION OF STRUCTURAL ELEMENTS	1704.2.5	AISC 360		X	REFER TO INSPECTION OF FABRICATOR REQUIREMENTS	
MATERIAL VERIFICATION OF STRUCTURAL STEEL COMPONENTS	1705.2.1 TABLE 1705.2-3	ASTM A6 ASTM STANDARDS SPECIFIED IN CONSTRUCTION DOCUMENTS AISC 360 A3.1 AISC 360 N2.1		X	CERTIFIED MILL TEST REPORTS	
MATERIAL VERIFICATION OF HIGH STRENGTH BOLTS, NUTS, AND WASHERS	1705.2.1.2 AISC 360 M2.5 TABLE 1705.2-3	AISC 360 A3.3 AISC 360 N3.2 ASTM STANDARDS SPECIFIED IN CONSTRUCTION DOCUMENTS RCSC 2.1		X	MANUFACTURER'S CERTIFIED TEST REPORTS	
MATERIAL VERIFICATION OF ANCHOR BOLTS AND THREADED RODS		AISC 360 A3.4 AISC 360 N3.2 ASTM STANDARDS SPECIFIED IN CONSTRUCTION DOCUMENTS		X	MANUFACTURER'S CERTIFIED TEST REPORTS	
MATERIAL VERIFICATION OF WELD FILLER METALS	1705.2.1.1 TABLE 1705.2-5	AISC 360 A3.5 AISC 360 N3.2 APPLICABLE AWS A5 DOCUMENTS		X	MANUFACTURER'S CERTIFIED TEST REPORTS	
STRUCTURAL STEEL WELDING						
VERIFYING USE OF PROPER WPS'S	1705.2.1 AWS D1.1	AISC 360 N3.2			RETAIN A RECORD OF WELDING PROCEDURE SPECIFICATIONS	
VERIFYING WELDER QUALIFICATIONS	1705.2	AWS D1.1		X	RETAIN A RECORD OF QUALIFICATION CARDS	
COMPLETE AND PARTIAL JOINT PENETRATION GROOVE WELDS	TABLE 1705.2-6a	AWS D1.1 CLAUSE 6		X		
SINGLE PASS FILLET WELDS LESS THAN OR EQUAL TO 5/16"				X		
VERIFICATION OF JOINT & CONNECTION DETAILS INCLUDING MEMBER AND COMPONENT LOCATIONS, BRACING, AND STIFFENERS AT EACH CONNECTION	TABLE 1705.2-7	AWS D1.1		X		
HIGH-STRENGTH BOLTING						
SNUG-TIGHT BOLT INSTALLATION				X	ALL CONNECTIONS VISUALLY INSPECTED AND VERIFIED SNUG	
PRETENSIONED BOLT INSTALLATION USING TURN-OF-THE-NUT METHOD WITH MATCH MARKING, DIRECT TENSION INDICATOR METHOD, OR TWIST-OFF TYPE TENSION CONTROL BOLT METHOD	1705.2.1 TABLE 1705.2-2 AISC 360 M2.5 AISC 360 N5.6	RCSC SPECIFICATION FOR STRUCTURAL JOINTS USING ASTM A325 OR A490 BOLTS SECTION 9 AISC 360 SECTION M2.5		X	ALL CONNECTIONS VISUALLY INSPECTED. CONNECTIONS USING DIRECT TENSION INDICATORS, ALL BOLTS SHALL BE INSPECTED AFTER SNUGGING AND AFTER PRETENSIONING	
PRETENSIONED BOLT INSTALLATION USING TURN-OF-THE-NUT METHOD WITHOUT MATCH MARKING OR CALIBRATED WRENCH METHOD				X	ALL CONNECTIONS VISUALLY INSPECTED	
INSPECTION TASKS PRIOR TO BOLTING						
MANUFACTURER'S CERTIFICATIONS AVAILABLE FOR FASTENER MATERIALS				X		
FASTENERS MARKED IN ACCORDANCE WITH ASTM REQUIREMENTS				X		
PROPER FASTENERS SELECTED FOR THE JOINT DETAIL (GRADE, TYPE, BOLT LENGTH, IF THREADS ARE TO BE EXCLUDED FROM THE SHEAR PLANE)				X		
PROPER BOLTING PROCEDURE SELECTED FOR JOINT DETAIL	1705.2.1.2 TABLE 1705.2-2	AISC 360 TABLE N5.6-1 AISC 360 M2.5		X		
PRE-INSTALLATION VERIFICATION TESTING BY INSTALLATION PERSONNEL OBSERVED AND DOCUMENTED FOR FASTENER ASSEMBLIES AND METHODS USED				X		
PROPER STORAGE PROVIDED FOR BOLTS, NUTS, WASHERS AND OTHER FASTENER COMPONENTS				X		
INSPECTION TASKS DURING BOLTING						
FASTENER ASSEMBLIES, OF SUITABLE CONDITION, PLACED IN ALL HOLES AND WASHERS (IF REQUIRED) ARE POSITIONED AS REQUIRED				X		
JOINT BROUGHT TO THE SNUG-TIGHT CONDITION PRIOR TO THE PRETENSIONING OPERATION	1705.2.1.2 TABLE 1705.2-2	AISC 360 TABLE N5.6-2 AISC M2.5 RCSC SPECIFICATION FOR STRUCTURAL JOINTS USING ASTM A325 OR A490 BOLTS SECTION 9		X		
FASTENER COMPONENT NOT TURNED BY THE WRENCH PREVENTED FROM ROTATING				X		
FASTENERS ARE PRETENSIONED IN ACCORDANCE WITH THE RCSC SPECIFICATION, PROGRESSING SYSTEMATICALLY FROM THE MOST RIGID POINT TOWARD THE FREE EDGES				X		
INSPECTION TASKS AFTER BOLTING						
DOCUMENT ACCEPTANCE OR REJECTION OF BOLTED CONNECTIONS	1705.2.1.2 TABLE 1705.2-2	AISC 360 TABLE N5.6-3	X			



OREGON TECH
3201 CAMPUS CR.
KLAMATH FALLS, OR 97601

STILWELL
STADIUM
CANOPY

Oregon TECH
Oregon Institute of Technology

3/9/2026 3:15:49 PM

ONE INCH EQUALS FULL SCALE

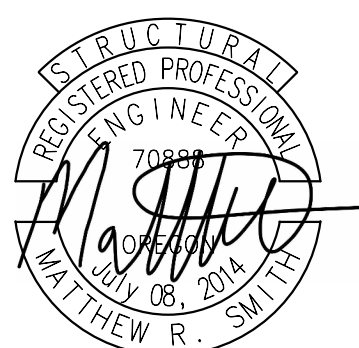

EXPIRES: 06-30-26

DATE	DESCRIPTION

PROJECT NO. K-6428-25
DESIGNED: DKS
REVIEWED: KDM
DATE: 03-11-2026

SPECIAL
INSPECTIONS AND
TESTING

S0.20

BID & PERMIT SET NOT ISSUED FOR CONSTRUCTION

STEEL LATERAL SYSTEM - SPECIAL INSPECTIONS							
SYSTEM OR MATERIAL	OSSC CODE REFERENCE	CODE OR STANDARD REFERENCE	QA/QC TASKS (NOTES 5, 6 AND 10)		REMARKS		
			OBSERVE	PERFORM			
VISUAL INSPECTION TASKS PRIOR TO WELDING							
MATERIAL IDENTIFICATION (TYPE/GRADE)	1705.13.1	AISC 341 TABLE J6.1 AWS D1.8/D1.8M	X				
WELDER IDENTIFICATION SYSTEM			X				
FIT-UP OF GROOVE WELDS (INCLUDING JOINT GEOMETRY)							
JOINT PREPARATION			X				
DIMENSIONS (ALIGNMENT, ROOT OPENING, ROOT FACE, BEVEL)			X				
CLEANLINESS (CONDITION OF STEEL SURFACES)			X		NOTE 7		
TACKING (TACK WELD QUALITY AND LOCATION)			X				
BACKING TYPE AND FIT (IF APPLICABLE)			X				
CONFIGURATION AND FINISH OF ACCESS HOLES			X				
FIT-UP OF FILLET WELDS							
DIMENSIONS (ALIGNMENT, GAPS AT ROOT)			X				
CLEANLINESS (CONDITION OF STEEL SURFACES)			X		NOTE 7		
TACKING (TACK WELD QUALITY AND LOCATION)			X				
VISUAL INSPECTION TASKS DURING WELDING							
WPS FOLLOWED			1705.13.1	AISC 341 TABLE J6.2 AWS D1.8/D1.8M			
SETTINGS ON WELDING EQUIPMENT	X						
TRAVEL SPEED	X						
SELECTED WELDING MATERIALS	X						
SHIELDING GAS TYPE/FLOW RATE	X						
PREHEAT APPLIED	X						
INTERPASS TEMPERATURE MAINTAINED (MIN/MAX)	X						
PROPER POSITION (F, V, H, OH)	X						
INTERMIX OF FILLER METALS AVOIDED UNLESS APPROVED	X						
USE OF QUALIFIED WELDERS	X						
CONTROL AND HANDLING OF WELDING CONSUMABLES							
PACKAGING	X						
EXPOSURE CONTROL	X						
ENVIRONMENTAL CONDITIONS							
WIND SPEED WITHIN LIMITS	X						
PRECIPITATION AND TEMPERATURE	X						
WELDING TECHNIQUES							
INTERPASS AND FINAL CLEANING	X						
EACH PASS WITHIN PROFILE LIMITATIONS	X						
EACH PASS MEETS QUALITY REQUIREMENTS	X						
NO WELDING OVER CRACKED TACKS	X						
VISUAL INSPECTION TASKS AFTER WELDING							
WELDS CLEANED			X				
SIZE, LENGTH, AND LOCATION OF WELDS				X			
WELDS MEET VISUAL ACCEPTANCE CRITERIA							
CRACK PROHIBITION				X(D)			
WELD/BASE-METAL FUSION				X(D)	(D)DOCUMENT - THE INSPECTOR SHALL PREPARE REPORTS INDICATING THAT THE WORK HAS BEEN PERFORMED IN ACCORDANCE WITH THE CONTRACT DOCUMENTS.		
CRATER CROSS SECTION				X(D)	* WHEN WELDING OF DOUBLER PLATES, CONTINUITY PLATES, OR STIFFENERS HAS BEEN PERFORMED IN THE K-AREA, VISUALLY INSPECT THE WEB K-AREA FOR CRACKS WITHIN 3 INCHES OF THE WELD. THE VISUAL INSPECTION SHALL BE PERFORMED NO SOONER THAN 48 HOURS FOLLOWING COMPLETION OF THE WELDING		
WELD PROFILE AND SIZE				X(D)			
UNDERCUT				X(D)			
POROSITY				X(D)			
K-AREA *				X(D)			
PLACEMENT OF REINFORCING OR CONTOURING FILLET WELDS (IF REQUIRED)							
BACKING REMOVED, WELD TABS REMOVED AND FINISHED, AND FILLET WELDS ADDED (IF REQUIRED)				X(D)			
REPAIR ACTIVITIES				X(D)			
VISUAL INSPECTION TASKS PRIOR TO BOLTING							
PROPER FASTENERS SELECTED FOR THE JOINT DETAIL	1705.13.1	AISC 341 TABLE J7.1 RCSC SPECIFICATION FOR STRUCTURAL JOINTS USING HIGH-STRENGT H BOLTS	X				
PROPER BOLTING PROCEDURE SELECTED FOR JOINT DETAIL			X				
CONNECTING ELEMENTS, INCLUDING THE APPROPRIATE FAYING SURFACE CONDITION AND HOLE PREPARATION, IF SPECIFIED, MEET APPLICABLE REQUIREMENTS			X				
PRE-INSTALLATION VERIFICATION TESTING BY INSTALLATION PERSONNEL OBSERVED FOR FASTENER ASSEMBLIES AND METHODS USED			X(D)		(D)DOCUMENT - THE INSPECTOR SHALL PREPARE REPORTS INDICATING THAT THE WORK HAS BEEN PERFORMED IN ACCORDANCE WITH THE CONTRACT DOCUMENTS.		
PROPER STORAGE PROVIDED FOR BOLTS, NUTS, WASHERS AND OTHER FASTENER COMPONENTS			X				

STEEL LATERAL SYSTEM - SPECIAL INSPECTIONS CONT.					
SYSTEM OR MATERIAL	OSSC CODE REFERENCE	CODE OR STANDARD REFERENCE	QA/QC TASKS (NOTES 5, 6 AND 10)		REMARKS
			OBSERVE	PERFORM	
INSPECTION TASKS DURING BOLTING					
FASTENER ASSEMBLIES PLACED IN ALL HOLES AND WASHERS (IF REQUIRED) ARE POSITIONED AS REQUIRED	1705.13.1	AISC 341 TABLE J7.2 RCSC SPECIFICATION FOR STRUCTURAL JOINTS USING HIGH-STRENGT H BOLTS	X		
JOINT BROUGHT TO THE SNUG TIGHT CONDITION PRIOR TO THE PRETENSIONING OPERATION			X		
FASTENER COMPONENT NOT TURNED BY THE WRENCH PREVENTED FROM ROTATING			X		
BOLTS ARE PRETENSIONED PROGRESSING SYSTEMICALLY FROM THE MOST RIGID POINT TOWARD THE FREE EDGES			X		
INSPECTION TASKS AFTER BOLTING					
DOCUMENT ACCEPTED AND REJECTED CONDITION	1705.13.1	AISC 341 TABLE J7.3		X(D)	(D) DOCUMENT - THE INSPECTOR SHALL PREPARE REPORTS INDICATING THAT THE WORK HAS BEEN PERFORMED IN ACCORDANCE WITH THE CONTRACT DOCUMENTS
OTHER INSPECTION TASKS					
CONTOUR AND FINISH	1705.13.1	AISC 341 TABLE J8.1 AISC 358 5.7		X(D)	(D)DOCUMENT - THE INSPECTOR SHALL PREPARE REPORTS INDICATING THAT THE WORK HAS BEEN PERFORMED IN ACCORDANCE WITH THE CONTRACT DOCUMENTS.
DIMENSIONAL TOLERANCES		AISC 341 TABLE J8.1 AISC 341 D1.3 AISC 341 I2.1		X(D)	(D)DOCUMENT - THE INSPECTOR SHALL PREPARE REPORTS INDICATING THAT THE WORK HAS BEEN PERFORMED IN ACCORDANCE WITH THE CONTRACT DOCUMENTS.
PROTECTED ZONE - NO HOLES AND UNAPPROVED ATTACHMENTS MADE BY FABRICATOR OR ERECTOR, AS APPLICABLE					X(D)

STEEL LATERAL SYSTEM - TESTING				
SYSTEM OR MATERIAL	OSSC CODE REFERENCE	CODE OR STANDARD REFERENCE	DESCRIPTION/FREQUENCY	REMARKS
2a) CJP GROOVE WELD NDT	1705.13.1	AISC 341 SECTION J6	UT SHALL BE PERFORMED ON 5/16" THICKNESS AND GREATER. MT SHALL BE PERFORMED ON 25% OF ALL BEAM-TO-COLUMN CJP GROOVE WELDS.	WELD DISCONTINUITIES SHALL BE ACCEPTED OR REJECTED ON THE BASIS OF CRITERIA OF AWS D1.1/D1.1M TABLE 6.2. UT TESTING NOT REQUIRED ON THICKNESS LESS THAN 5/16"
2c) BASE METAL NDT FOR LAMELLAR TEARING AND LAMINATIONS			FOR BASE METAL THICKNESS (t) OF 1/2" AND GREATER AND CONNECTED MATERIAL THICKNESS OF 3/4" AND GREATER, UT FOR DISCONTINUITIES BEHIND AND ADJACENT TO THE FUSION LINE.	ANY BASE METAL DISCONTINUITIES FOUND WITHIN t/4 OF THE STEEL SURFACE SHALL BE ACCEPTED OR REJECTED ON THE BASIS OF THE CRITERIA OF AWS D1.1/D1.1M TABLE 6.2. t IS THE THICKNESS OF THE PART SUBJECTED TO THE THROUGH-THICKNESS STRAIN
2f) WELD TAB REMOVAL SITES			AT THE END OF WELDS WHERE WELD TABS HAVE BEEN REMOVED, MT SHALL BE PERFORMED ON THE SAME BEAM-TO-COLUMN JOINTS RECEIVING UT AS REQUIRED UNDER ITEM 2a	MT OF CONTINUITY PLATE WELD TABS REMOVAL SITES IS NOT REQUIRED.

STEEL - TESTING				
SYSTEM OR MATERIAL	OSSC CODE REFERENCE	CODE OR STANDARD REFERENCE	FREQUENCY (NOTE 6)	REMARKS
STEEL				
ULTRASONIC (UT) TESTING OF WELDS	1705.2.1	AWS D1.1 6.13 & 6.14.3		ALL C.J.P. WELDS 5/16" AND THICKER REQUIRE UT TESTING
MAGNETIC PARTICLE (MT) TESTING OF WELDS	1705.2.1	AWS D1.1 6.14.4 AISC360 N5.5c		REQUIRED AT THERMALLY CUT ACCESS HOLES WHERE FLANGE THICKNESS EXCEEDS 2" FOR ROLLED SHAPES OR WHEN THE WEB THICKNESS EXCEEDS 2" FOR BUILT-UP SHAPES. REQUIRED WHERE SPECIFICALLY NOTED ON DRAWINGS

STATEMENT OF SPECIAL INSPECTION NOTES:

- INSPECTIONS SHALL CONFORM TO SECTION 1705 OF THE 2022 OSSC, CONTRACT DOCUMENTS AND APPROVED SUBMITTALS. REFER TO SPECIAL INSPECTION AND TESTING TABLES FOR PROJECT REQUIREMENTS.
- SPECIAL INSPECTIONS AND ASSOCIATED TESTING SHALL BE PERFORMED BY AN APPROVED ACCREDITED INDEPENDENT AGENCY MEETING THE REQUIREMENTS OF ASTM E329 (MATERIALS). THE INSPECTION AND TESTING AGENCY SHALL FURNISH TO THE STRUCTURAL ENGINEER ARCHITECT A COPY OF THEIR SCOPE OF ACCREDITATION. SPECIAL INSPECTORS SHALL BE APPROVED BY THE BUILDING OFFICIAL. WELDING INSPECTORS SHALL BE QUALIFIED PER SECTION 6.1.4.1(1) OF AWS D1.1.
- THE SPECIAL INSPECTOR SHALL OBSERVE THE INDICATED WORK FOR COMPLIANCE WITH THE APPROVED CONSTRUCTION DOCUMENTS. ALL DISCREPANCIES SHALL BE BROUGHT TO THE ATTENTION OF THE CONTRACTOR FOR CORRECTION AND NOTED IN THE INSPECTION REPORTS.
- THE SPECIAL INSPECTOR AND GEOTECHNICAL ENGINEER SHALL FURNISH INSPECTION REPORTS FOR EACH INSPECTION TO THE BUILDING OFFICIAL, STRUCTURAL ENGINEER, ARCHITECT, CONTRACTOR, AND OWNER. THE SPECIAL INSPECTION AGENCY SHALL SUBMIT A FINAL REPORT STATING THAT THE WORK REQUIRING SPECIAL INSPECTION WAS INSPECTED AND IS IN CONFORMANCE WITH THE APPROVED CONSTRUCTION DOCUMENTS AND THAT ALL DISCREPANCIES NOTED IN THE INSPECTION REPORTS HAVE BEEN CORRECTED.
- QUALITY ASSURANCE (QA) IS REQUIRED FOR STRUCTURAL STEEL ITEMS PER AISC 360 AND 341 UNLESS SPECIFICALLY NOTED OTHERWISE. QUALITY CONTROL (QC) TO BE PROVIDED BY THE FABRICATOR, ERECTOR OR OTHER RESPONSIBLE CONTRACTOR AS APPLICABLE. CONTRACTOR AND SPECIAL INSPECTOR TO DOCUMENT QUALITY CONTROL AS REQUIRED IN AISC 360 SECTION N3 AND AISC 341 SECTION J2.
- INSPECTION TYPES:**
 - CONTINUOUS : THE FULL-TIME OBSERVATION OF WORK REQUIRING SPECIAL INSPECTION BY AN APPROVED SPECIAL INSPECTOR WHO IS PRESENT IN THE AREA WHERE THE WORK IS BEING PERFORMED.
 - PERIODIC : THE PART-TIME OR INTERMITTENT OBSERVATION OF WORK REQUIRING SPECIAL INSPECTION BY AN APPROVED SPECIAL INSPECTOR WHO IS PRESENT IN THE AREA WHERE THE WORK HAS BEEN OR IS BEING PERFORMED AND AT THE COMPLETION OF THE WORK.
 - OBSERVE : OBSERVE THESE FUNCTIONS ON A RANDOM, DAILY BASIS. OPERATIONS NEED NOT BE DELAYED PENDING OBSERVATIONS.
 - PERFORM : INSPECTIONS SHALL BE PERFORMED PRIOR TO THE FINAL ACCEPTANCE OF THE ITEM.
- PERFORM INSPECTION PRIOR TO FINAL ACCEPTANCE OF THE ITEM FOR TEN WELDS TO BE MADE BY A GIVEN WELDER, WITH THE WELDER DEMONSTRATING UNDERSTANDING OF REQUIREMENTS AND POSSESSION OF SKILLS AND TOOLS TO VERIFY THESE ITEMS. THE PERFORM DESIGNATION OF THIS TASK SHALL BE REDUCED TO OBSERVE, AND THE WELDER SHALL PERFORM THIS TASK SHOULD THE INSPECTOR DETERMINE THAT THE WELDER HAS DISCONTINUED PERFORMANCE OF THIS TASK. THE TASK SHALL BE RETURNED TO PERFORM UNTIL SUCH TIME AS THE INSPECTOR HAS RE-ESTABLISHED ADEQUATE ASSURANCE THAT THE WELDER WILL PERFORM THE INSPECTION TASKS LISTED.
- TESTING ABBREVIATIONS:
 - NDT - NON-DESTRUCTIVE TESTING
 - C.J.P. - COMPLETE JOINT PENETRATION
 - MT - MAGNETIC PARTICLE TESTING
 - RBS - REDUCED BEAM SECTION
- DOCUMENT (D): INDICATES CONTRACTOR AND SPECIAL INSPECTOR TO PROVIDE DOCUMENTATION IN ACCORDANCE WITH AISC 341.

CONTRACTOR RESPONSIBILITY:

EACH CONTRACTOR RESPONSIBLE FOR THE CONSTRUCTION OF THE MAIN WIND-OR SEISMIC-FORCE-RESISTING SYSTEM, DESIGNATED SEISMIC SYSTEM OR A WIND-OR SEISMIC-RESISTING COMPONENT LISTED THE TABLES SHALL SUBMIT A WRITTEN STATEMENT OF RESPONSIBILITY TO THE BUILDING OFFICIAL AND THE OWNER PRIOR TO THE COMMENCEMENT OF WORK ON THE SYSTEM OR COMPONENT. THE CONTRACTOR'S STATEMENT OF RESPONSIBILITY SHALL CONTAIN THE FOLLOWING:

ACKNOWLEDGEMENT OF AWARENESS OF THE SPECIAL REQUIREMENTS CONTAINED IN THE STATEMENT OF SPECIAL INSPECTIONS.

- ACKNOWLEDGEMENT THAT CONTROL WILL BE EXERCISED TO OBTAIN CONFORMANCE WITH THE CONSTRUCTION DOCUMENTS APPROVED BY THE BUILDING OFFICIAL.
- PROCEDURES FOR EXERCISING CONTROL WITHIN THE CONTRACTOR'S ORGANIZATION, THE METHOD AND FREQUENCY OF REPORTING AND DISTRIBUTION OF THE REPORTS.
- IDENTIFICATION AND QUALIFICATIONS OF THE PERSON(S) EXERCISING SUCH CONTROL AND THEIR POSITION(S) IN THE ORGANIZATION.

3/9/2026 3:15:49 PM

ONE INCH EQUALS FULL SCALE



900 Klamath Avenue
Klamath Falls, OR 97601
541.884.7421

OREGON TECH
3201 CAMPUS CR.
KLAMATH FALLS, OR 97601

STILWELL
STADIUM
CANOPY

Oregon TECH
Oregon Institute of Technology

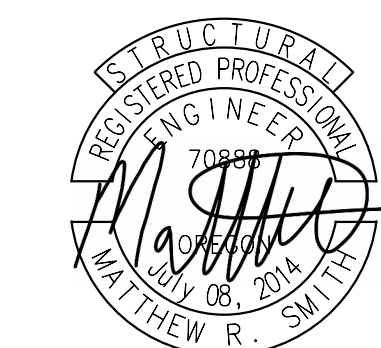

EXPIRES: 06-30-26

DATE	Description

PROJECT NO. K-6428-25
DESIGNED: DKS
REVIEWED: KDM
DATE: 03-11-2026

SPECIAL
INSPECTIONS AND
TESTING

S0.30

BID & PERMIT SET NOT ISSUED FOR CONSTRUCTION



OREGON TECH
3201 CAMPUS CR.
KLAMATH FALLS, OR 97601

**STILWELL
STADIUM
CANOPY**

Oregon TECH
Oregon Institute of Technology

FOUNDATION PLAN NOTES

- A. DIMENSIONS SHOWN ARE FOR REFERENCE ONLY, CONFIRM WITH ARCHITECTURAL PLAN & DETAILS.
- B. BOTTOM OF FOOTINGS TO BE PLACED BELOW FROST DEPTH OR AS NOTED IN THE GEOTECHNICAL REPORT, WHICHEVER IS GREATER.
- C. COORDINATE PENETRATIONS OF SITE UTILITIES, MECHANICAL DUCTS, PIPING, AND ELECTRICAL CONDUIT/PANELS TO MINIMIZE IMPACT TO STRUCTURAL FRAMING.
- D. ALL FOOTINGS ARE TO BE CENTERED UNDER COLUMNS, U.N.O.
- E. ALL FOOTINGS TO BEAR OVER GRADE OVER FIRM, UNDISTURBED, NON-ORGANIC, NON-EXPANSIVE NATIVE MATERIAL AND STRUCTURAL FILL AS REQUIRED PER DETAIL 1/S3.10.
- F. SEE SHEET S0.10 FOR ADDITIONAL NOTES AND SCHEDULES.
- G. ALL KEYNOTES INDICATE NEW ITEMS TYPICALLY, U.N.O.
- H. (F-XX) INDICATES FOOTING TYPE PER FOUNDATION SCHEDULE.

FOUNDATION PLAN KEYNOTES

- 1. 2'-10"x4'-5" CONCRETE PEDESTAL w/ (44) #6 VERT. AND #4 HOOPS @ 6" o.c. PROVIDE (10) ADDITIONAL #4 CROSSIES, SPACING TO MATCH HOOP SPACING.
- 2. FOOTING TO BE UNDERMINED UNDER (E) THICKENED SLAB.

ROOF FRAMING PLAN NOTES

- A. COORDINATE ALL DIMENSIONS & FEATURES NOT SHOWN WITH ARCHITECT.
- B. SEE SHEET S0.10 FOR ADDITIONAL NOTES AND SCHEDULES.
- C. ALL KEYNOTES INDICATE NEW ITEMS TYPICALLY, U.N.O.
- D. BEAMS ARE EQUALLY SPACED IN BAYS, U.N.O.
- E. BEAMS ARE CENTERED ON COLUMNS, WALLS, AND/OR GRID LINES, U.N.O.

ROOF FRAMING PLAN KEYNOTES

- 1. ROOF PANELS PER ARCH.
- 2. PROVIDE L2x2x1/4 ANGLE BRIDGING EACH BAY.
- 3. 1/2"Ø A36 X-ROD BRACES WITH TURNBUCKLES AS REQUIRED. TIGHTEN TURNBUCKLES UNTIL RODS ARE PULLED TAUGHT. PROVIDE ROD SUPPORT @ 12'-0" MAX. SEE DETAIL 1/S3.20 FOR ADDITIONAL INFORMATION.
- 4. PROVIDE 16 GA. BENT CFS FASCIA w/ MIN. 2" LEGS FOR FULL LENGTH OF EAVE.

FOUNDATION SCHEDULE				
MARK	WIDTH	LENGTH	DEPTH	REINFORCEMENT
F-1	12' - 0"	12' - 0"	3' - 0"	(22) #6 E.W. TOP AND BOTTOM

1. UNLESS NOTED OTHERWISE, REINFORCEMENT TO BE SPACED EVENLY IN FOOTING WITH CORRECT SIDE AND BOTTOM CLEARANCES.

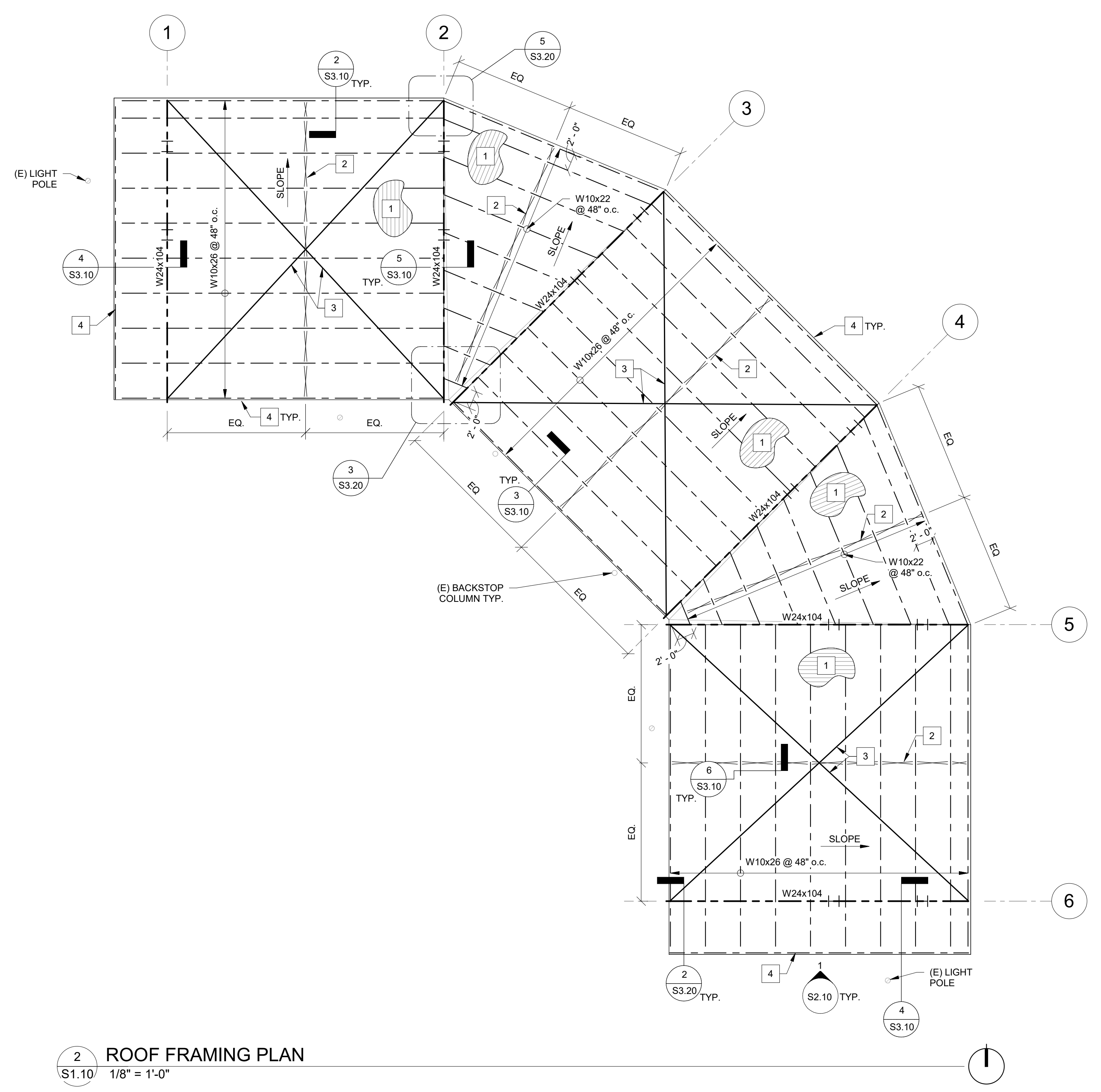
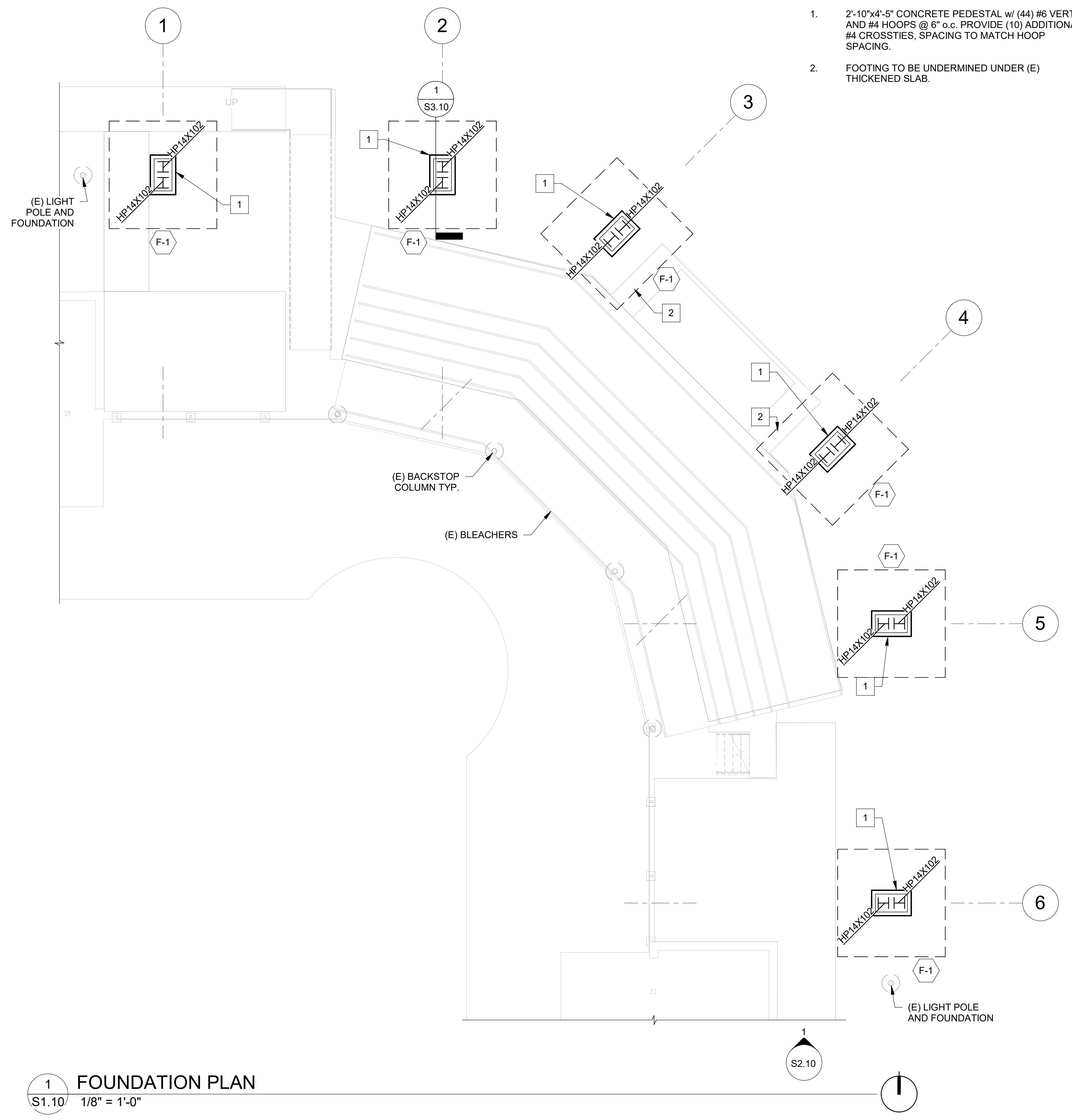

3/9/2026 3:15:50 PM
ONE INCH EQUALS FULL SCALE

1 FOUNDATION PLAN
S1.10 1/8" = 1'-0"

2 ROOF FRAMING PLAN
S1.10 1/8" = 1'-0"



DATE	Description

PROJECT NO. K-6428-25
DESIGNED: DKS
REVIEWED: KDM
DATE: 03-11-2026

**FOUNDATION AND
ROOF FRAMING
PLAN**

S1.10

BID & PERMIT SET | NOT ISSUED FOR CONSTRUCTION

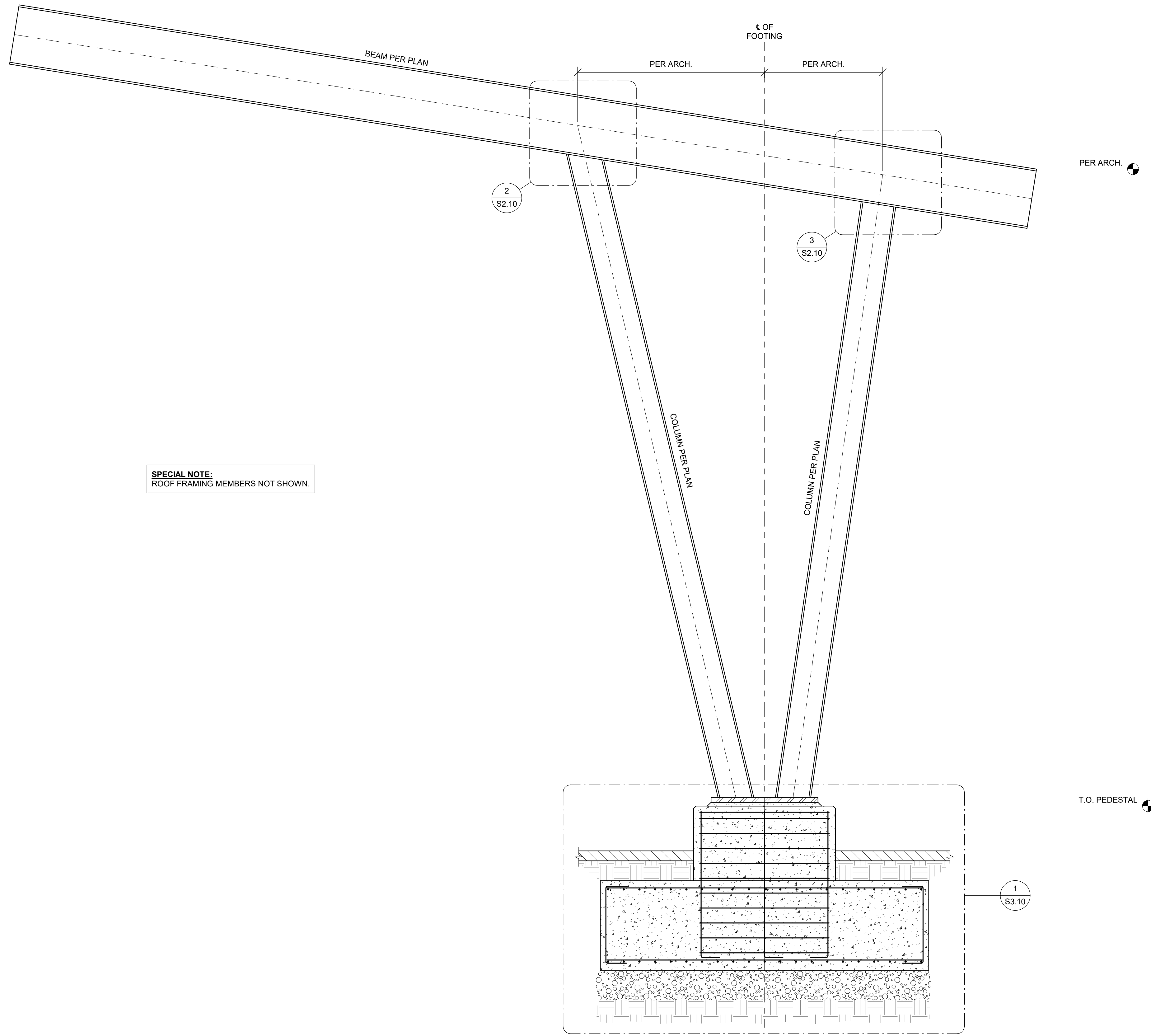

SPECIAL NOTE:
 ROOF FRAMING MEMBERS NOT SHOWN.

1
S2.10 TYP. FRAME ELEVATION
 1/2" = 1'-0"

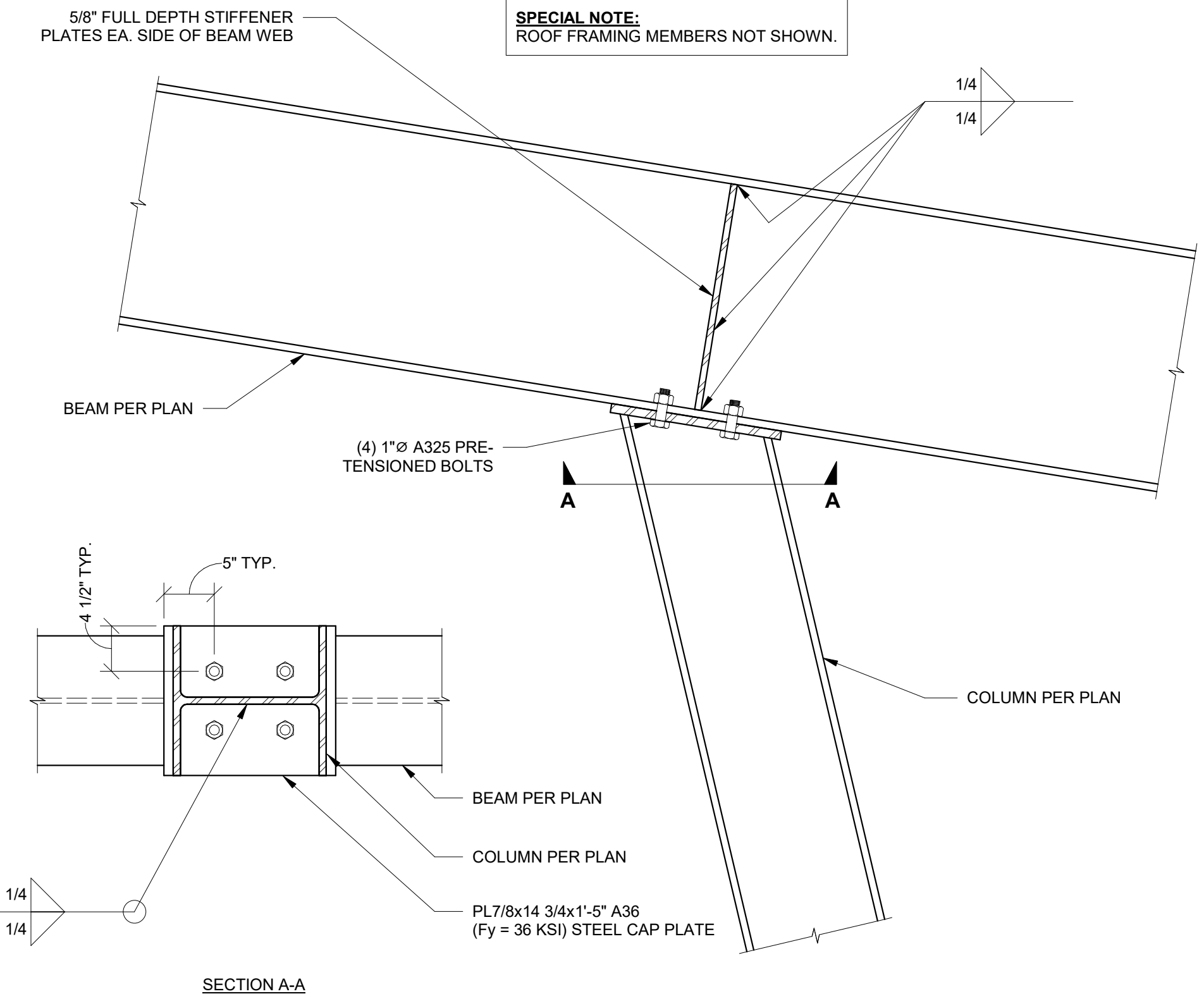

2
S2.10 FRONT COLUMN
 1" = 1'-0"

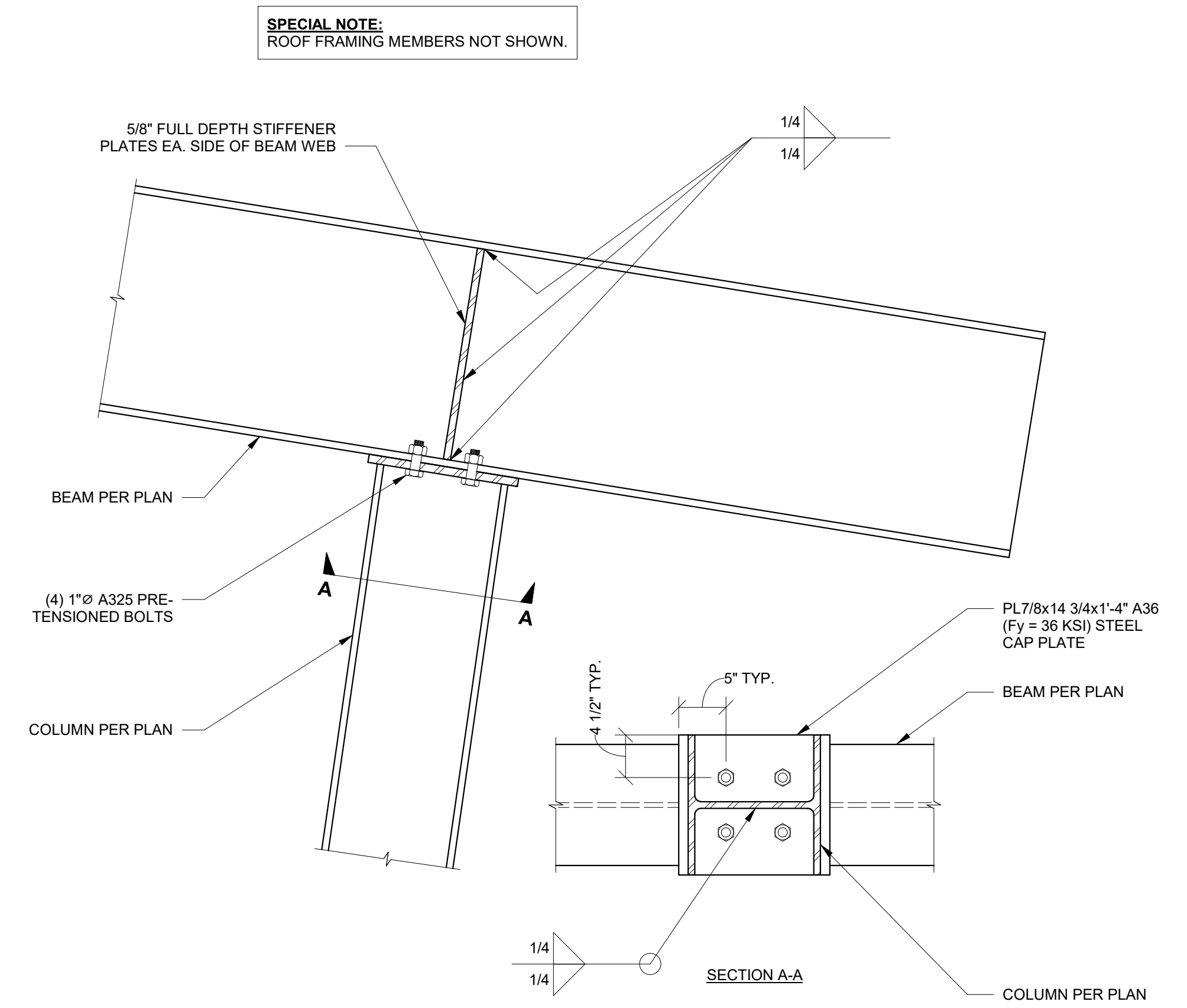

3
S2.10 BACK COLUMN
 1" = 1'-0"



DATE	Description

PROJECT NO. K-6428-25
 DESIGNED: DKS
 REVIEWED: KDM
 DATE: 03-11-2026

FRAME ELEVATION

S2.10

ONE INCH EQUALS FULL SCALE 3/9/2026 3:15:50 PM

BID & PERMIT SET | NOT ISSUED FOR CONSTRUCTION

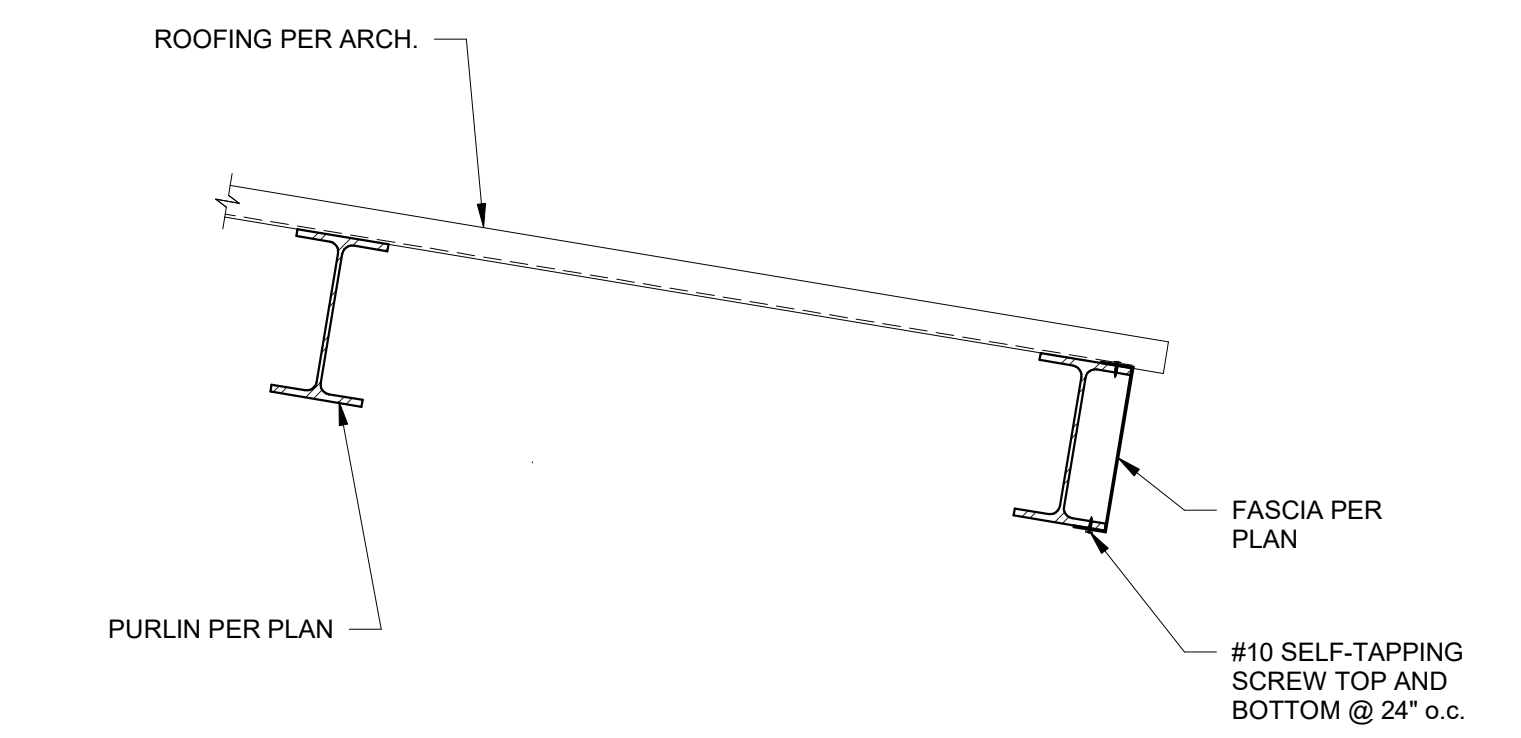
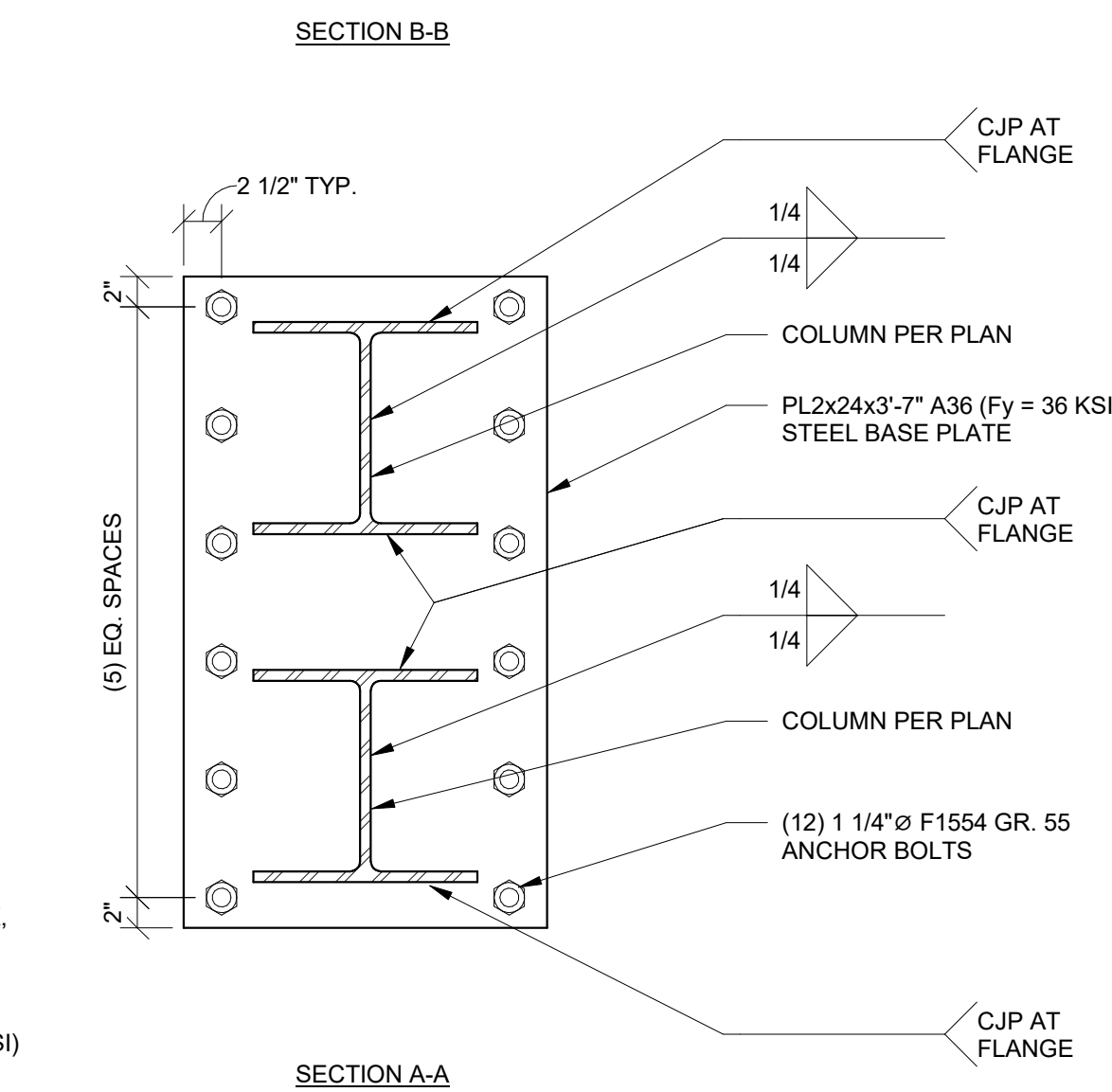
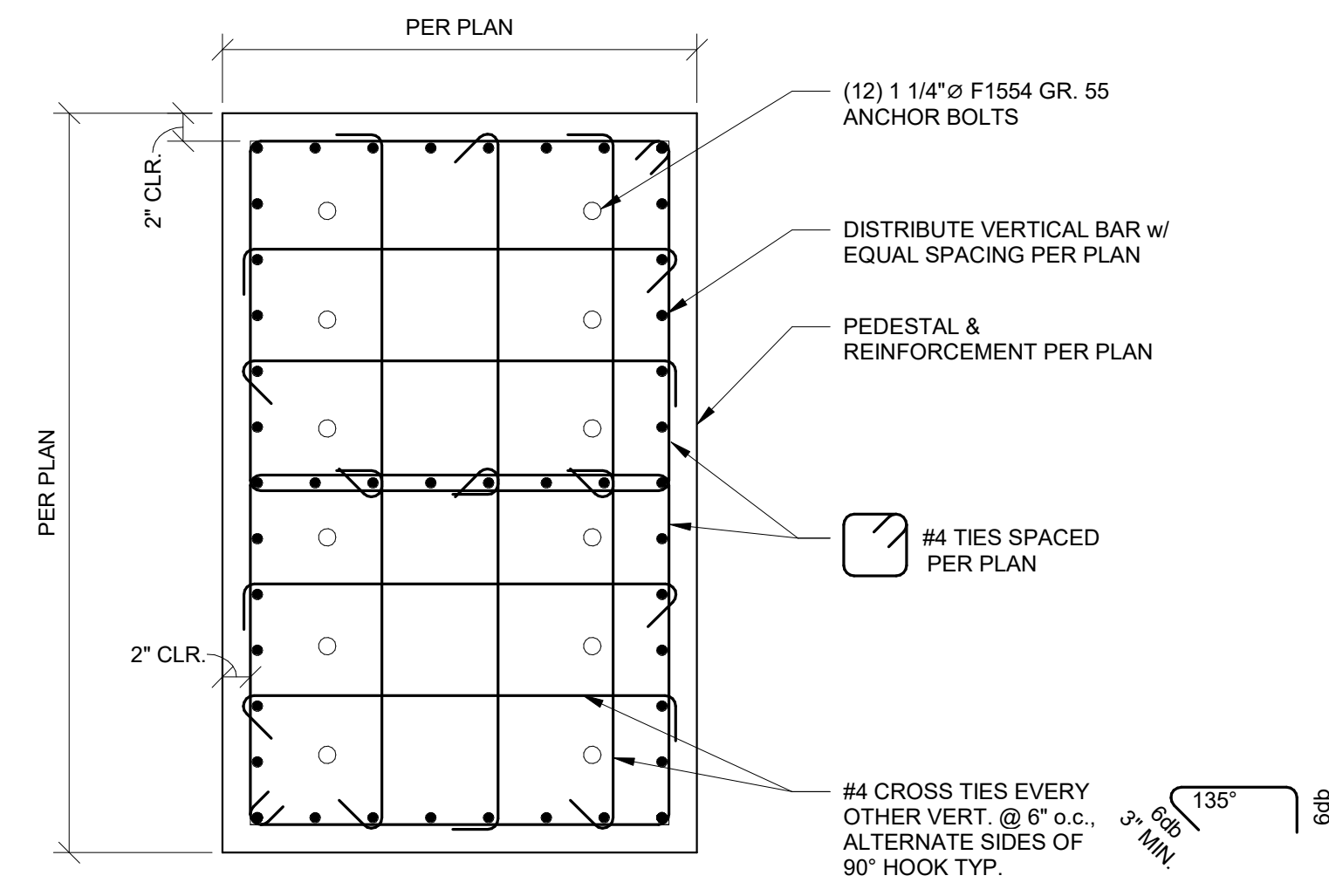
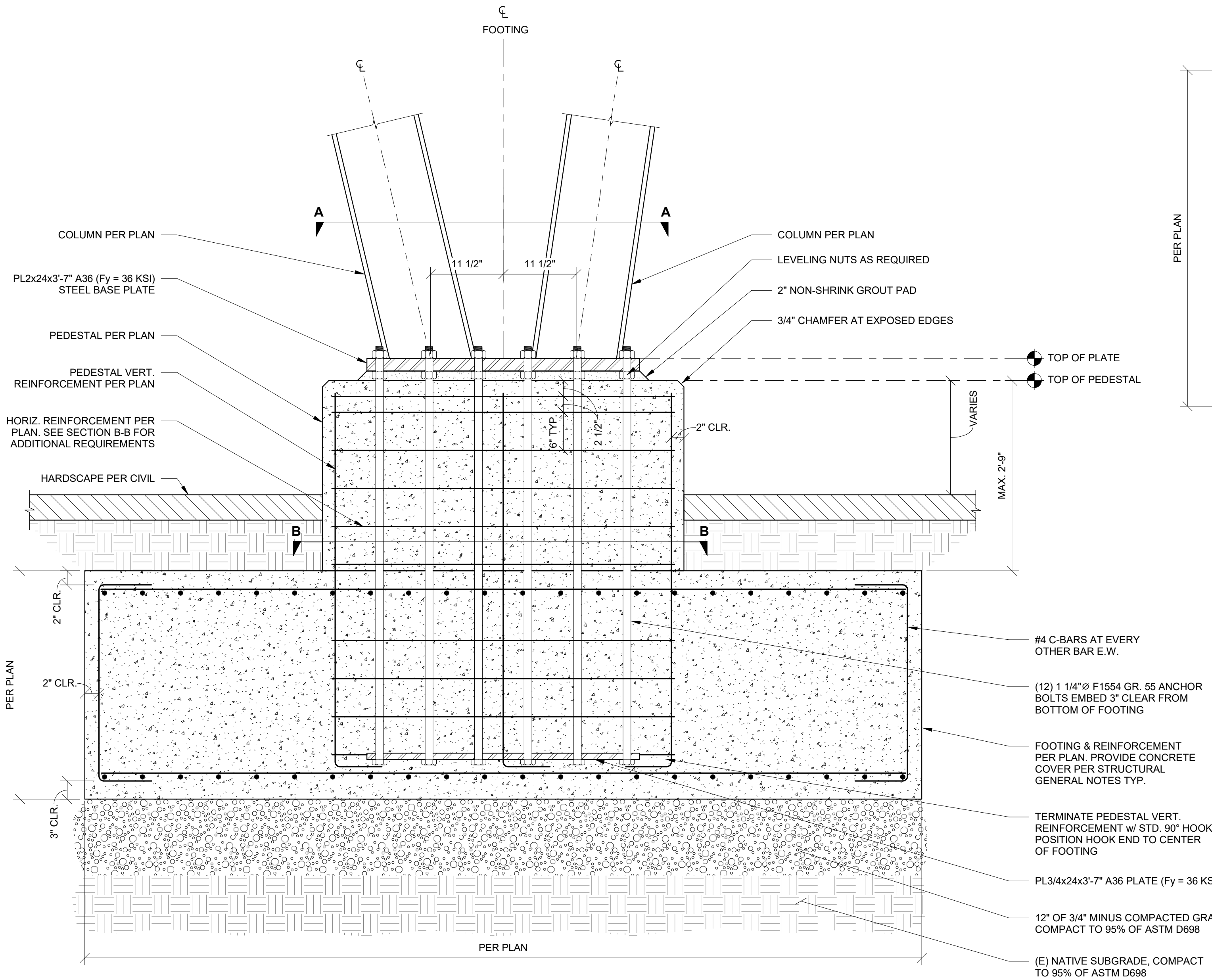

2 FRAMING AT LOW EAVE
S3.10 1" = 1'-0"

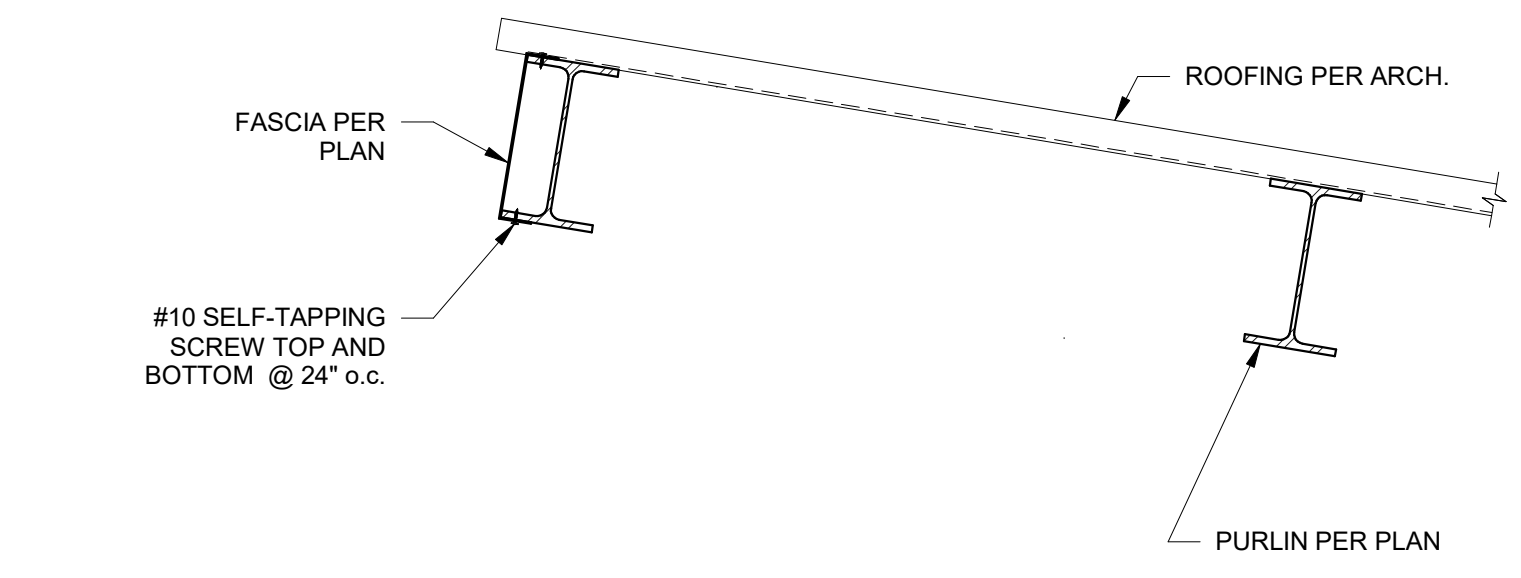

3 FRAMING AT HIGH EAVE
S3.10 1" = 1'-0"

1 TYP. SPREAD FOOTING DETAIL
S3.10 1" = 1'-0"

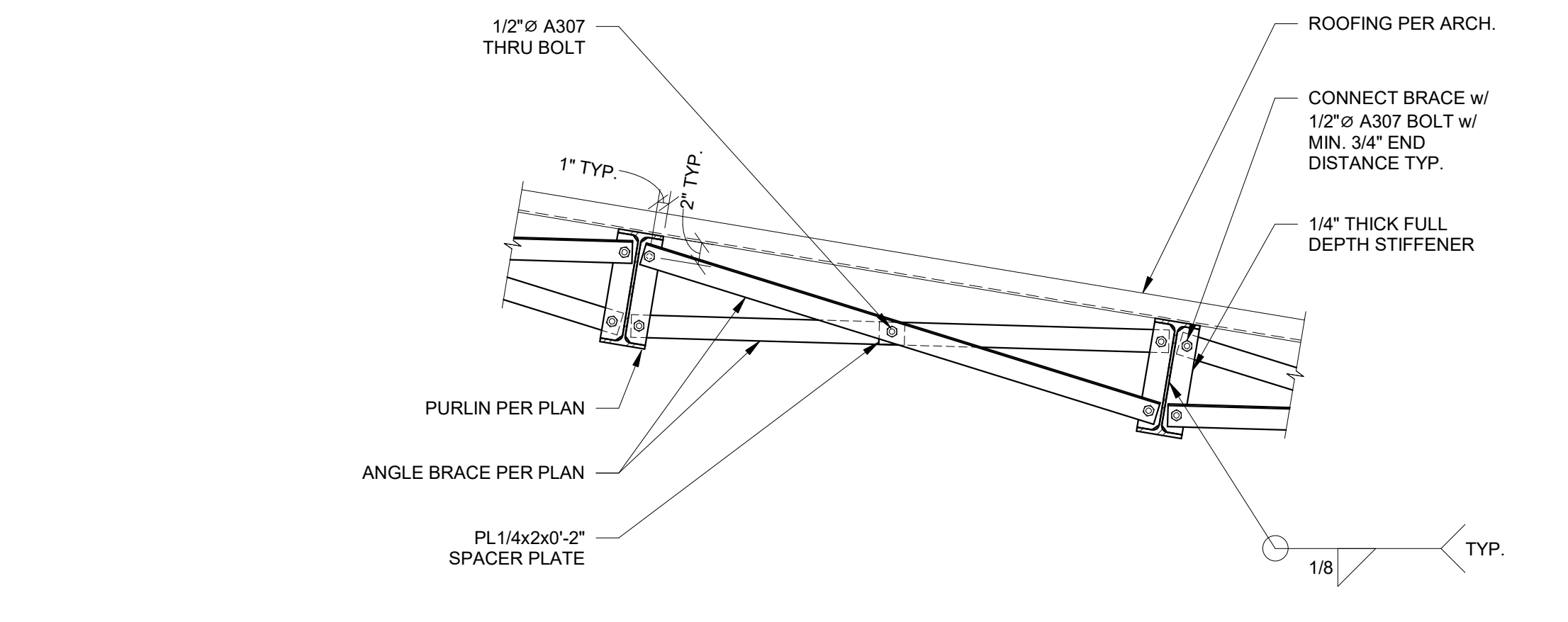
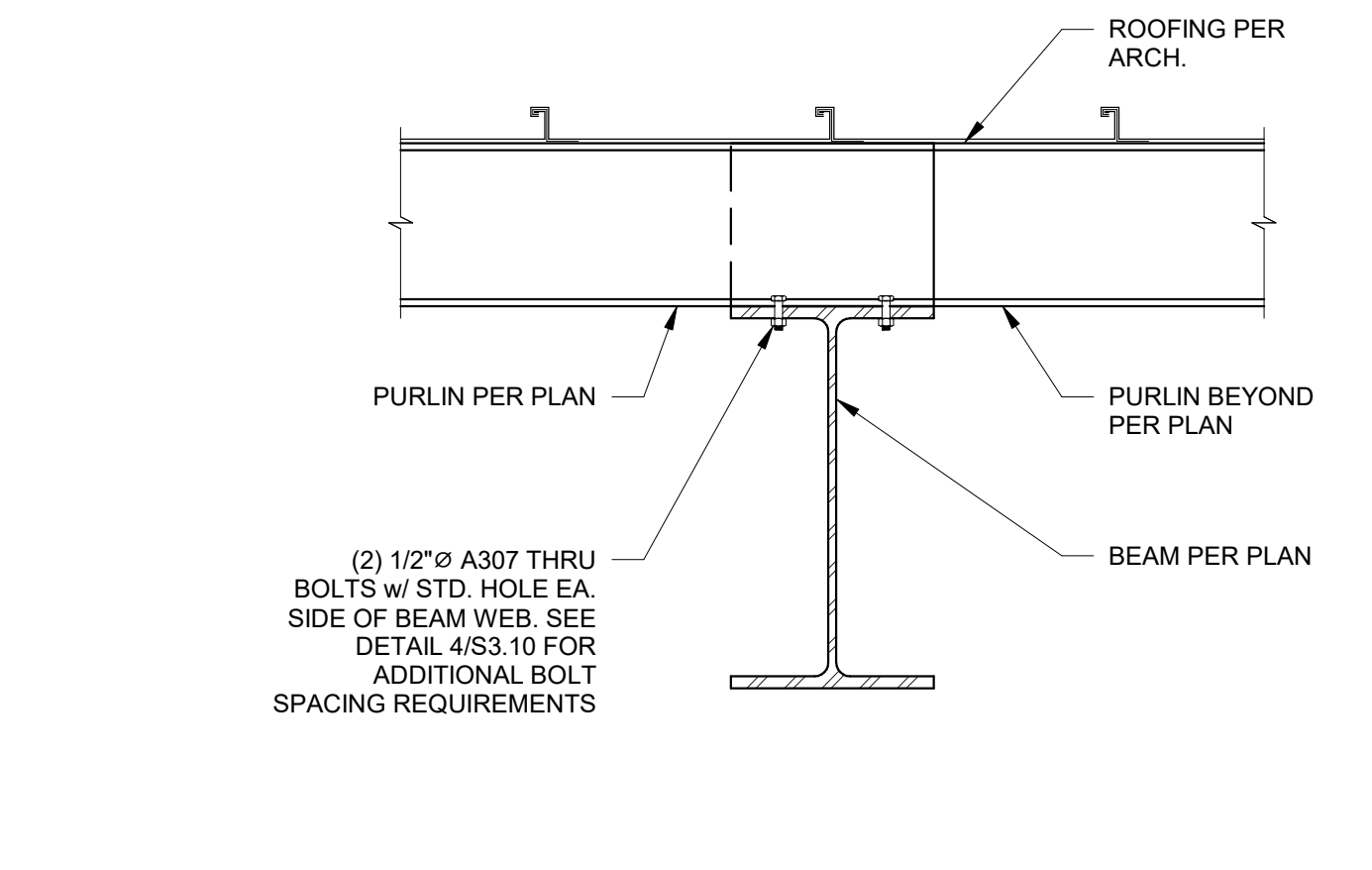
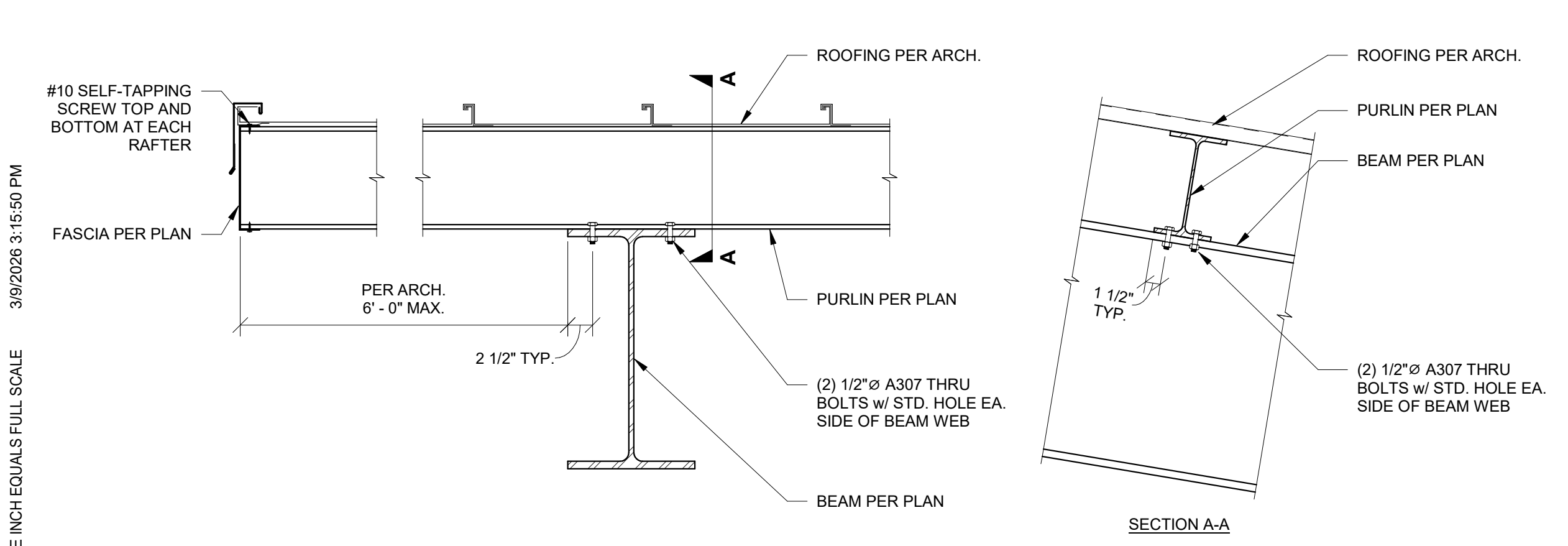

4 RAFTER PERPENDICULAR TO BEAM AT GL-1 & GL-6
S3.10 1" = 1'-0"

5 RAFTER PERPENDICULAR TO BEAM
S3.10 1" = 1'-0"

6 PURLIN BRACING
S3.10 1" = 1'-0"

ONE INCH EQUALS FULL SCALE

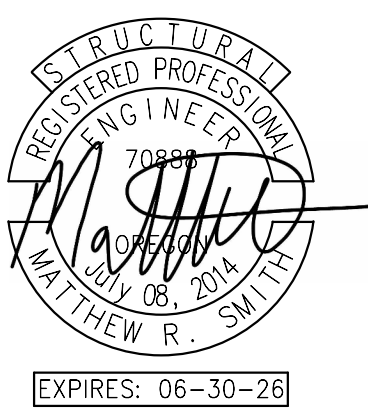

DATE	DESCRIPTION

PROJECT NO. K-6428-25
DESIGNED: DKS
REVIEWED: KDM
DATE: 03-11-2026

STRUCTURAL
DETAILS

S3.10

BID & PERMIT SET | NOT ISSUED FOR CONSTRUCTION

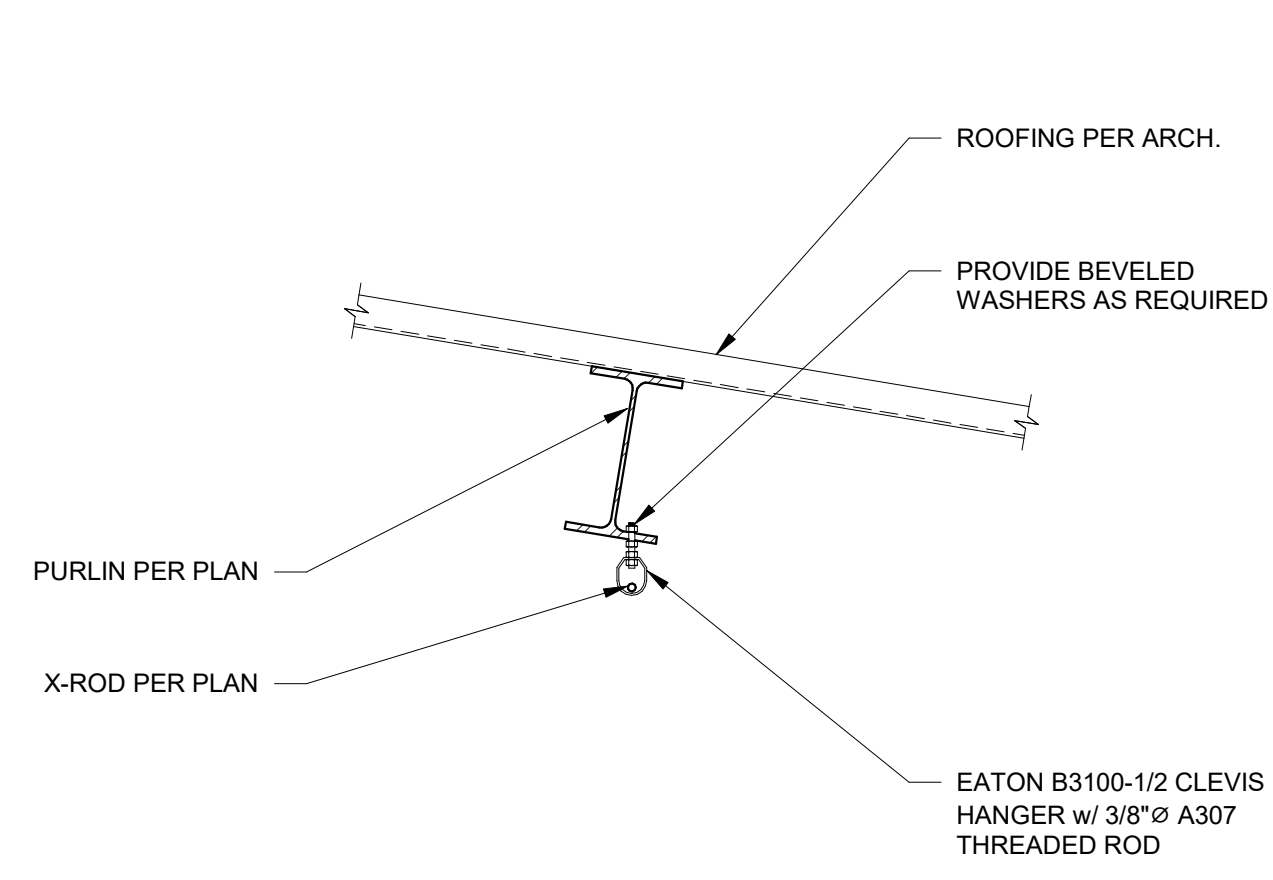

1 TYP. ROD SUPPORT
S3.20 1" = 1'-0"

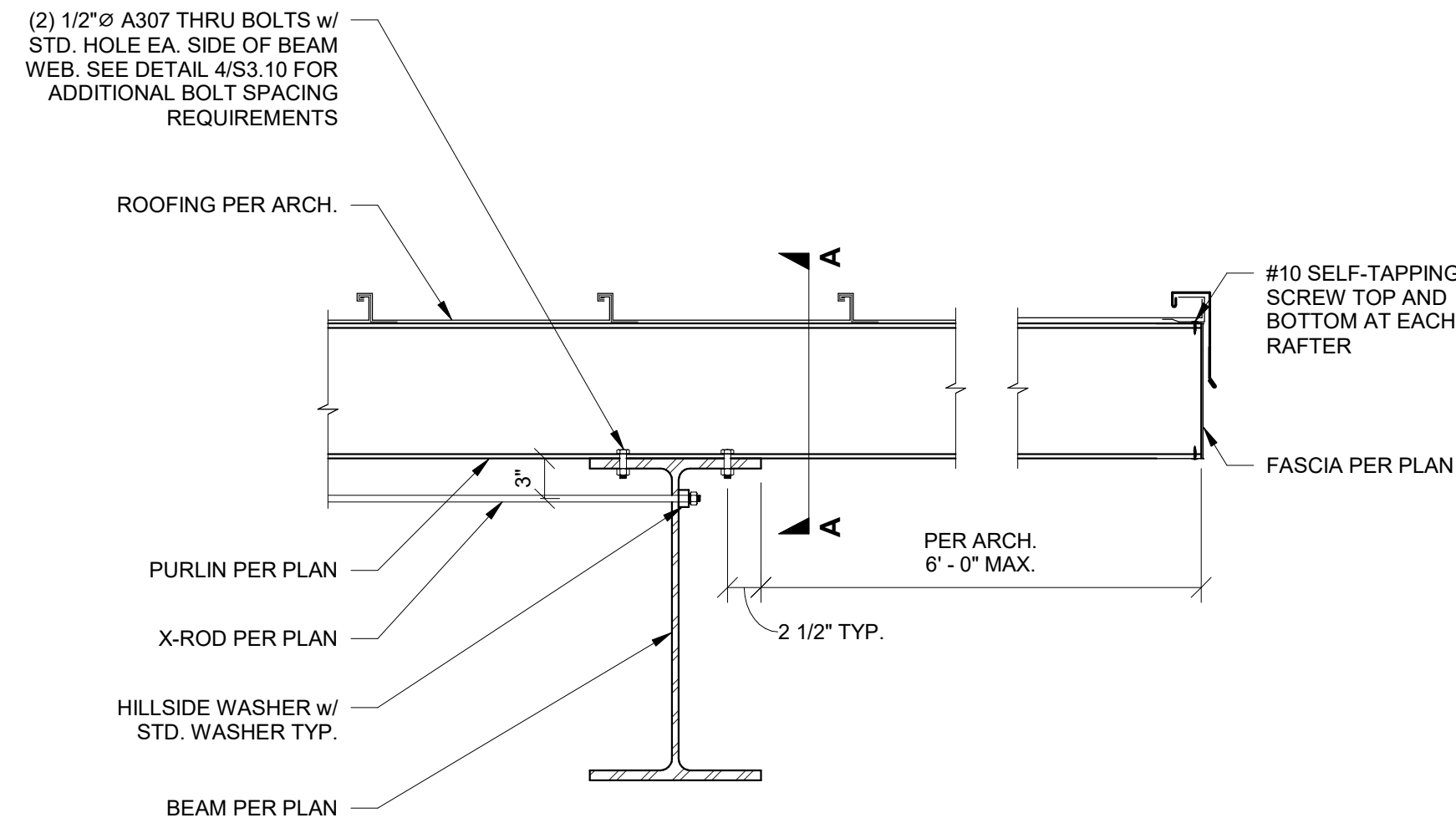

2 TYP. X-ROD CONNECTION
S3.20 1" = 1'-0"

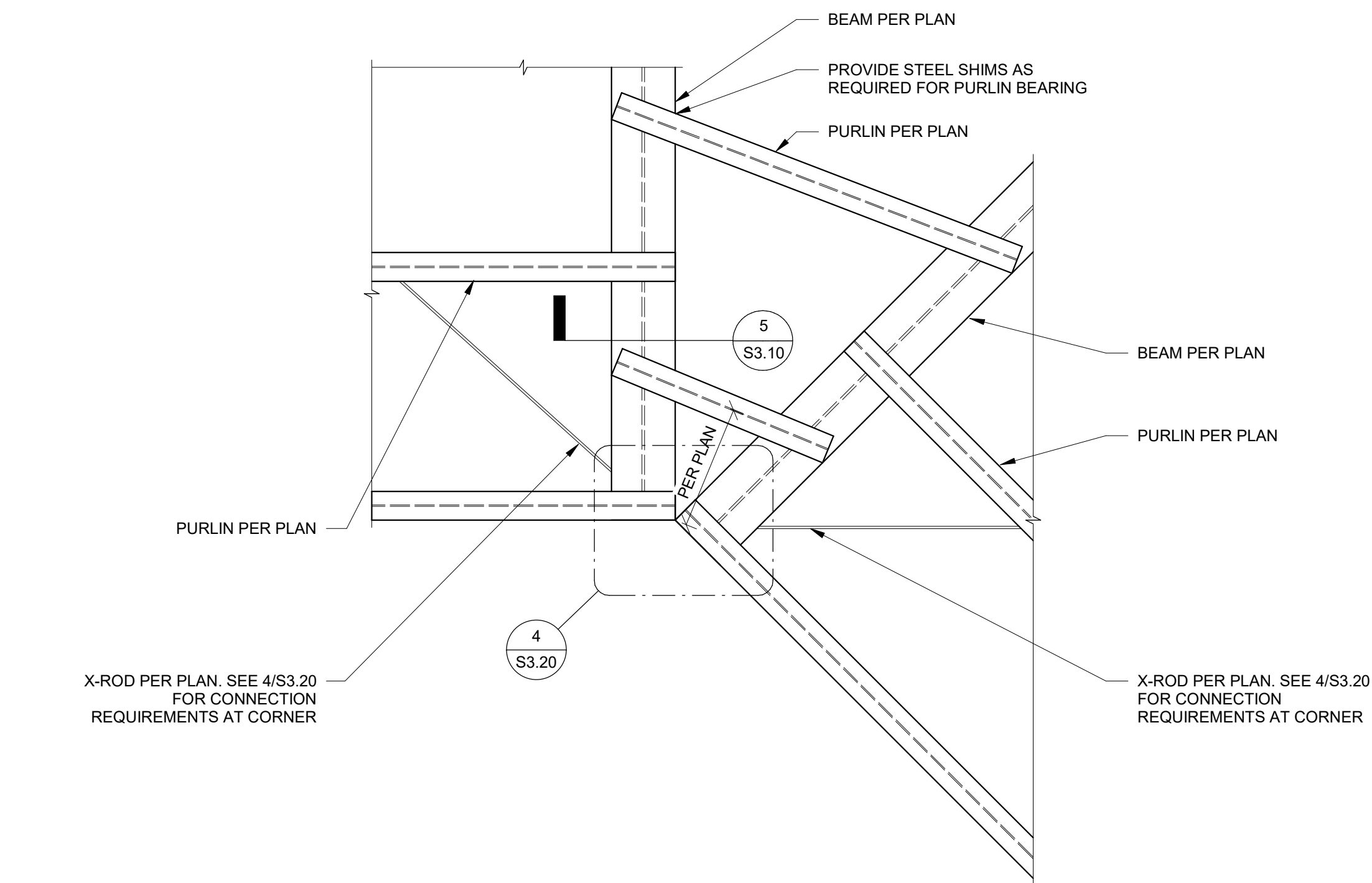
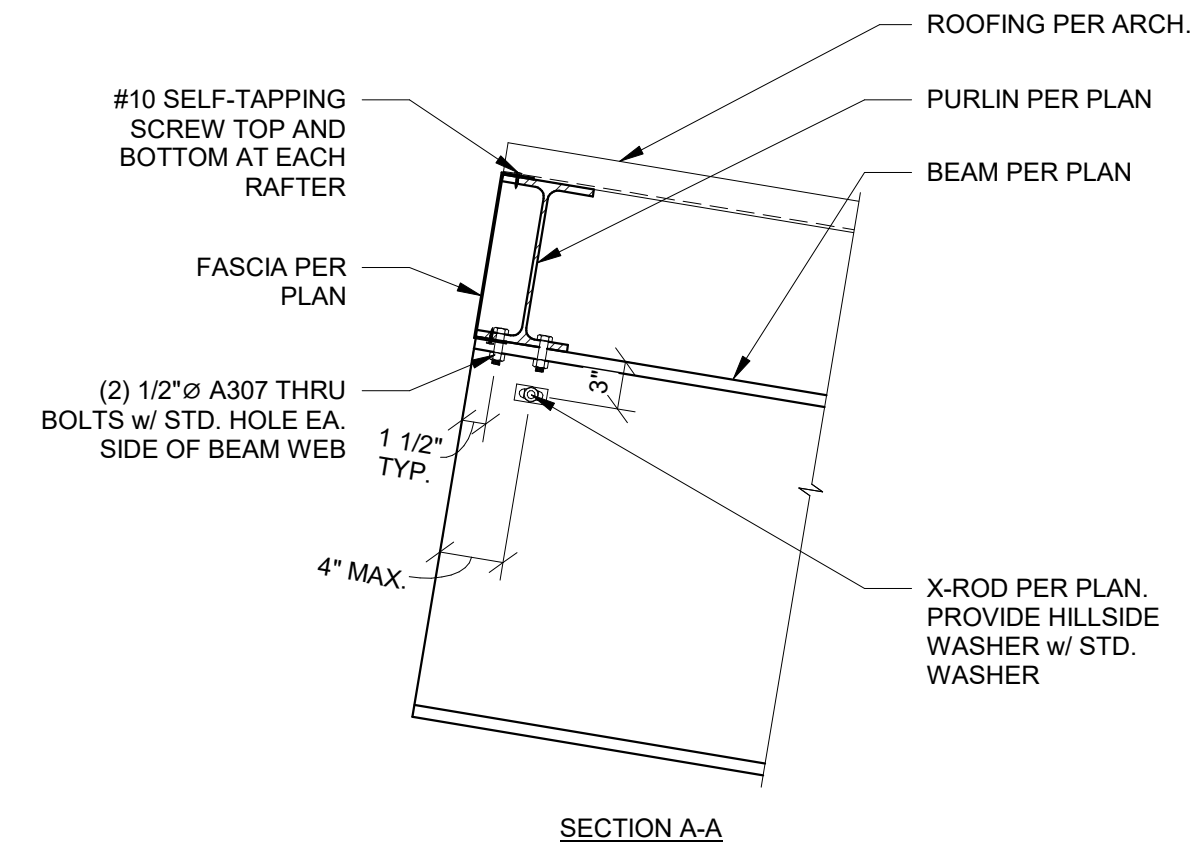

4 X-ROD CONNECTION AT INSIDE CORNER
S3.20 1" = 1'-0"

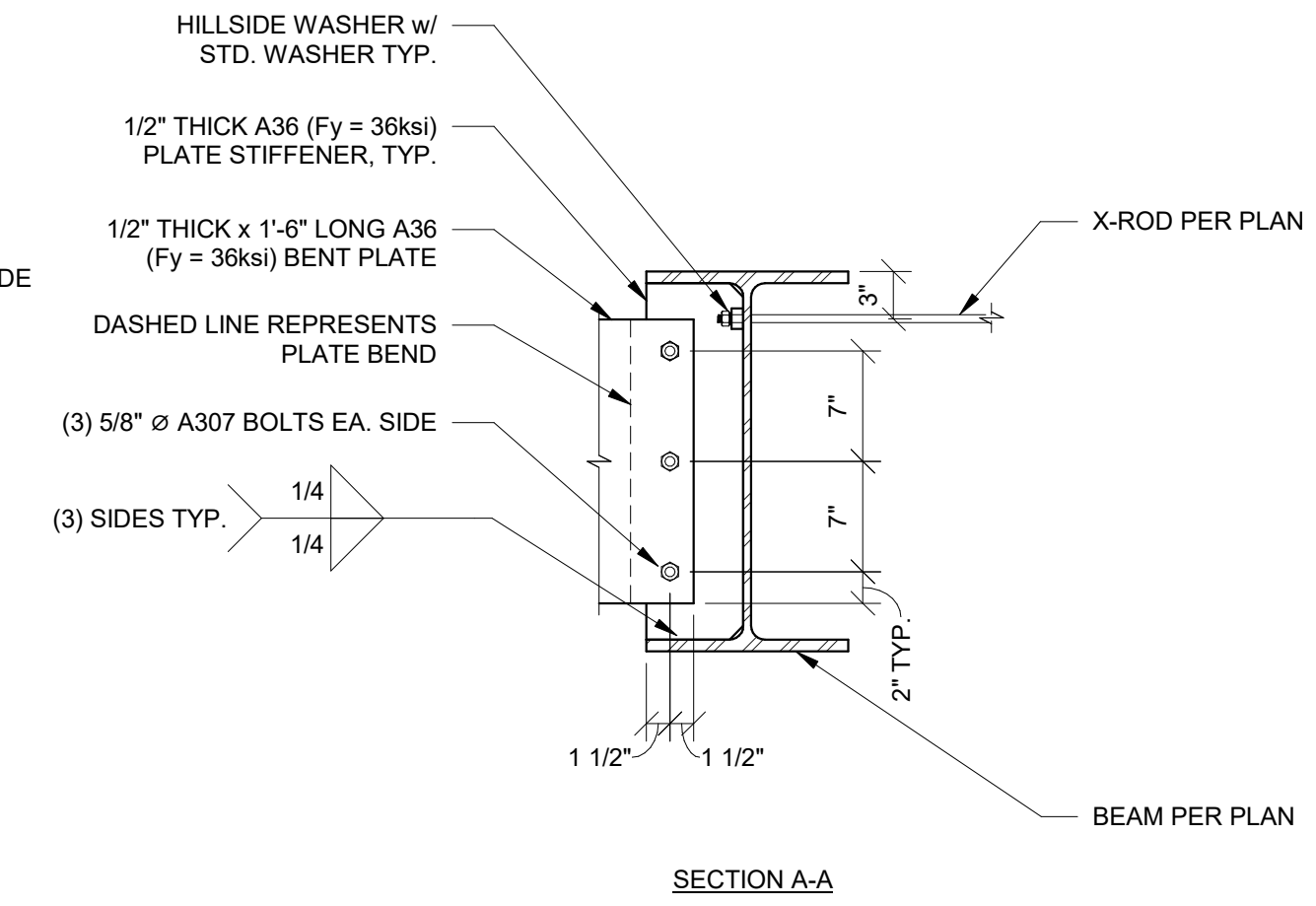

3 ENLARGED FRAMING VIEW AT INSIDE CORNER
S3.20 1/2" = 1'-0"

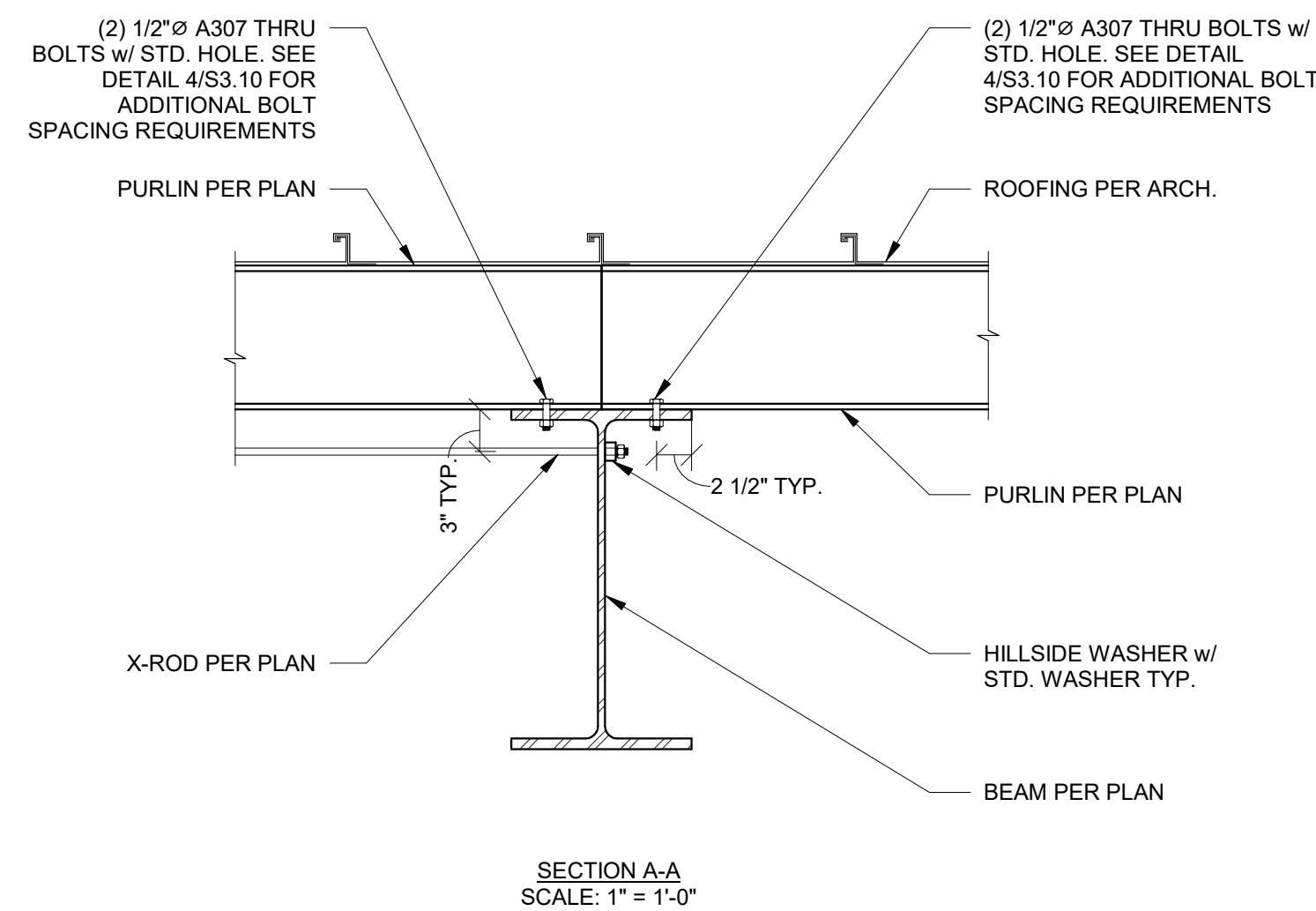

5 ENLARGED FRAMING VIEW AT OUTSIDE CORNER
S3.20 1/2" = 1'-0"

ONE INCH EQUALS FULL SCALE 3/9/2026 3:15:51 PM

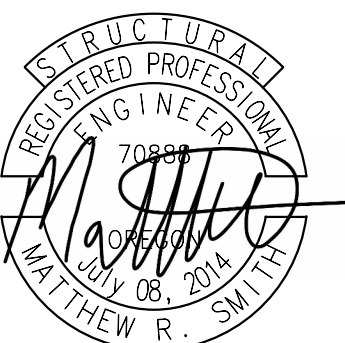

EXPIRES: 06-30-26

DATE	Description

PROJECT NO. K-6428-25
DESIGNED: DKS
REVIEWED: KDM
DATE: 03-11-2026

STRUCTURAL
DETAILS

S3.20

BID & PERMIT SET | NOT ISSUED FOR CONSTRUCTION